

# **Core Decodable Takehomes**

**Blackline Masters**

**Core Decodables 1–62**

**Grade 1**

**Book 1**



**MHEonline.com**



Copyright © 2015 McGraw-Hill Education

All rights reserved. The contents, or parts thereof, may be reproduced in print form for non-profit educational use with *SRA Open Court Reading*, provided such reproductions bear copyright notice, but may not be reproduced in any form for any other purpose without the prior written consent of McGraw-Hill Education, including, but not limited to, network storage or transmission, or broadcast for distance learning.

Send all inquiries to:  
McGraw-Hill Education  
8787 Orion Place  
Columbus, OH 43240

ISBN: 978-0-07-679897-1  
MHID: 0-07-679897-6

Printed in the United States of America.

2 3 4 5 6 7 8 9 QVS 20 19 18 17 16 15



# Contents

## Grade 1 Core Decodables 1–62

About the Decodable Takehomes.....	5–6
Parent Letter .....	7
High-Frequency Words and Sound/Spellings	
Correspondences.....	8
1 See! .....	9–12
2 Up .....	13–16
3 I Have .....	17–20
4 There Is .....	21–24
5 I Can See.....	25–28
6 Sam, Sam, Sam .....	29–32
7 Matt and Sam.....	33–36
8 On a Mat .....	37–44
9 Dad Sat.....	45–48
10 Ants .....	49–52
11 Sit.....	53–56
12 A Hint .....	57–60
13 Mints.....	61–68
14 Pat’s Map .....	69–72
15 Lin and Hal.....	73–76
16 A Spot.....	77–80
17 Bob at Bat.....	81–84
18 Bill.....	85–92
19 Nap’s Cap .....	93–96
20 At the Mall .....	97–100
21 Picnic.....	101–104
22 Rick and Rob.....	105–108
23 Cal and Kip.....	109–116
24 Bobcat .....	117–120
25 Pat’s Class Trip .....	121–124
26 Rag Bits.....	125–128
27 A Jog in Fog .....	129–132
28 A Cap Fan.....	133–140
29 Jack’s Job.....	141–144
30 Plum Pond .....	145–148

31	Buzz and Zip.....	149–152
32	Hills of Fuzz .....	153–156
33	Rock and Jazz .....	157–164
34	Max and Sam .....	165–168
35	A Red Fox.....	169–172
36	The Glass .....	173–176
37	Best Mom.....	177–180
38	Fix a Truck.....	181–188
39	Ted’s List .....	189–192
40	Trish’s Ship .....	193–196
41	Beth Gets a Snack.....	197–200
42	Mitch on a Ranch .....	201–204
43	Ball Camp.....	205–212
44	At a Port .....	213–216
45	In a Jar .....	217–220
46	Wes Gets Wet.....	221–224
47	The Whiz .....	225–228
48	A Spark in the Dark .....	229–232
49	Bird Shirts .....	233–236
50	A Blur with Fur.....	237–240
51	Earnest’s Search .....	241–244
52	Big Bing .....	245–248
53	Purple.....	249–252
54	The Children Get a Rabbit.....	253–256
55	Pump and Pedal.....	257–260
56	In the Tank .....	261–264
57	Quick Quin .....	265–268
58	King Frank .....	269–276
59	Beth’s Yak .....	277–280
60	Seven Pals .....	281–284
61	April’s Bake Shop .....	285–288
62	Tab.....	289–296

# About the Decodable Takehomes

The *SRA Open Court Reading Decodable Takehomes* allow your students to apply their knowledge of phonic elements to read simple, engaging texts. Each story supports instruction in a new phonic element and incorporates elements and words that have been learned earlier.

The students can fold and staple the pages of each *Decodable Takehome* to make books of their own to keep and read. We suggest that you keep extra sets of the stories in your classroom for the students to reread.

## How to Make a Takehome

1. Tear out the pages you need.

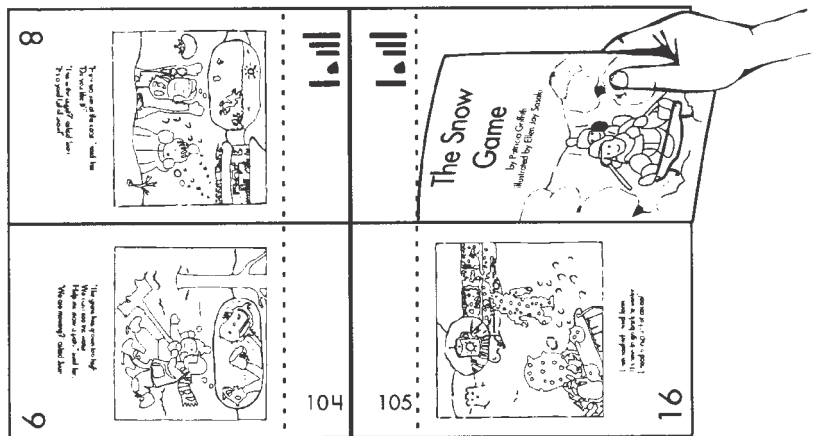

2. Place pages 4 and 5, and pages 2 and 7 faceup for 8-page books.

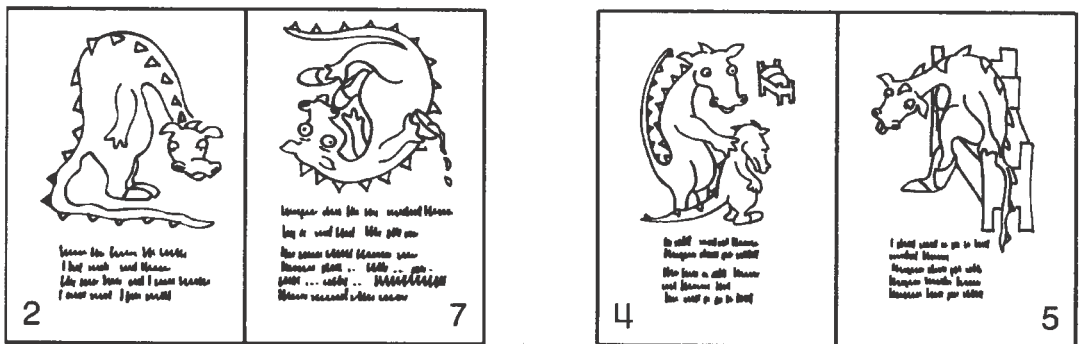

## For 16-page book

- Place the pages on top of each other in this order: pages 8 and 9, pages 6 and 11, pages 4 and 13, and pages 2 and 15.

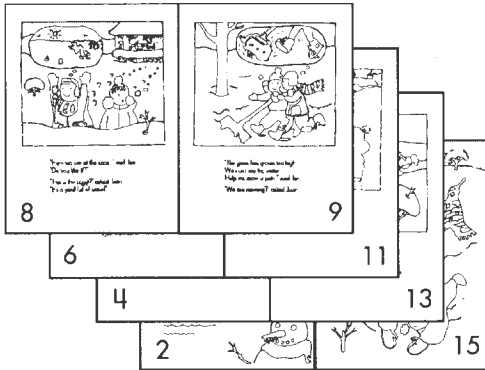

- Fold along the center line.

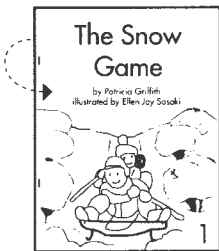

- Check to make sure the pages are in order.

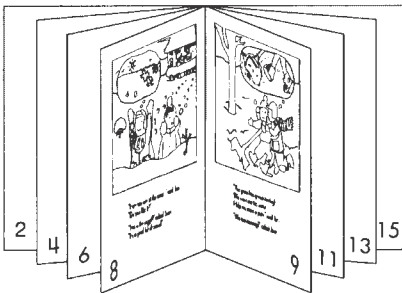

- Staple the pages along the fold.

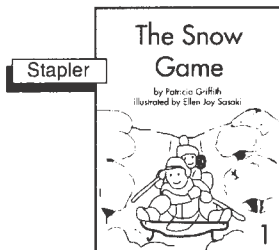

## For 8-page book

- Place pages 4 and 5 on top of pages 2 and 7.

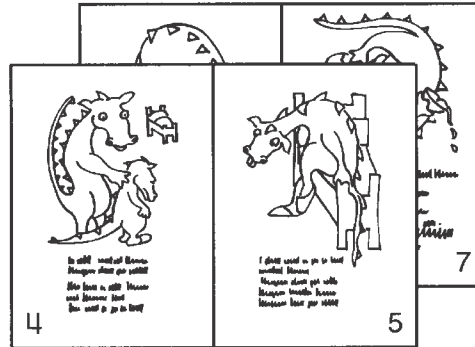

- Fold along the center line.

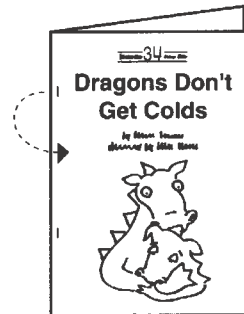

- Check to make sure the pages are in order.



- Staple the pages along the fold.

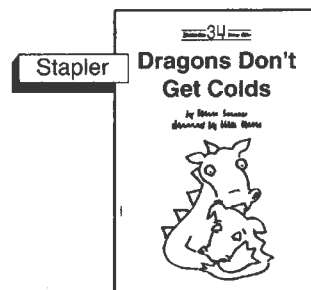

## *Just to let you know...*

A message from \_\_\_\_\_

Help your child discover the joy of independent reading with ***SRA Open Court Reading***. From time to time your child will bring home his or her very own *Pre-Decodable* or *Decodable Takehomes* to share with you. With your help, these stories can give your child important reading practice and a joyful shared reading experience.

You may want to set aside a few minutes every evening to read these stories together. Here are some suggestions you may find helpful:

- Do not expect your child to read each story perfectly, but concentrate on sharing the book together.
- Participate by doing some of the reading.
- Talk about the stories you read, give lots of encouragement, and watch as your child becomes more fluent throughout the year!

Learning to read takes lots of practice. Sharing these stories is one way that your child can gain that valuable practice. Encourage your child to keep the *Pre-Decodable* or *Decodable Takehomes* in a special place. This collection will make a library of books that your child can read and reread. Take the time to listen to your child read from his or her library. Just a few moments of shared reading each day can give your child the confidence needed to excel in reading.

Children who read every day come to think of reading as a pleasant, natural part of life. One way to inspire your child to read is to show that reading is an important part of your life by letting him or her see you reading books, magazines, newspapers, or any other materials. Another good way to show that you value reading is to share a *Pre-Decodable* or *Decodable Takehome* with your child each day.

Successful reading experiences allow children to be proud of their newfound reading ability. Support your child with interest and enthusiasm about reading. You won't regret it!

## High-Frequency Words

a	boy	from	I	now	sleep	was
about	brown	get	if	of	some	water
after	but	girl	in	old	take	way
all	by	go	into	on	that	we
am	call	going	is	one	the	well
an	came	good	it	or	their	went
and	can	got	its	out	them	were
any	come	green	jump	over	then	what
are	could	had	just	pretty	there	when
around	day	has	know	put	they	where
as	did	have	like	red	this	will
ask	do	he	little	ride	to	with
at	don't	help	long	right	too	would
away	down	her	look	said	two	yellow
be	every	here	make	saw	up	yes
before	five	him	me	see	very	you
big	for	his	my	she	walk	your
blue	four	how	no	six	want	

## Sound/Spelling Correspondences in Core Decodables

- |   |                                  |                                  |   |
|---|----------------------------------|----------------------------------|---|
| 1. Pre-decodable  | 31. /z/ spelled <i>z, zz</i>     | 64. /s/ spelled <i>ce, ci_</i>   | 97. /ow/ spelled <i>ou_</i>                   |
| 2. Pre-decodable  | 32. /z/ spelled <i>_s</i>        | 65. /j/ spelled <i>ge, gi_</i>   | 98. /aw/ spelled <i>au_, aw</i>               |
| 3. Pre-decodable  | 33. Review                       | 66. Review                       | 99. Review                                    |
| 4. Pre-decodable  | 34. /ks/ spelled <i>■x</i>       | 67. /ō/ spelled <i>o, o_e</i>    | 100. /aw/ spelled <i>augh,</i><br><i>ough</i> |
| 5. Pre-decodable  | 35. /e/ spelled <i>e</i>         | 68. /ū/ spelled <i>u, u_e</i>    | 101. /oi/ spelled <i>oi, _oy</i>              |
| 6. /s/ spelled <i>s,</i><br>/m/ spelled <i>m,</i><br>/a/ spelled <i>a</i> | 36. <i>-ed</i> ending: /ed/, /d/ | 69. Review                       | 102. Review                                   |
| 7. /t/ spelled <i>t, tt</i>   | 37. <i>-ed</i> ending: /t/       | 70. /ē/ spelled <i>e, e_e</i>    | 103. Prefixes <i>un-, dis-</i>                |
| 8. Review   | 38. Review                       | 71. /ē/ spelled <i>ee, ea</i>    | 104. Prefixes <i>im-, in-, re-</i>            |
| 9. /d/ spelled <i>d</i>   | 39. /e/ spelled <i>_ea_</i>      | 72. Review /ē/                   | 105. Review /ā/ and /a/                       |
| 10. /n/ spelled <i>n</i>  | 40. /sh/ spelled <i>sh</i>       | 73. /ē/ spelled <i>_y, _ie_</i>  | 106. Review /ī/ and /i/                       |
| 11. /i/ spelled <i>i</i>  | 41. /th/ spelled <i>th</i>       | 74. /ē/ spelled <i>_ey</i>       | 107. Review /ō/ and /o/                       |
| 12. /h/ spelled <i>h_</i>   | 42. /ch/ spelled <i>ch, ■tch</i> | 75. Review                       | 108. Review /ū/ and /u/                       |
| 13. Review  | 43. Review                       | 76. /s/ spelled <i>cy</i>        | 109. Review /ē/ and /e/                       |
| 14. /p/ spelled <i>p</i>  | 44. /or/ spelled <i>or, ore</i>  | 77. /ā/ spelled <i>ai_, _ay</i>  | 110. Review consonant<br>digraphs             |
| 15. /l/ spelled <i>l, ll</i>  | 45. /ar/ spelled <i>ar</i>       | 78. Review                       | 111. Review r-controlled<br>vowels            |
| 16. /o/ spelled <i>o</i>  | 46. /w/ spelled <i>w_</i>        | 79. /i/ spelled <i>_igh</i>      | 112. Review /oo/ and /ōō/                     |
| 17. /b/ spelled <i>b</i>  | 47. /w/ spelled <i>wh_</i>       | 80. /i/ spelled <i>_y, _ie</i>   | 113. Review diphthongs                        |
| 18. Review  | 48. Review                       | 81. Review /i/                   | 114. Review inflectional<br>endings           |
| 19. /k/ spelled <i>c</i>  | 49. /er/ spelled <i>er, ir</i>   | 82. /ō/ spelled <i>oa_, _ow</i>  |   |
| 20. special spelling <i>al,</i><br><i>all</i>                             | 50. /er/ spelled <i>ur</i>       | 83. /ū/ spelled <i>_ew, _ue</i>  |   |
| 21. /k/ spelled <i>k, ■ck</i>   | 51. /er/ spelled <i>ear</i>      | 84. Review                       |   |
| 22. /r/ spelled <i>r</i>  | 52. /ng/ spelled <i>■ng</i>      | 85. /m/ spelled <i>_mb</i>       |   |
| 23. Review  | 53. Review                       | 86. /n/ spelled <i>kn_, gn</i>   |   |
| 24. /f/ spelled <i>f, ff</i>  | 54. Schwa                        | 87. /r/ spelled <i>wr_</i>       |   |
| 25. /s/ spelled <i>ss</i>   | 55. <i>-e, -el, -il, -al</i>     | 88. /f/ spelled <i>ph</i>        |   |
| 26. /g/ spelled <i>g</i>  | 56. /nk/ spelled <i>■nk</i>      | 89. Review                       |   |
| 27. /j/ spelled <i>j</i>  | 57. /kw/ spelled <i>qu_</i>      | 90. /ōō/ spelled <i>oo</i>       |   |
| 28. Review  | 58. Review                       | 91. /ōō/ spelled <i>u, _ue</i>   |   |
| 29. /j/ spelled <i>■dge</i>   | 59. /y/ spelled <i>y_</i>        | 92. Review                       |   |
| 30. /u/ spelled <i>u</i>  | 60. /v/ spelled <i>v</i>         | 93. /ōō/ spelled <i>_ew, u_e</i> |   |
|   | 61. /ā/ spelled <i>a, a_e</i>    | 94. /oo/ spelled <i>oo</i>       |   |
|   | 62. Review                       | 95. Review                       |   |
|   | 63. /i/ spelled <i>i, i_e</i>    | 96. /ow/ spelled <i>ow</i>       |   |

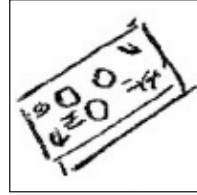

money

See the !

# See!

by Cameron Grieff  
illustrated by Anni Matsick

Core Decodable I



Bothell, WA • Chicago, IL • Columbus, OH • New York, NY

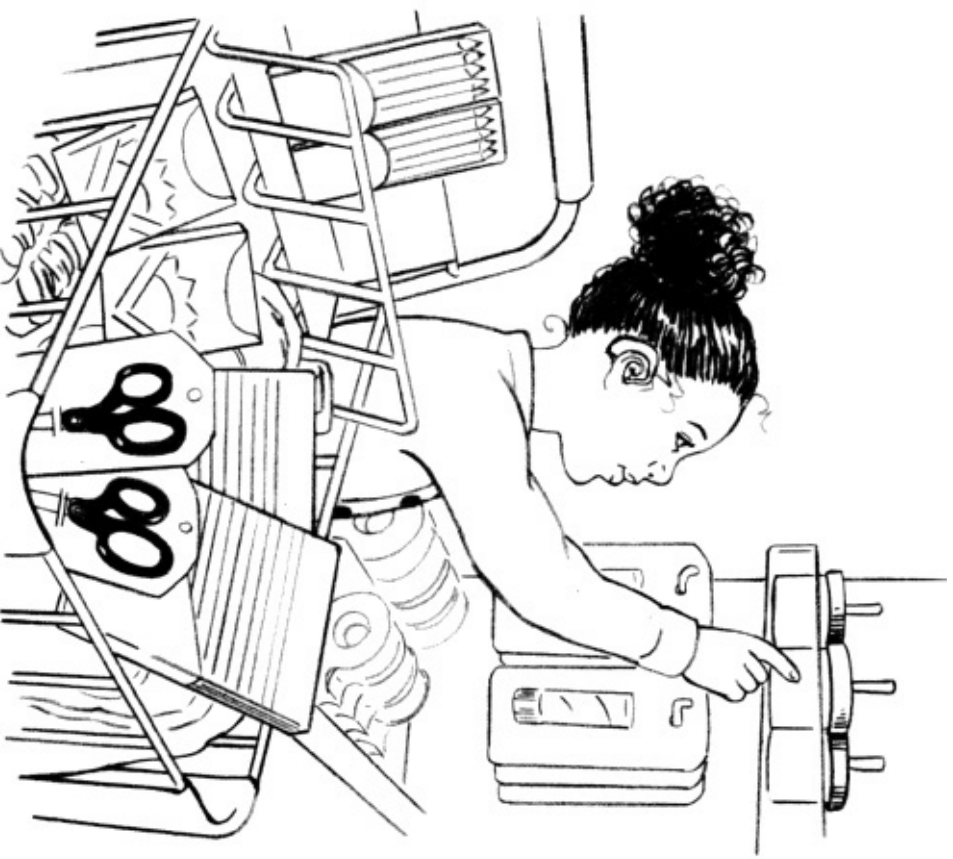

See the

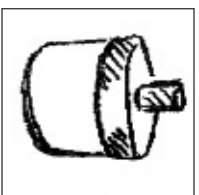

paste

MHEonline.com



Copyright © 2015 McGraw-Hill Education

All rights reserved. The contents, or parts thereof, may be reproduced in print form for non-profit educational use with *SRA Open Court Reading*, provided such reproductions bear copyright notice, but may not be reproduced in any form for any other purpose without the prior written consent of McGraw-Hill Education, including, but not limited to, network storage or transmission, or broadcast for distance learning.

Send all inquiries to:  
 McGraw-Hill Education  
 8787 Orion Place  
 Columbus, OH 43240



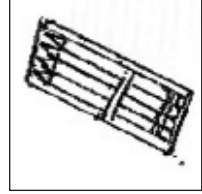

pencils

See the

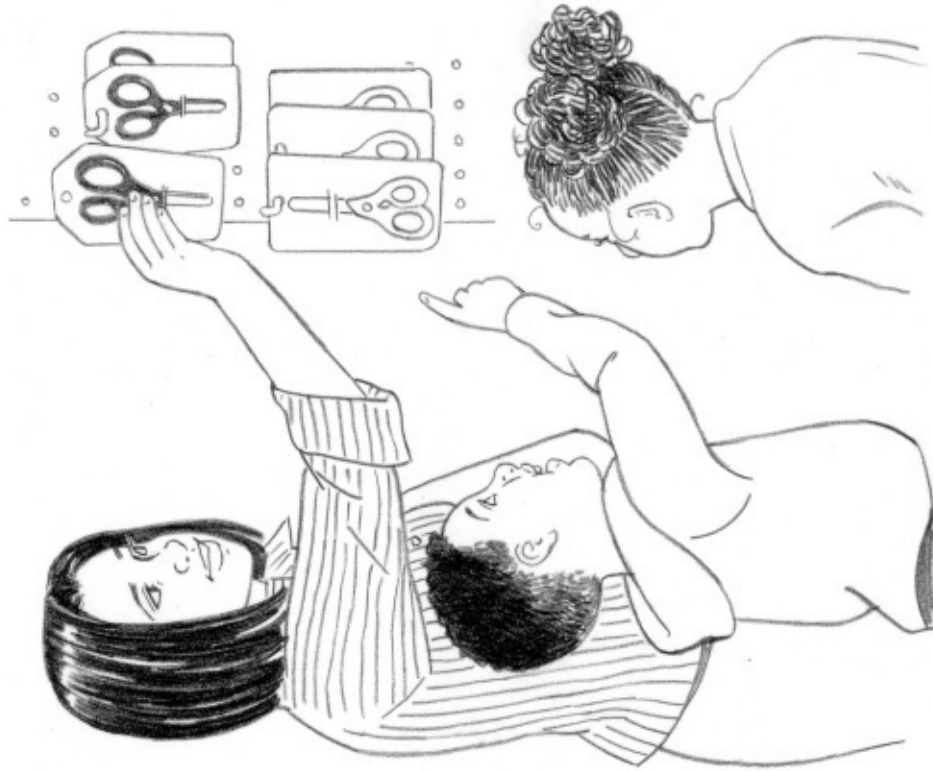

scissors

See the



See the

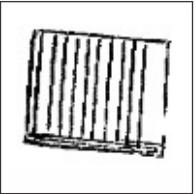

paper

4



See the

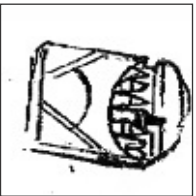

crayons

5

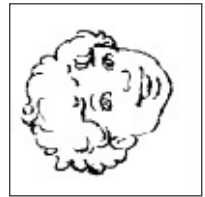

is up!

boy

The

# Up

by Tameron Dennis  
illustrated by Eva Vagreti

Core Decodable 2



Bothell, WA • Chicago, IL • Columbus, OH • New York, NY



See the

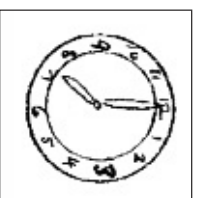

i

clock

MHEonline.com



Copyright © 2015 McGraw-Hill Education

All rights reserved. The contents, or parts thereof, may be reproduced in print form for non-profit educational use with *SRA Open Court Reading*, provided such reproductions bear copyright notice, but may not be reproduced in any form for any other purpose without the prior written consent of McGraw-Hill Education, including, but not limited to, network storage or transmission, or broadcast for distance learning.

Send all inquiries to:  
McGraw-Hill Education  
8787 Orion Place  
Columbus, OH 43240



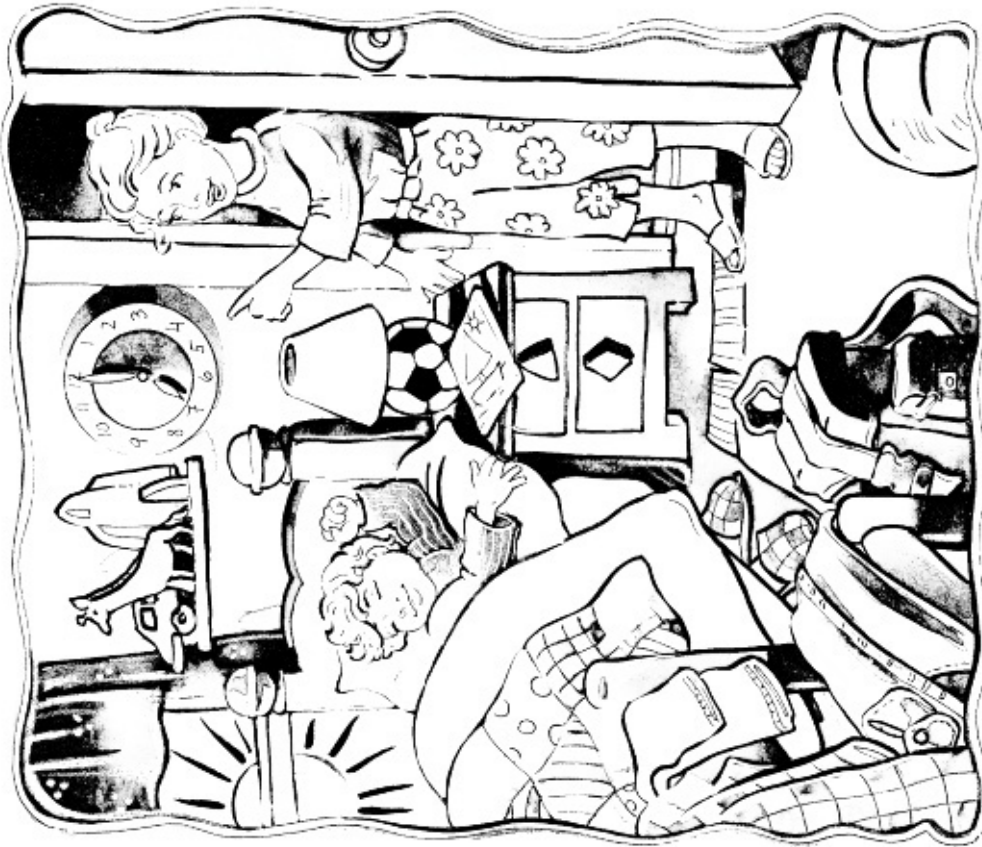

See the

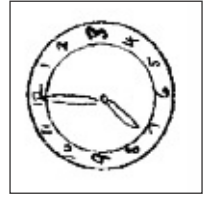

clock

?

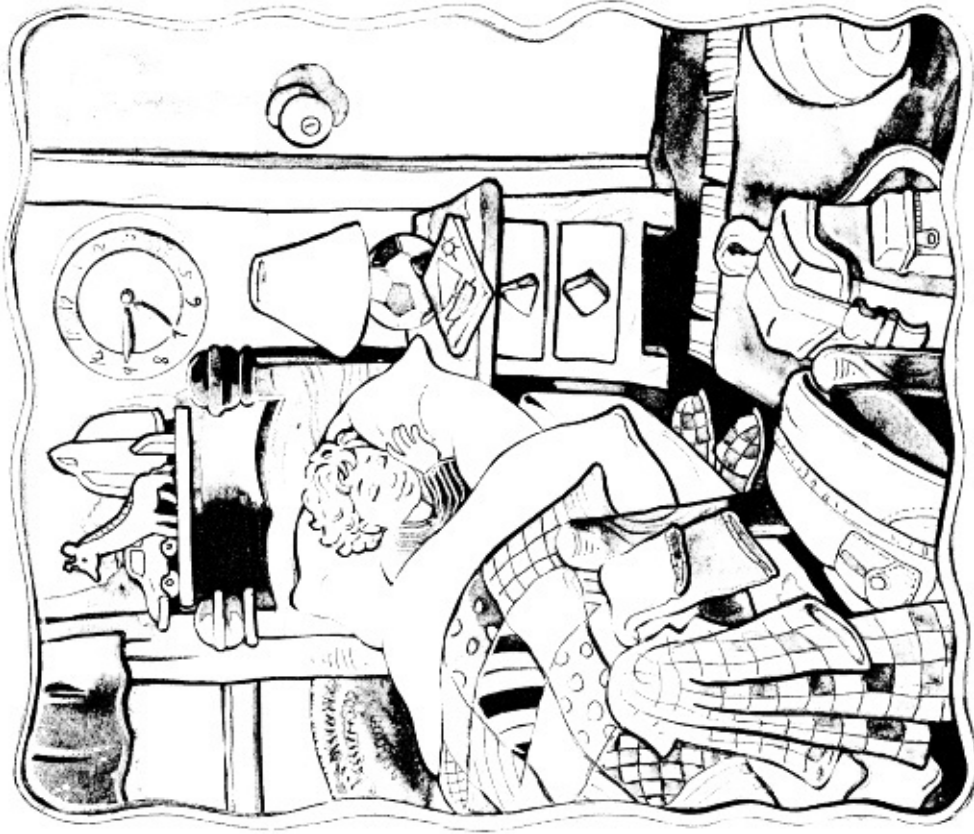

Is the

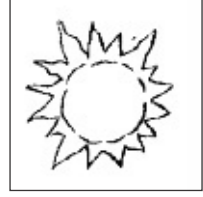

sun

up?

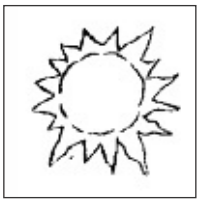

The sun is up.

4

sun

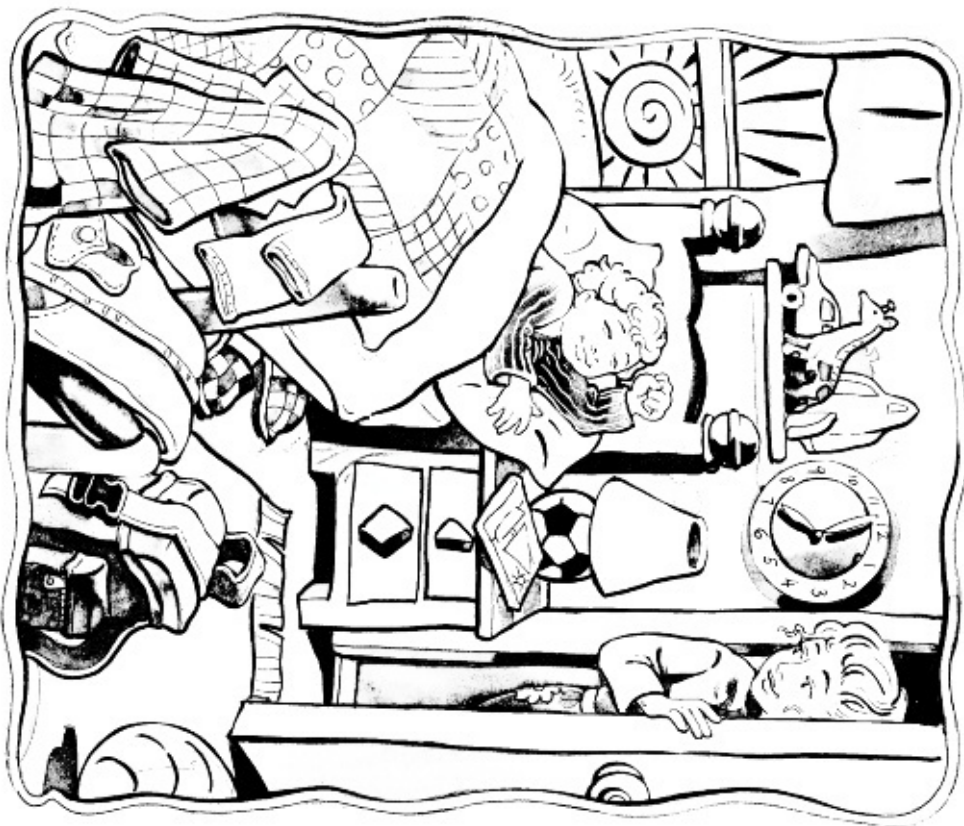

Is the boy up?

5

boy

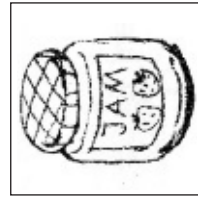
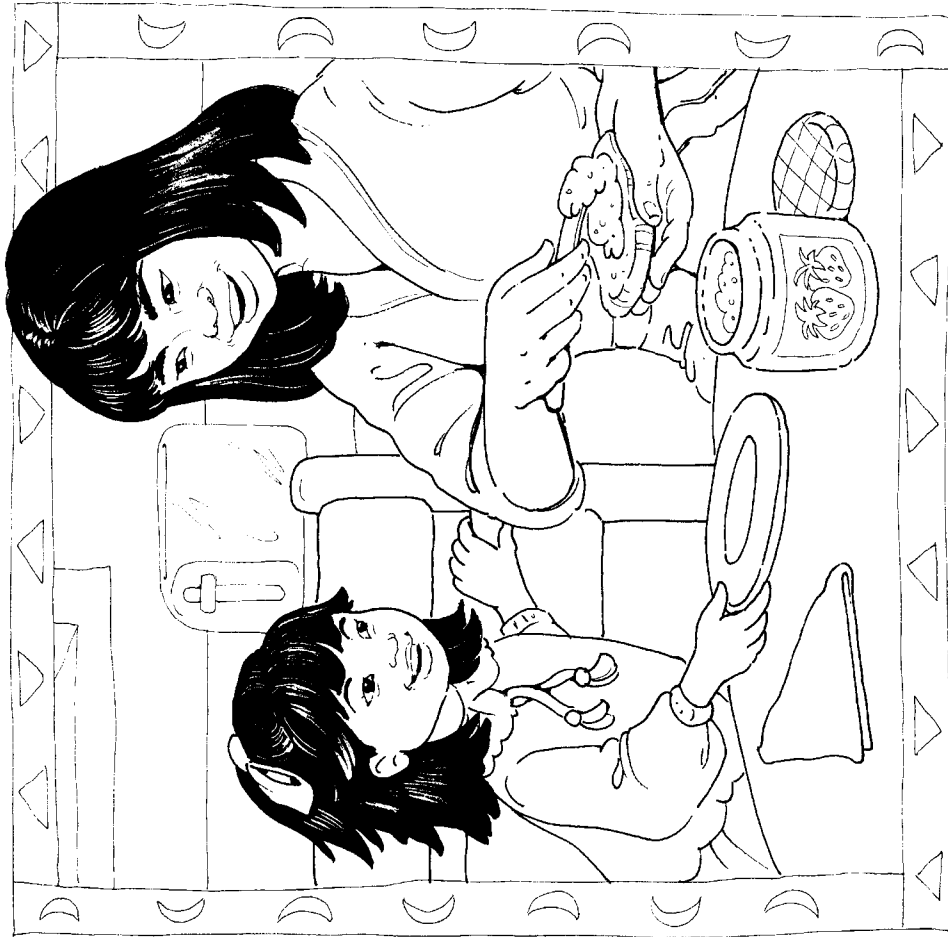

I have

jam

# I Have

by Cameron Grieff  
illustrated by Eva Vagreti

Core Decodable 3



Bothell, WA • Chicago, IL • Columbus, OH • New York, NY





I have

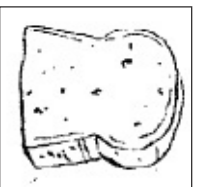

toast

MHEonline.com



Copyright © 2015 McGraw-Hill Education

All rights reserved. The contents, or parts thereof, may be reproduced in print form for non-profit educational use with *SRA Open Court Reading*, provided such reproductions bear copyright notice, but may not be reproduced in any form for any other purpose without the prior written consent of McGraw-Hill Education, including, but not limited to, network storage or transmission, or broadcast for distance learning.

Send all inquiries to:  
McGraw-Hill Education  
8787 Orion Place  
Columbus, OH 43240



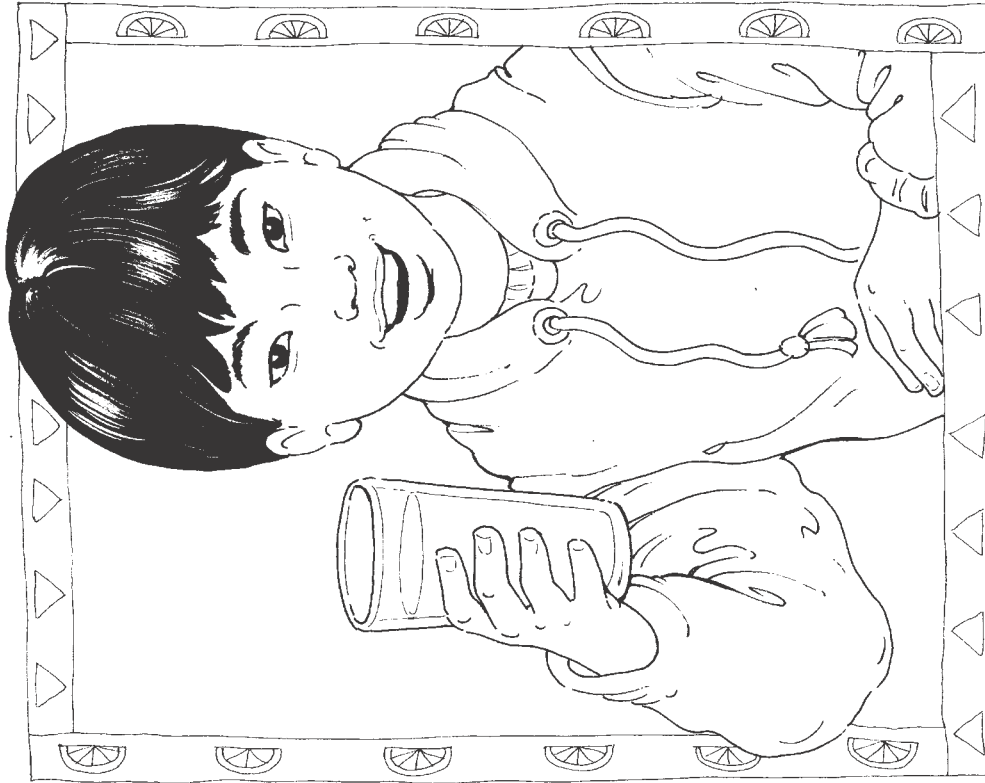

I have

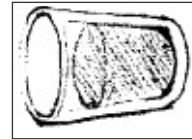

orange juice



I have

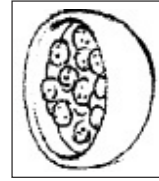

cereal

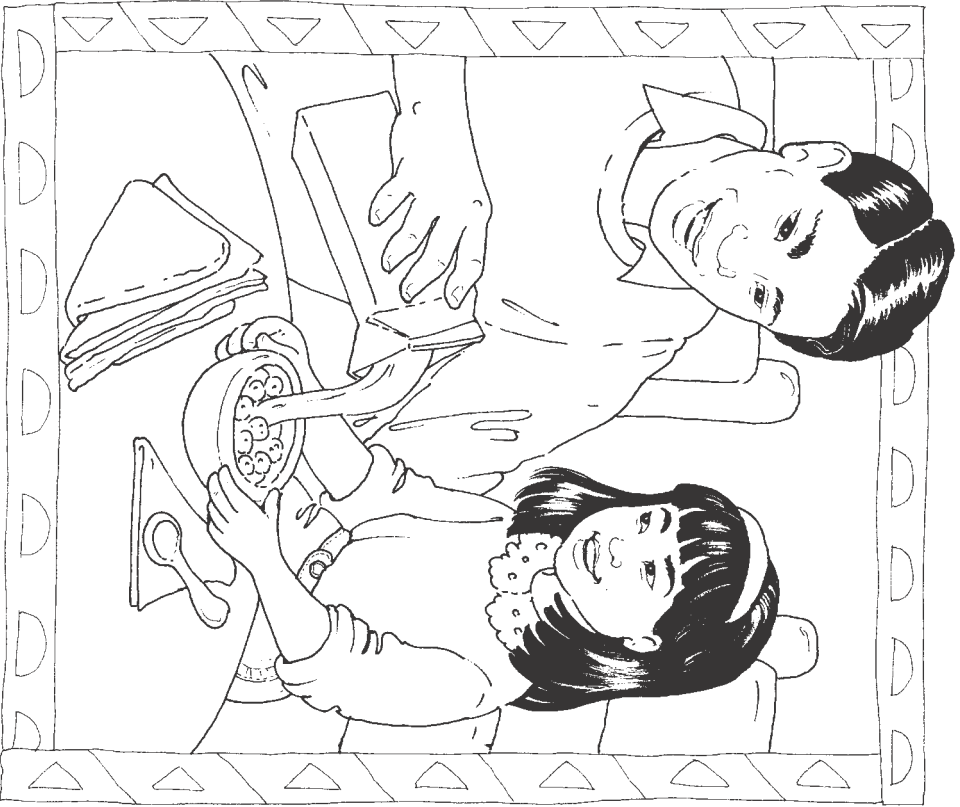

I have

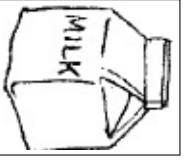

milk

4



I have

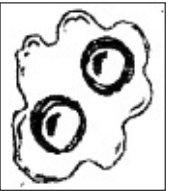

eggs

5

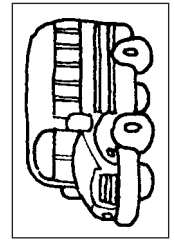
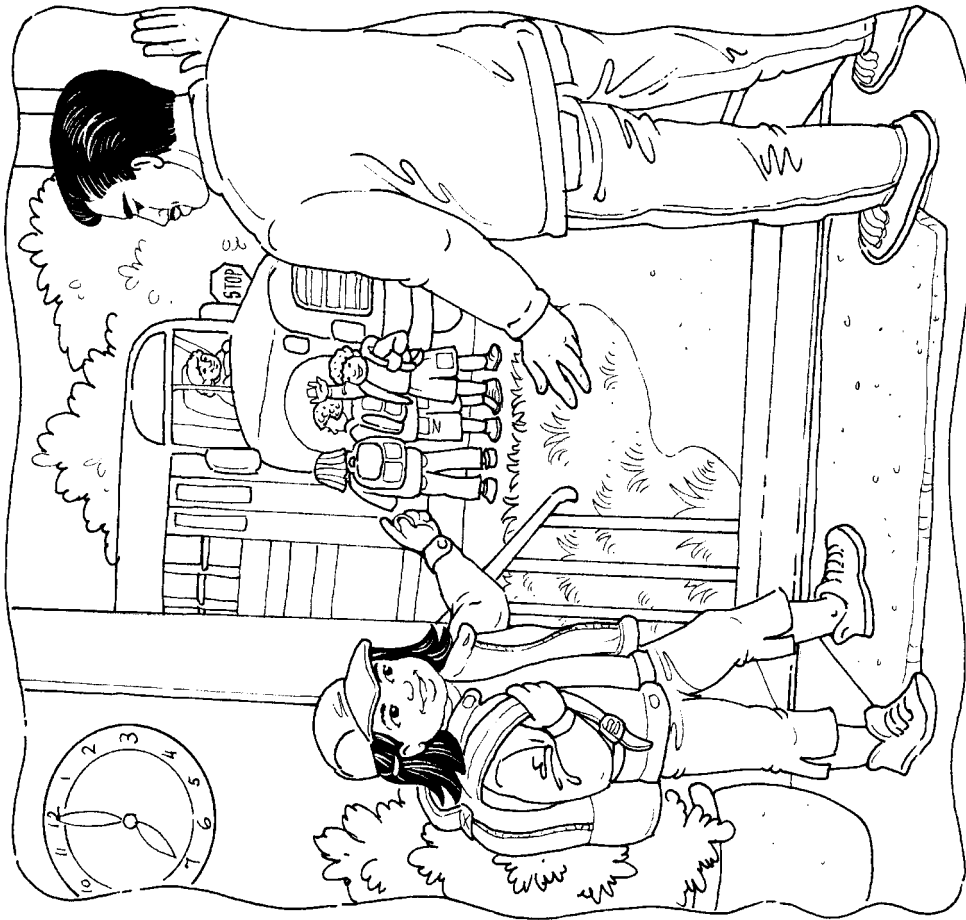

bus

There is the

# There Is

by Tameron Dennis  
illustrated by Eva Vagreti

Core Decodable 4



Bothell, WA • Chicago, IL • Columbus, OH • New York, NY

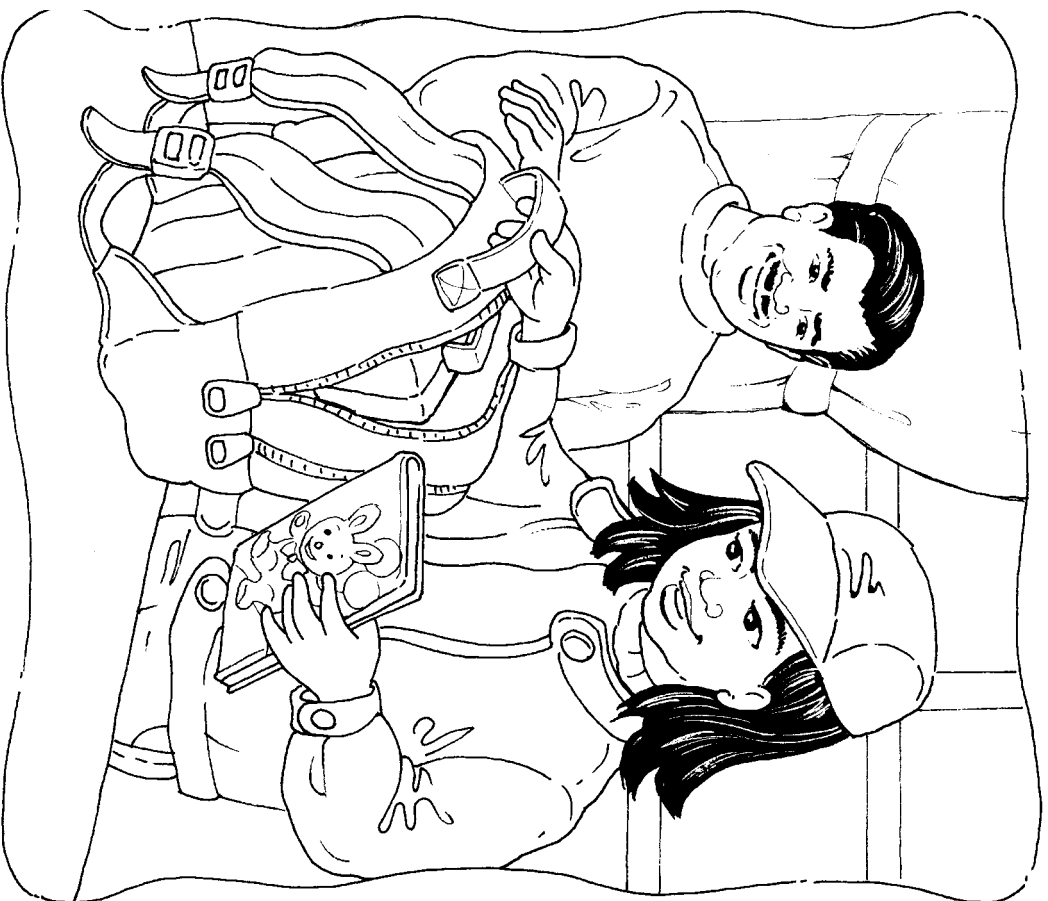

There is a

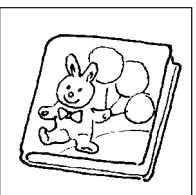

book

MHEonline.com



Copyright © 2015 McGraw-Hill Education

All rights reserved. The contents, or parts thereof, may be reproduced in print form for non-profit educational use with *SRA Open Court Reading*, provided such reproductions bear copyright notice, but may not be reproduced in any form for any other purpose without the prior written consent of McGraw-Hill Education, including, but not limited to, network storage or transmission, or broadcast for distance learning.

Send all inquiries to:  
 McGraw-Hill Education  
 8787 Orion Place  
 Columbus, OH 43240

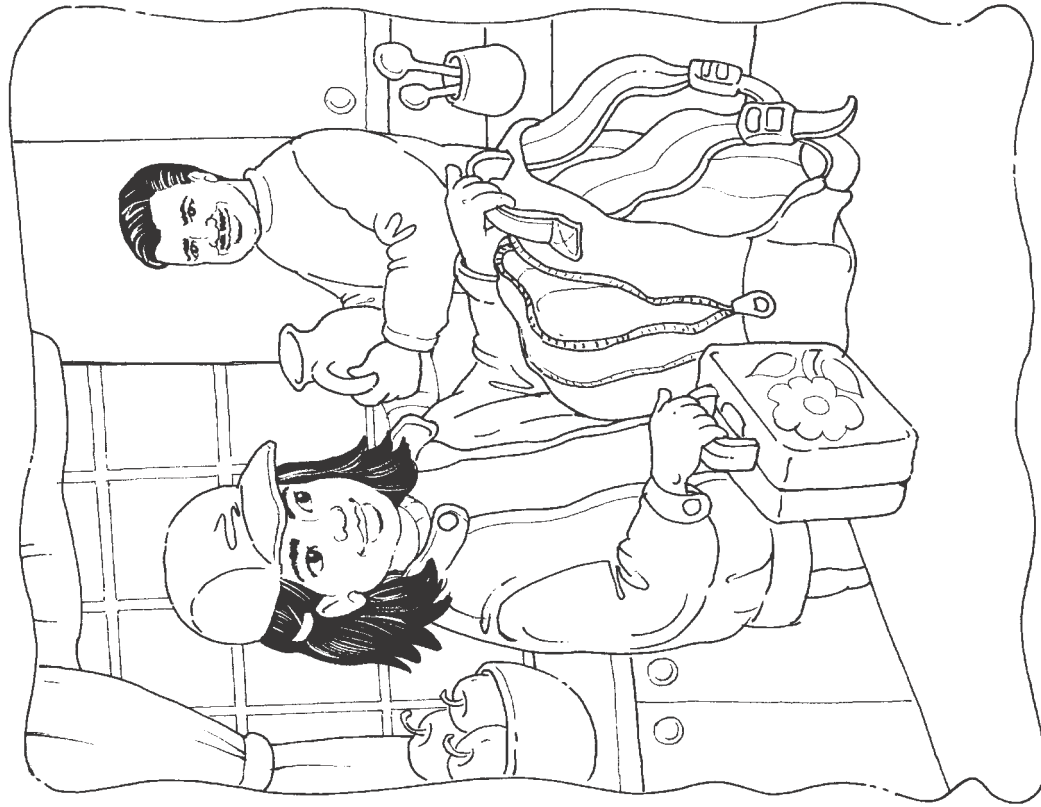

There is a

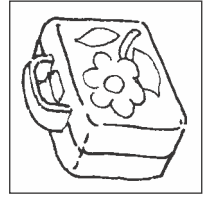

lunchbox

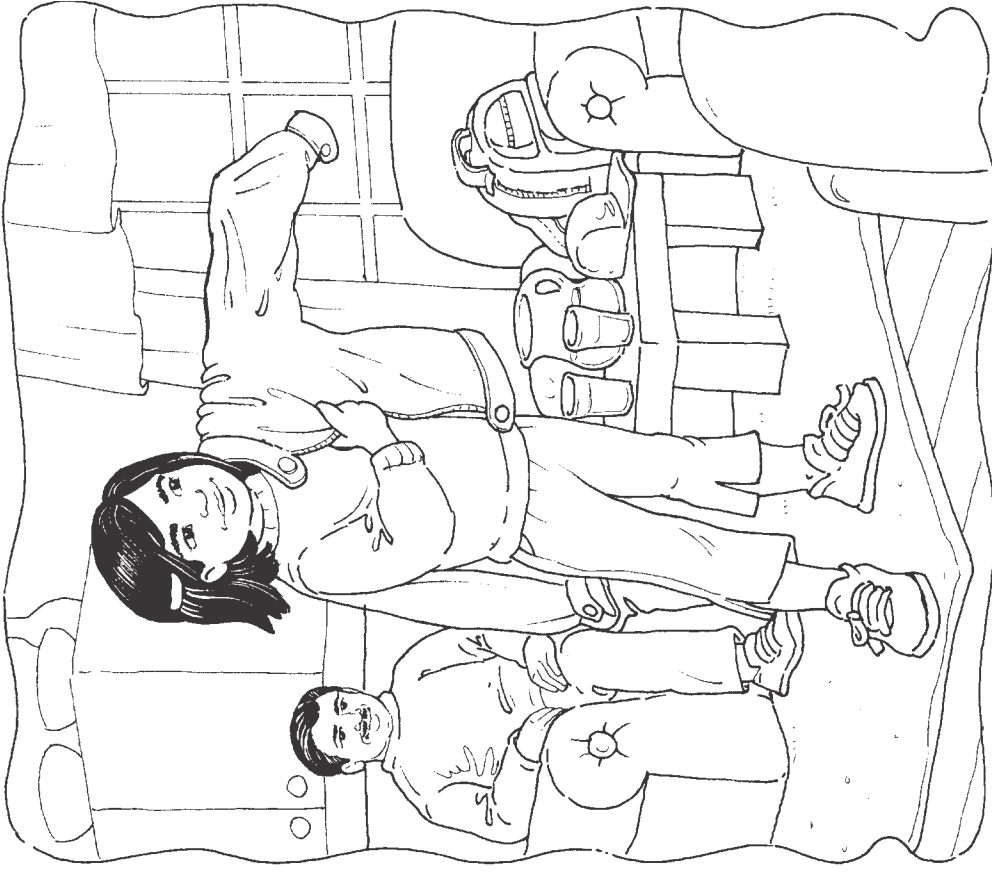

There is a

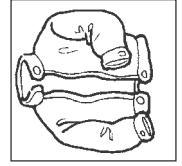

jacket



There is a

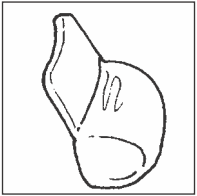

cap

4



There is a

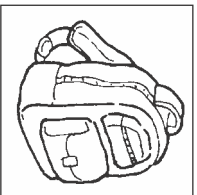

backpack

5

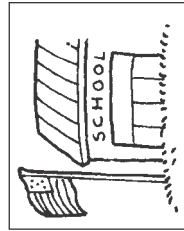
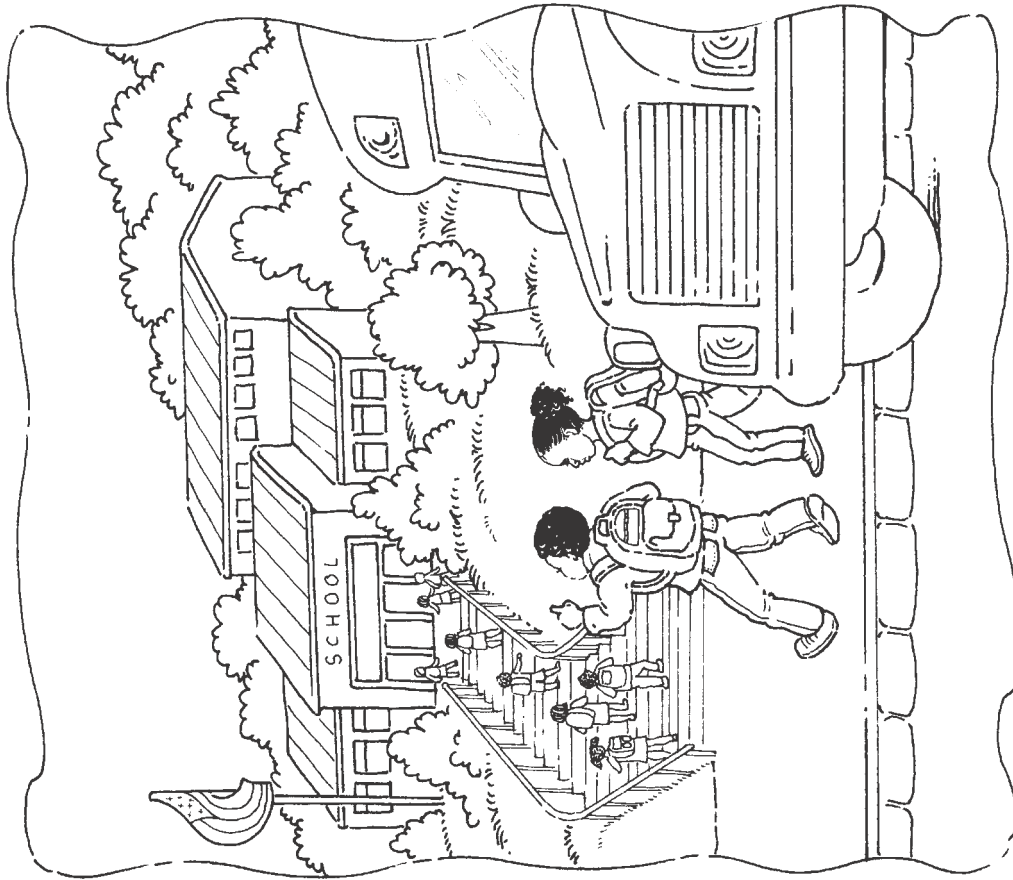

school

I can see the

# I Can See

by Cameron Grieff  
illustrated by Eva Vagreti

Core Decodable 5



Bothell, WA • Chicago, IL • Columbus, OH • New York, NY





I can see



girls

on the

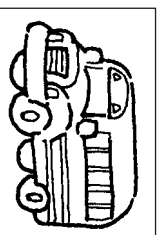

bus

7

MHEonline.com



Copyright © 2015 McGraw-Hill Education

All rights reserved. The contents, or parts thereof, may be reproduced in print form for non-profit educational use with *SRA Open Court Reading*, provided such reproductions bear copyright notice, but may not be reproduced in any form for any other purpose without the prior written consent of McGraw-Hill Education, including, but not limited to, network storage or transmission, or broadcast for distance learning.

Send all inquiries to:  
McGraw-Hill Education  
8787 Orion Place  
Columbus, OH 43240

2





I can see



boys

on the

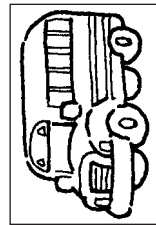

bus

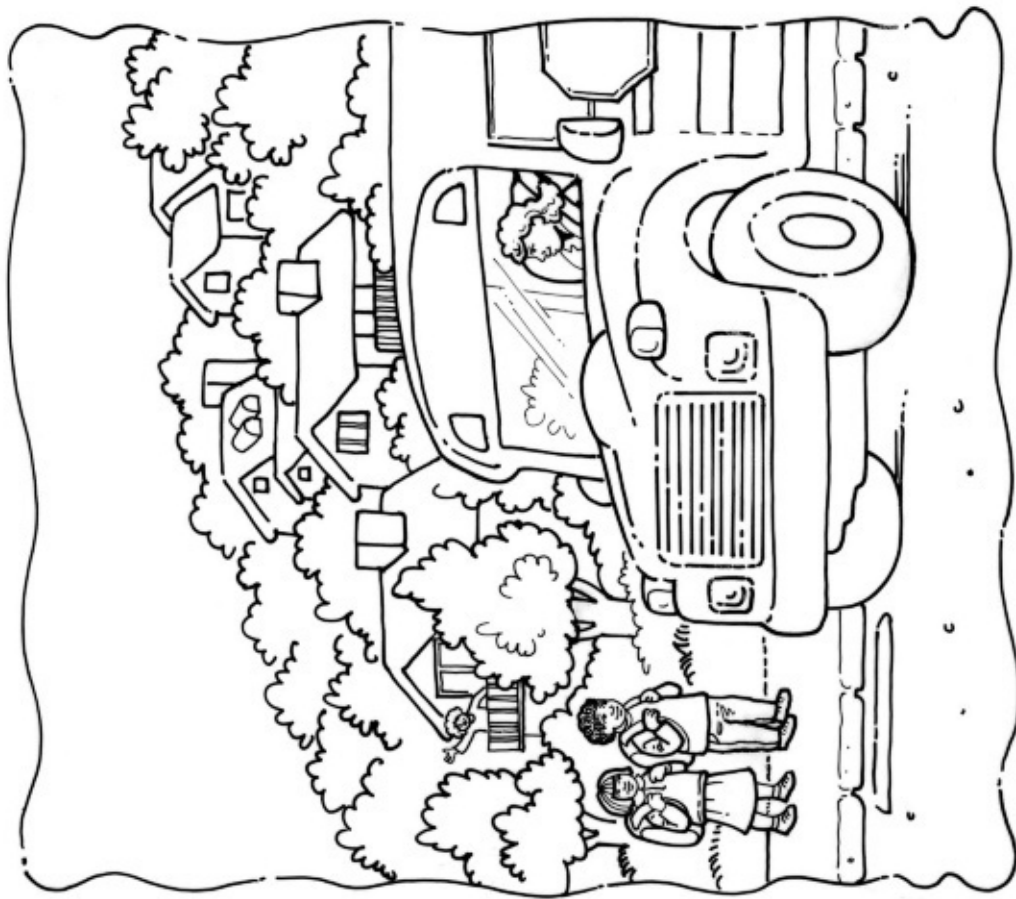

I can see the

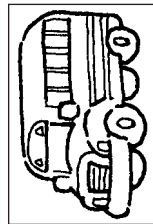

bus

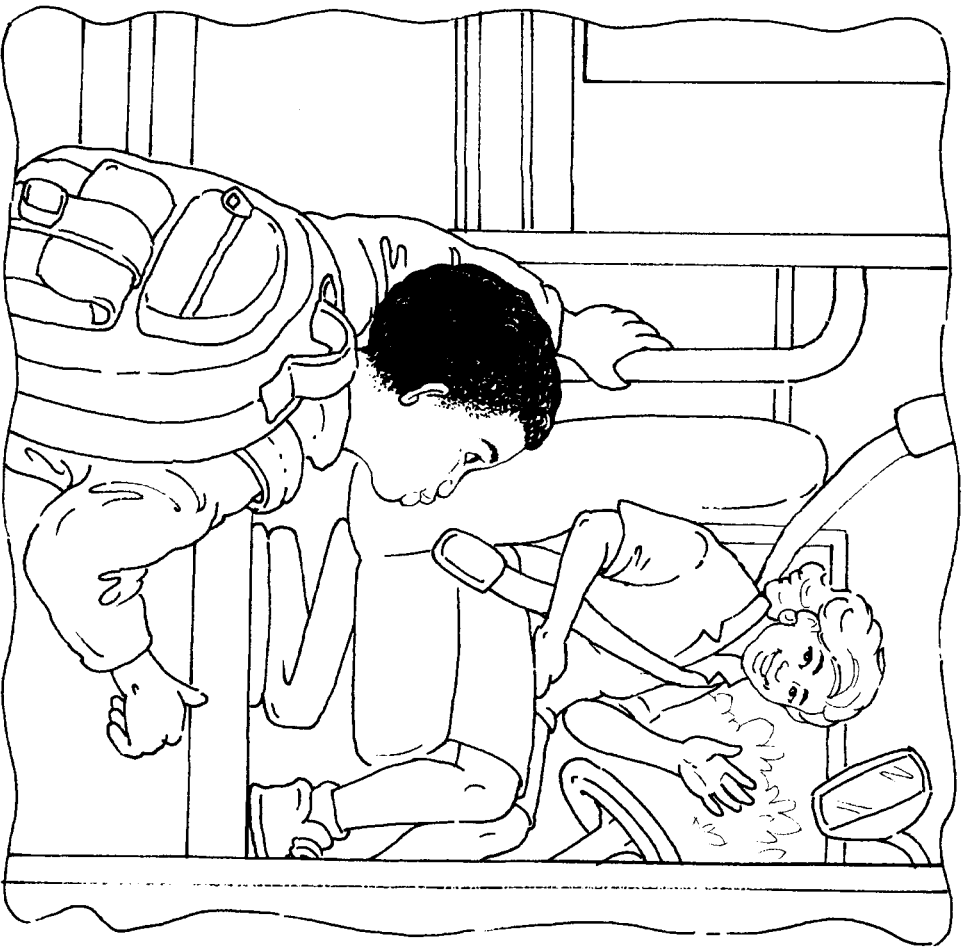

I can see the

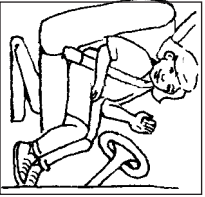

bus driver

on the

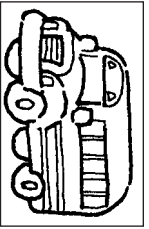

bus

4

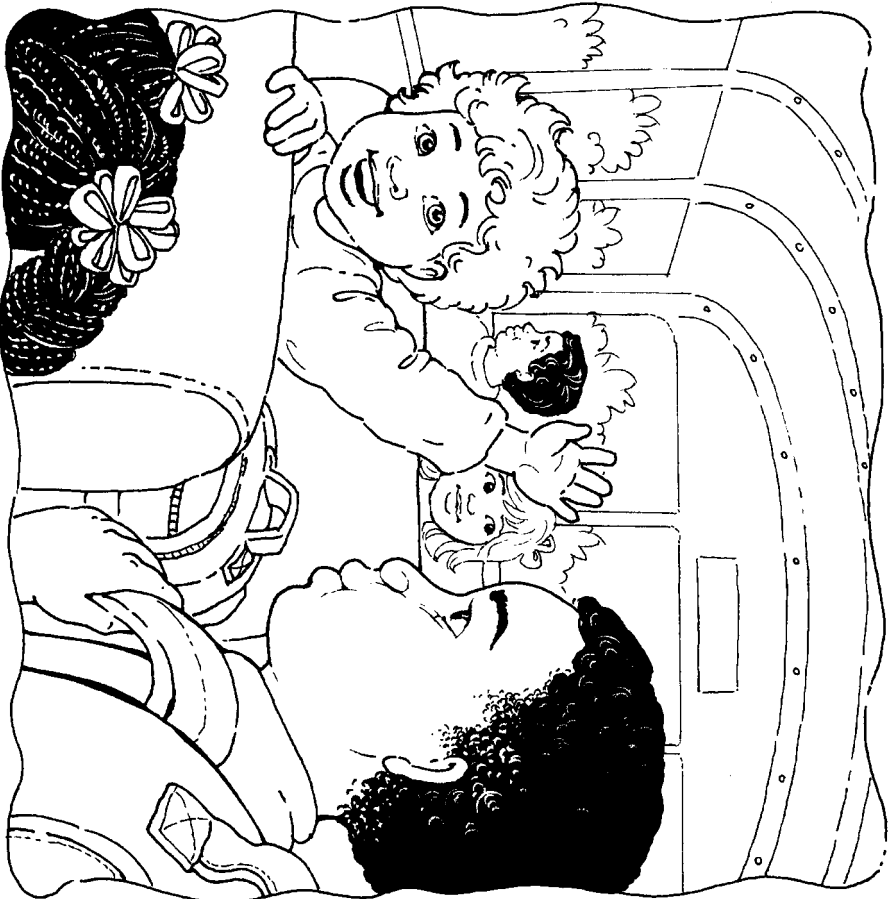

I can see a



boy

on the

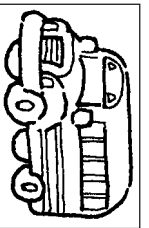

bus

5



I am Sam.

# Sam, Sam, Sam

by Linda Cave  
illustrated by Meryl Henderson

Core Decodable 6



Bothell, WA • Chicago, IL • Columbus, OH • New York, NY



Sam, Sam, Sam.

MHEonline.com



Copyright © 2015 McGraw-Hill Education

All rights reserved. The contents, or parts thereof, may be reproduced in print form for non-profit educational use with *SRA Open Court Reading*, provided such reproductions bear copyright notice, but may not be reproduced in any form for any other purpose without the prior written consent of McGraw-Hill Education, including, but not limited to, network storage or transmission, or broadcast for distance learning.

Send all inquiries to:  
McGraw-Hill Education  
8787 Orion Place  
Columbus, OH 43240



Sam?



I am Sam.

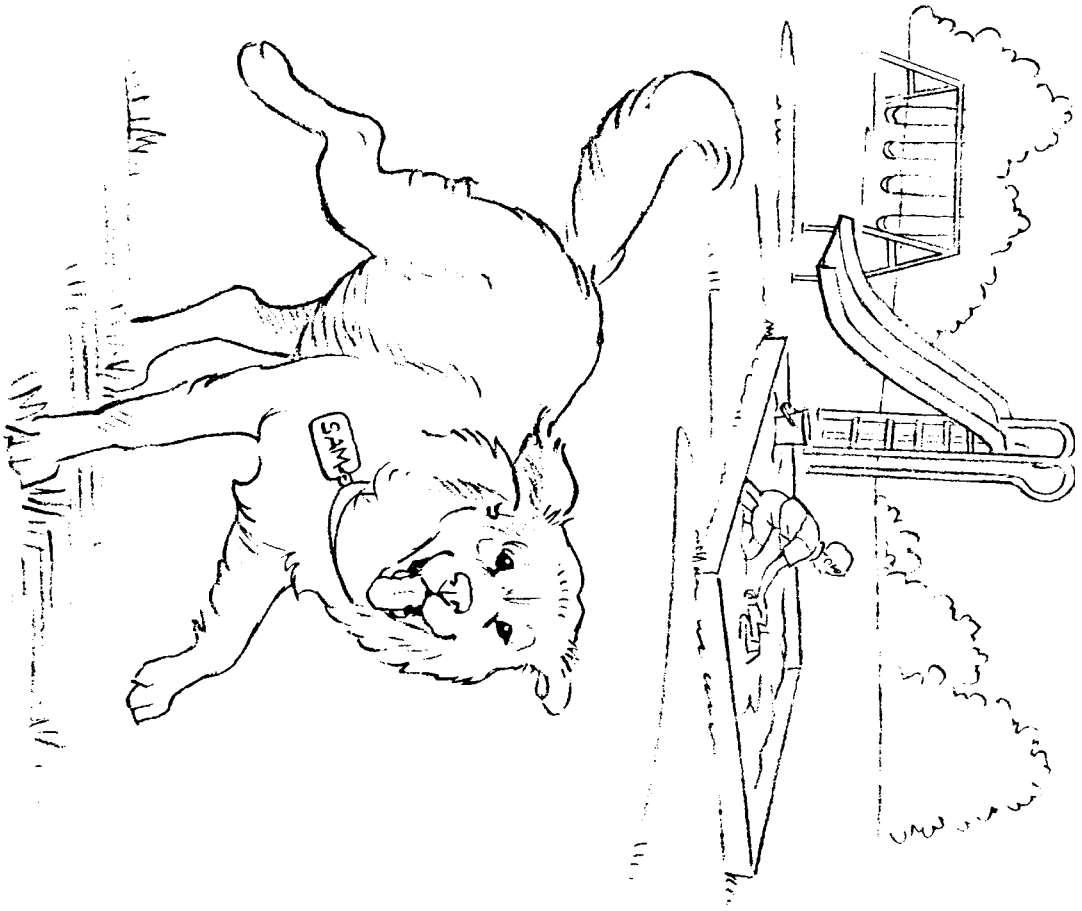

I am Sam.

4



I am Sam.

5

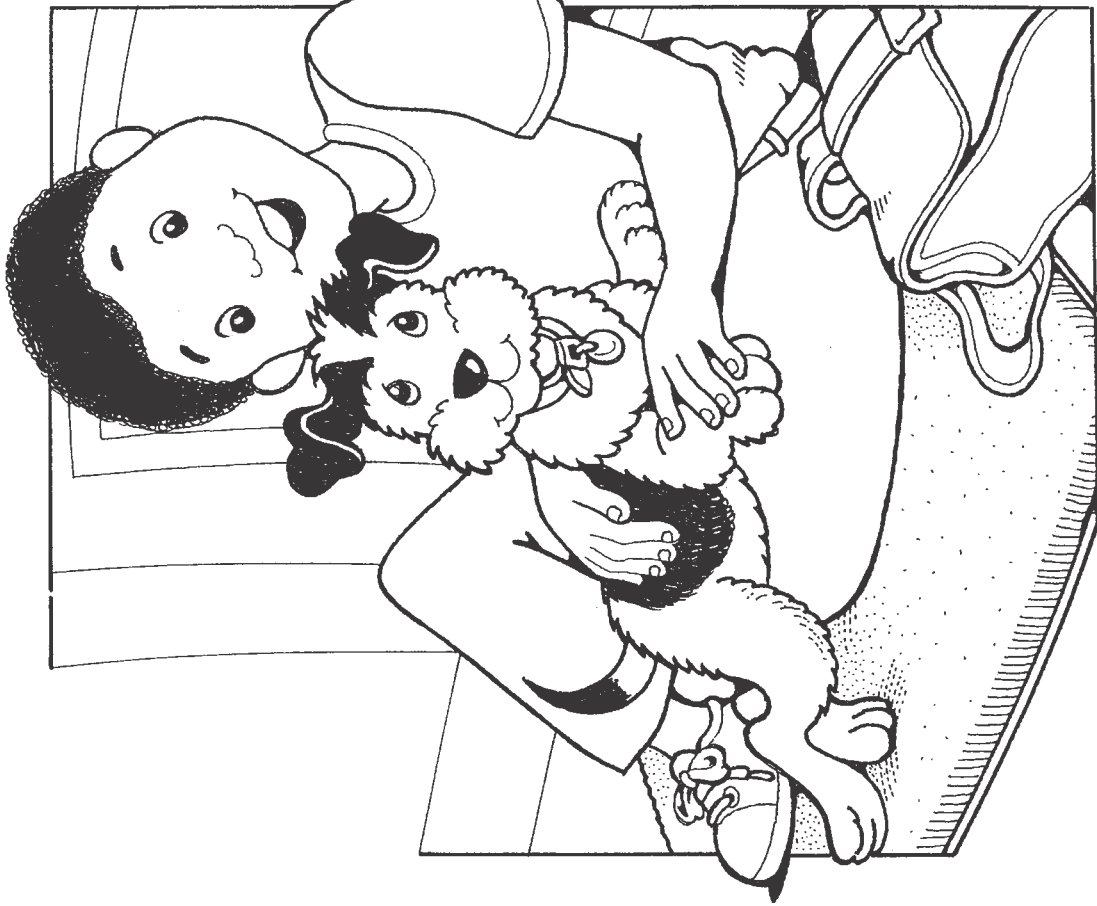

Sam and Matt sat.

# Matt and Sam

by Martha Wood  
illustrated by Olivia Cole

Core Decodable 7



Bothell, WA • Chicago, IL • Columbus, OH • New York, NY

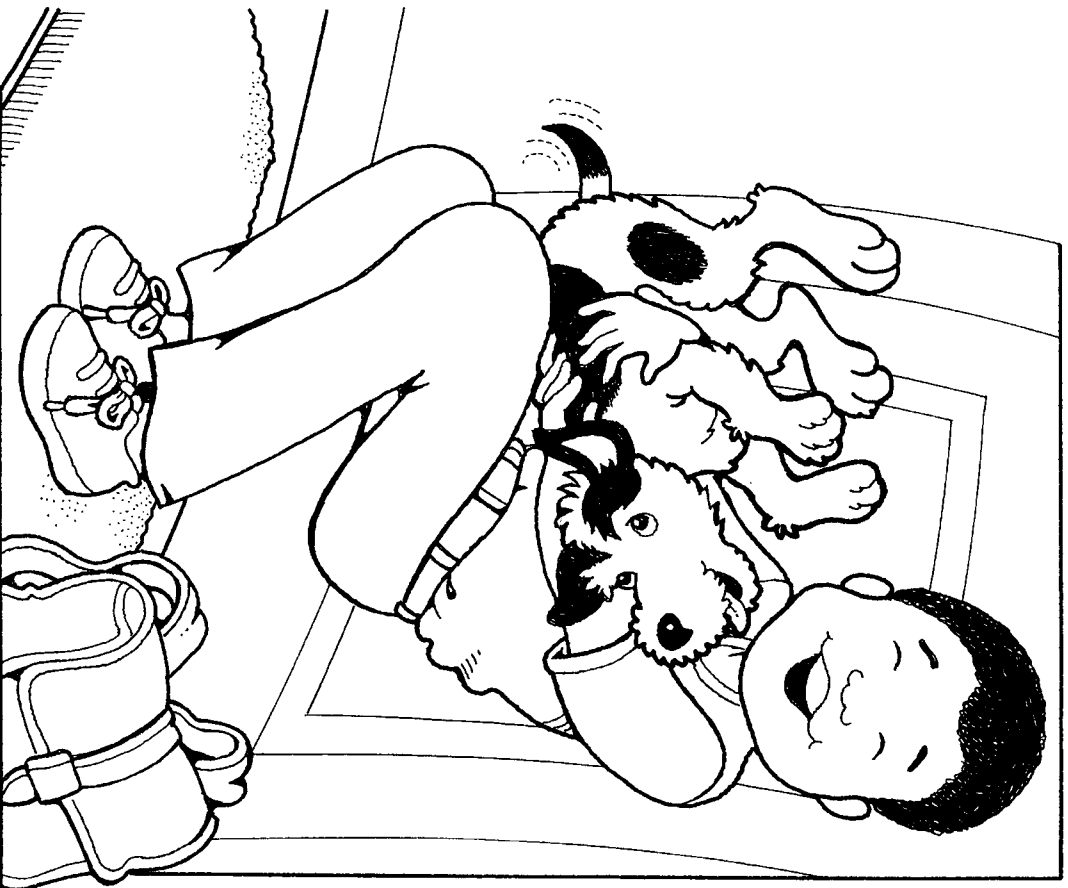

Sam sat.

MHEonline.com



Copyright © 2015 McGraw-Hill Education

All rights reserved. The contents, or parts thereof, may be reproduced in print form for non-profit educational use with *SRA Open Court Reading*, provided such reproductions bear copyright notice, but may not be reproduced in any form for any other purpose without the prior written consent of McGraw-Hill Education, including, but not limited to, network storage or transmission, or broadcast for distance learning.

Send all inquiries to:  
McGraw-Hill Education  
8787 Orion Place  
Columbus, OH 43240





Sam



Matt

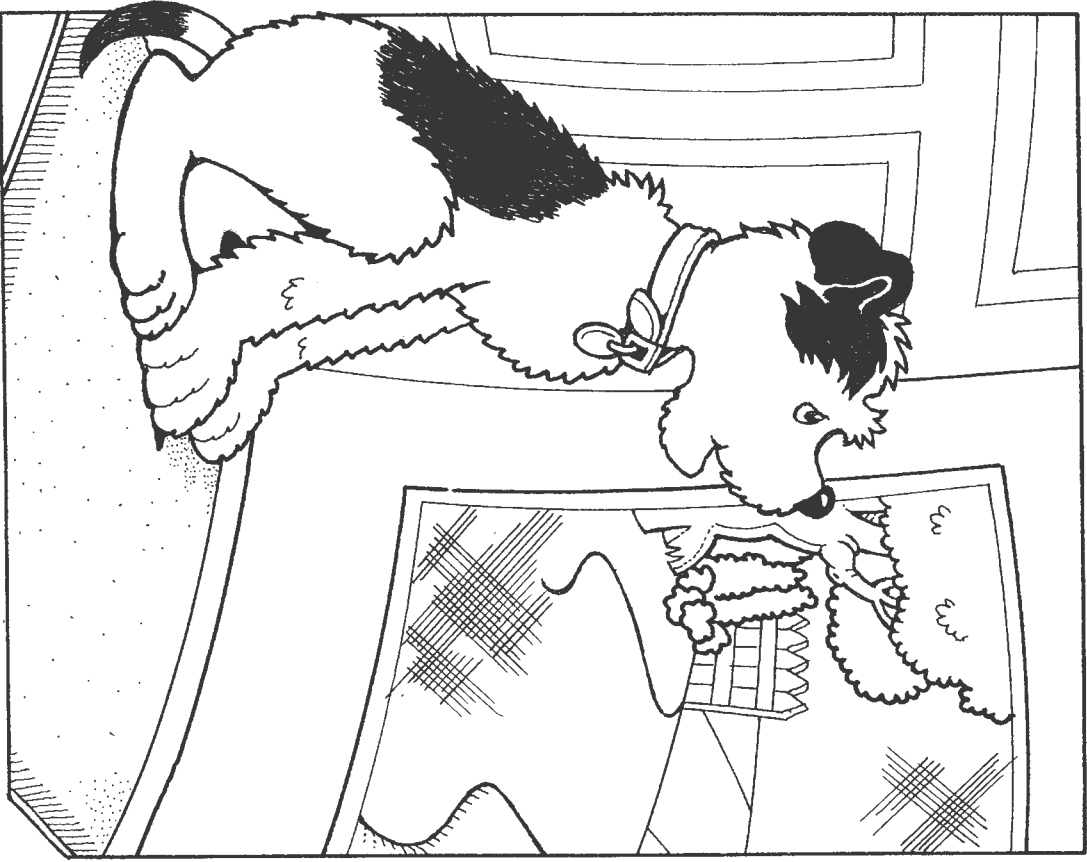

4

Matt sat.



5

Matt sat on Sam.



I sat on a mat.

# On a Mat

by Tameron Dennis  
illustrated by Mark Corcoran

Core Decodable 8



Bothell, WA • Chicago, IL • Columbus, OH • New York, NY

MHEonline.com



Copyright © 2015 McGraw-Hill Education

All rights reserved. The contents, or parts thereof, may be reproduced in print form for non-profit educational use with *SRA Open Court Reading*, provided such reproductions bear copyright notice, but may not be reproduced in any form for any other purpose without the prior written consent of McGraw-Hill Education, including, but not limited to, network storage or transmission, or broadcast for distance learning.

Send all inquiries to:  
McGraw-Hill Education  
8787 Orion Place  
Columbus, OH 43240

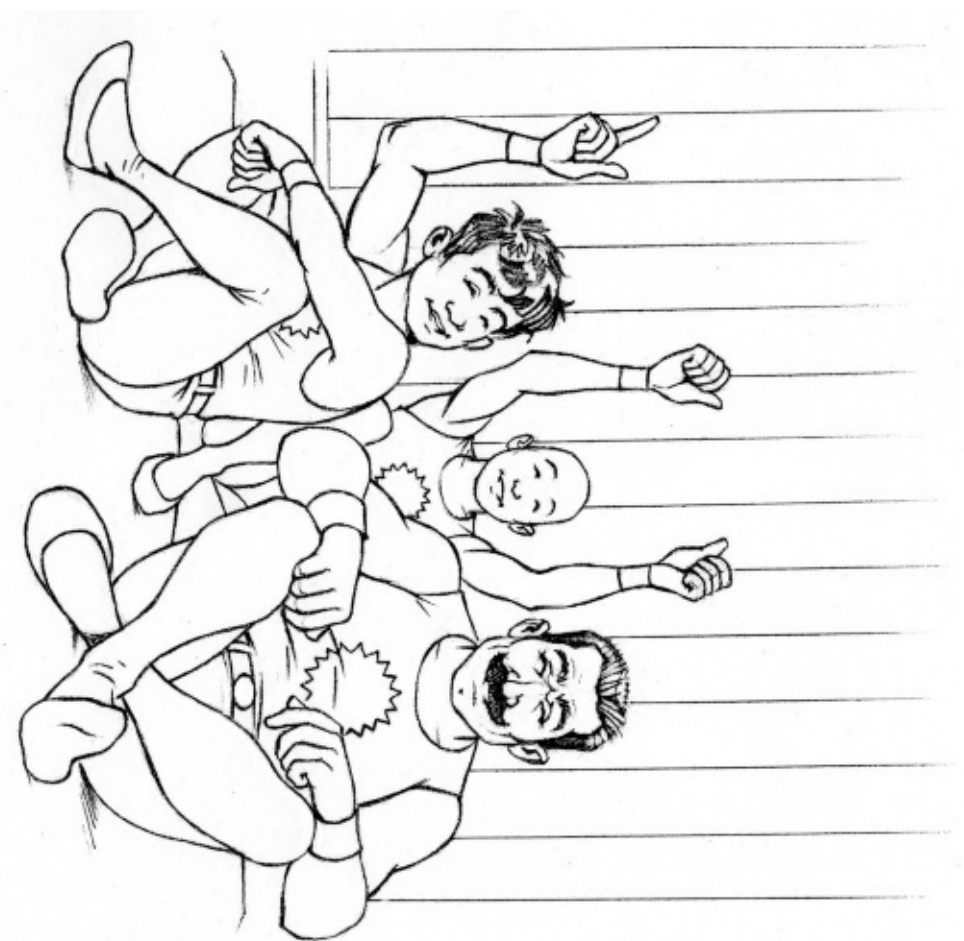

Tam sat. Sam sat. Matt sat.

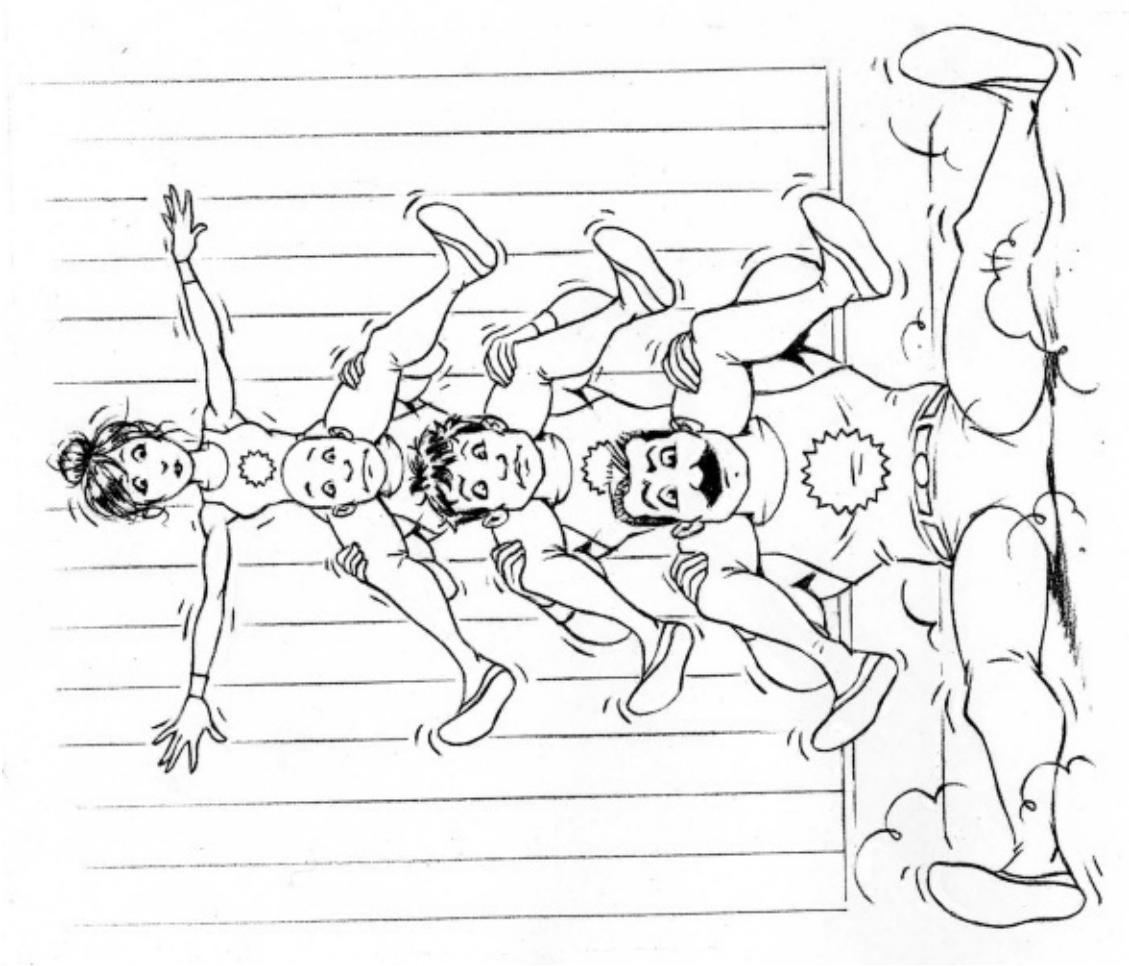

Tam sat on a mat.

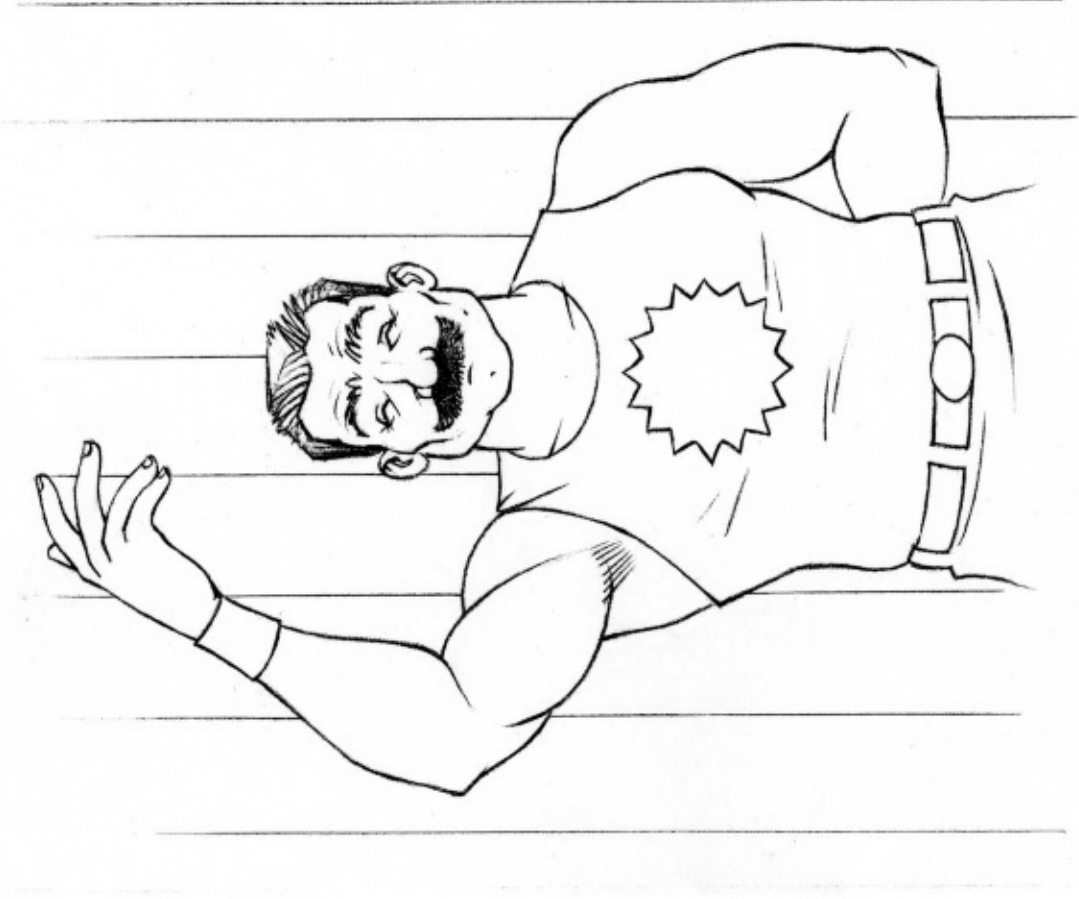

Tam



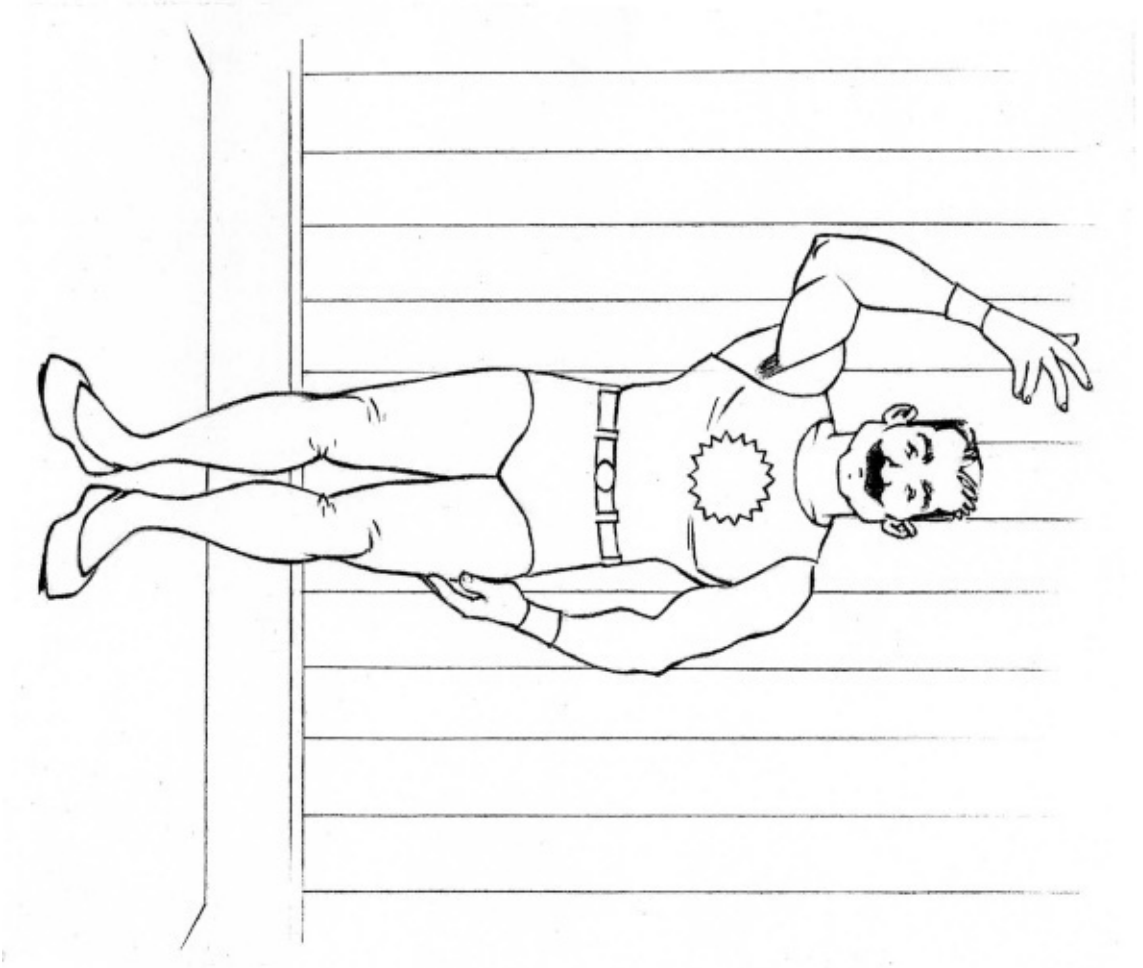

Tam on a mat

4



Tam sat.

13



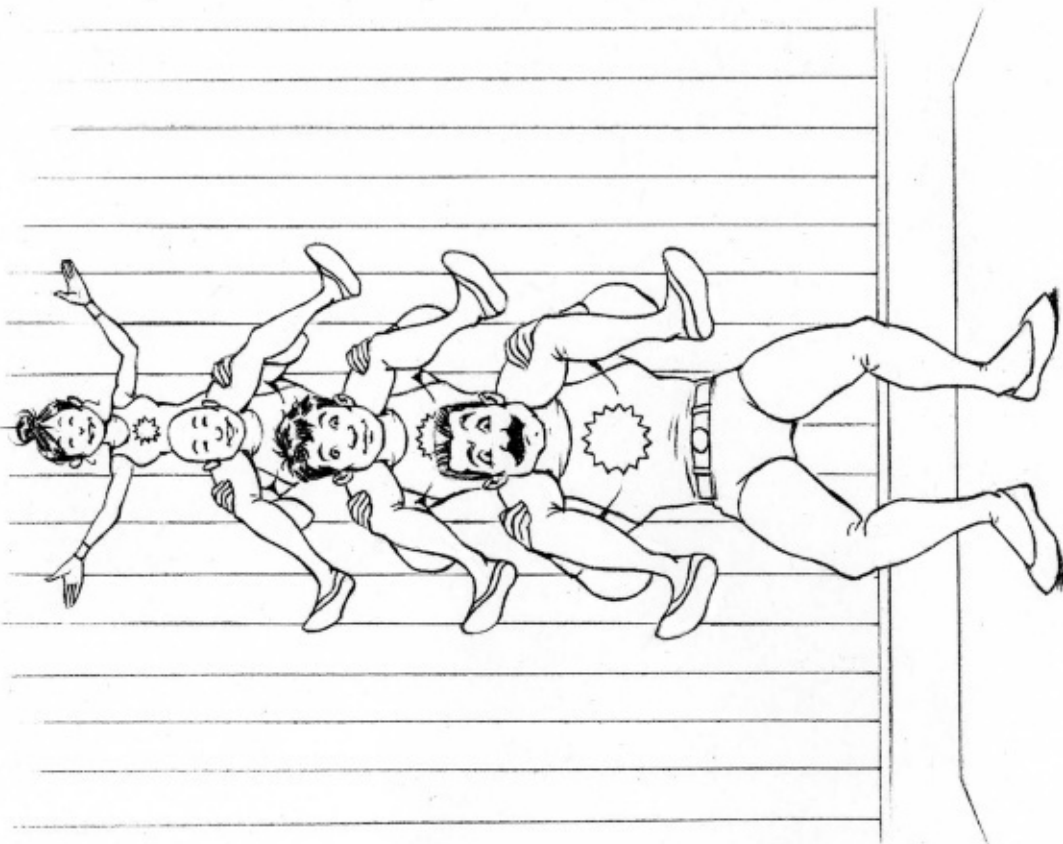

I sat on Matt.

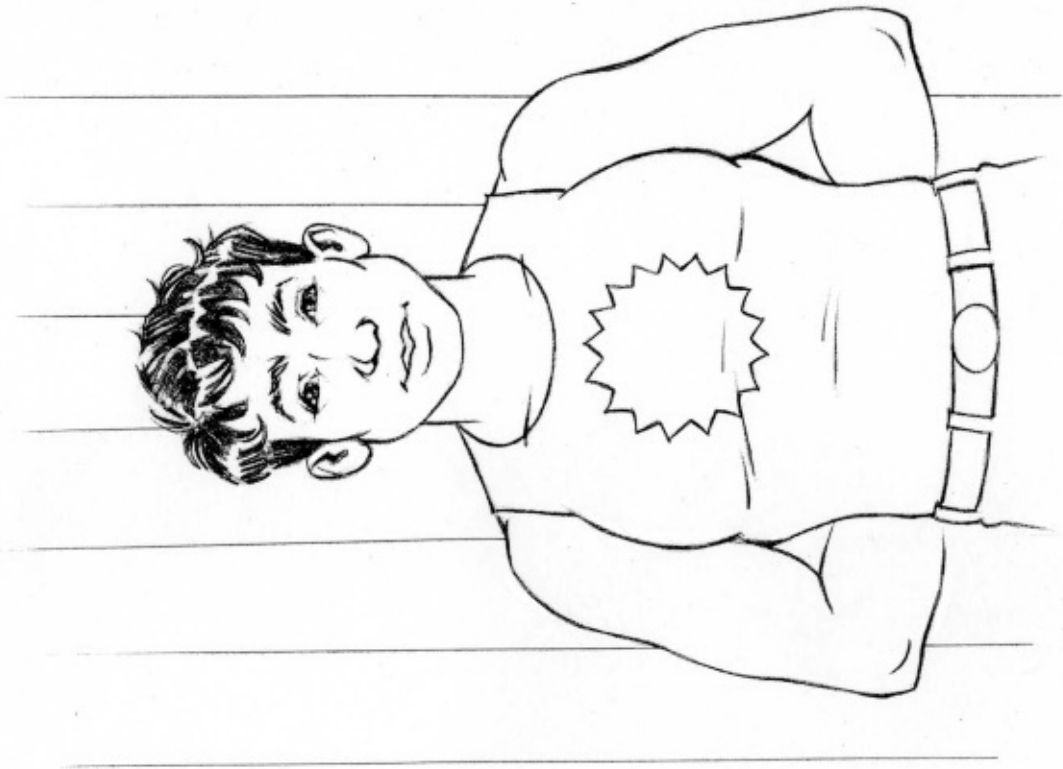

Sam

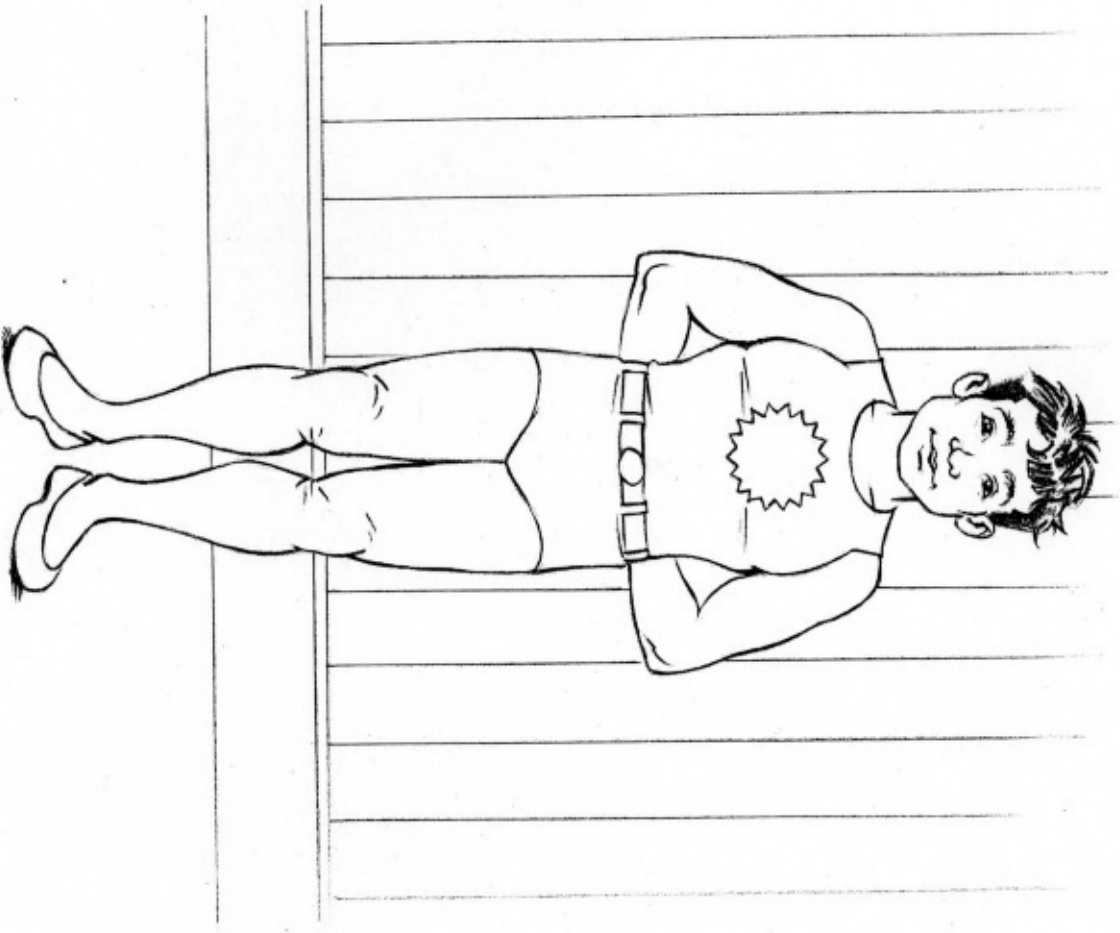

Sam on a mat

6

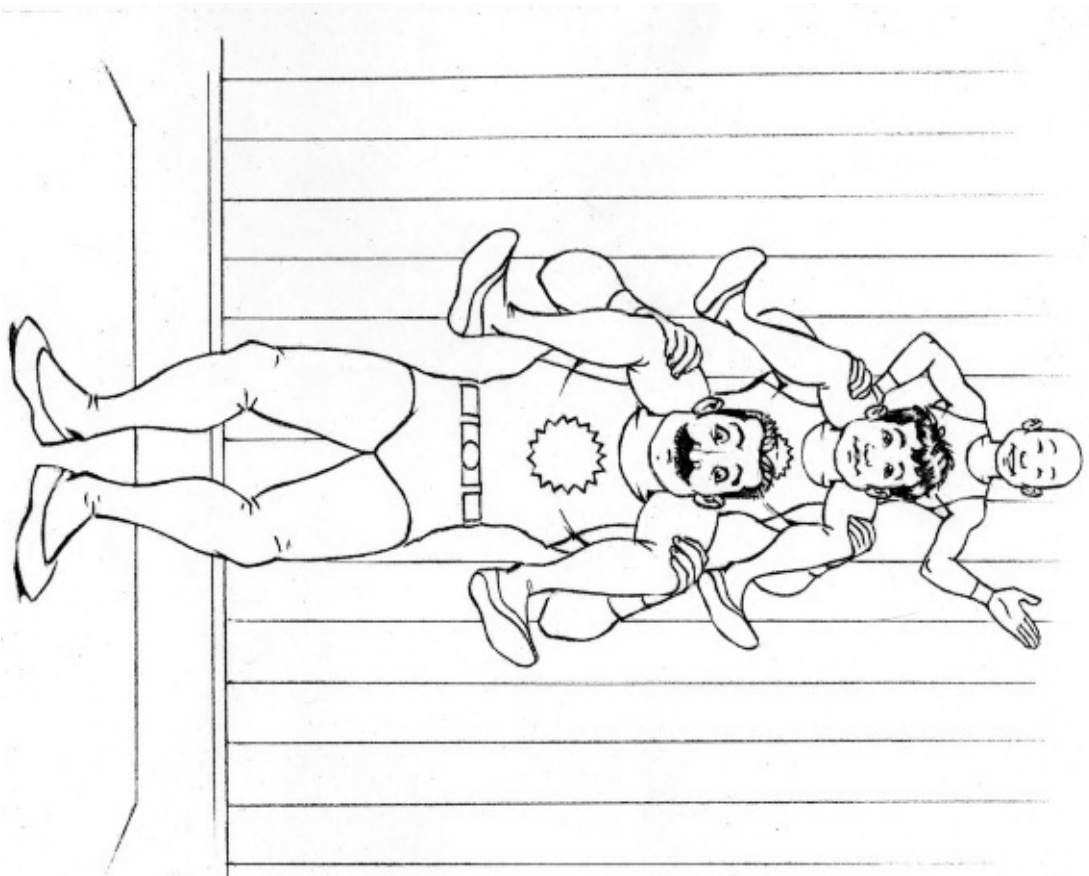

Matt sat on Sam.

11

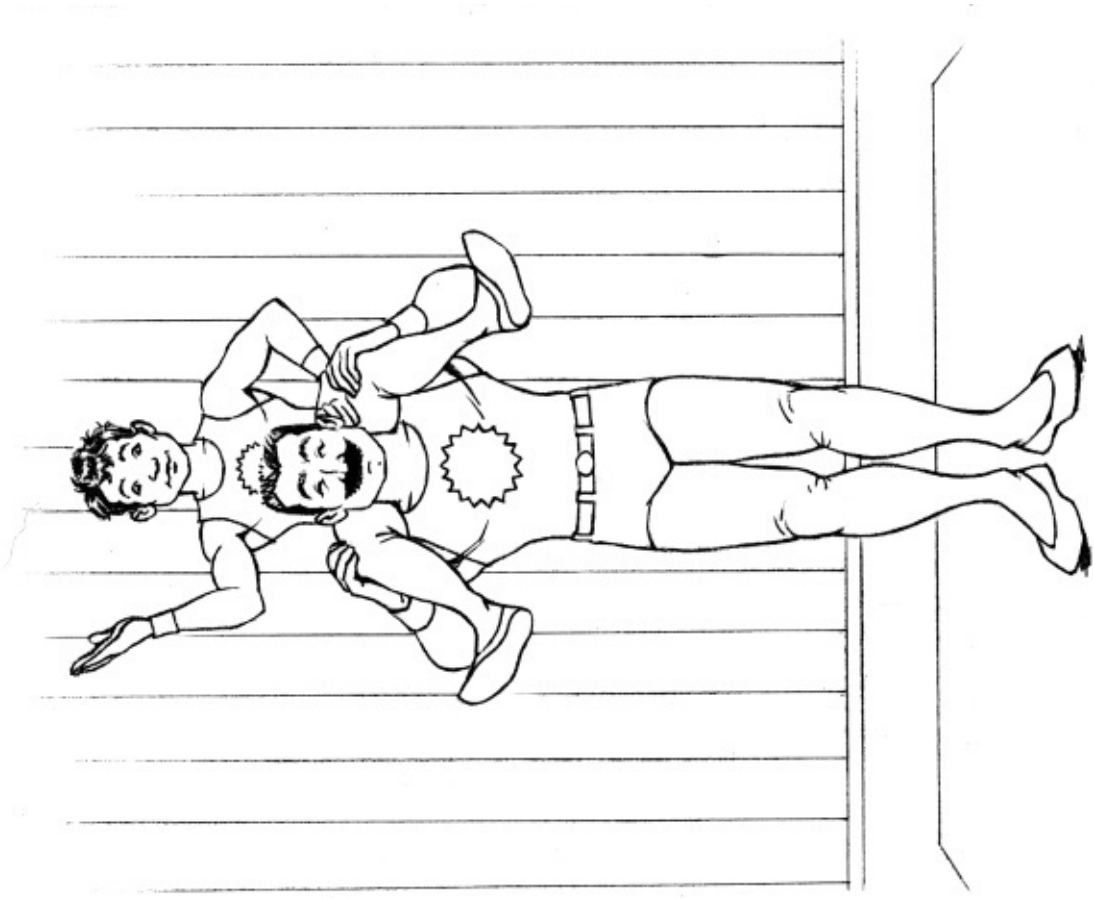

Sam sat on Tam.

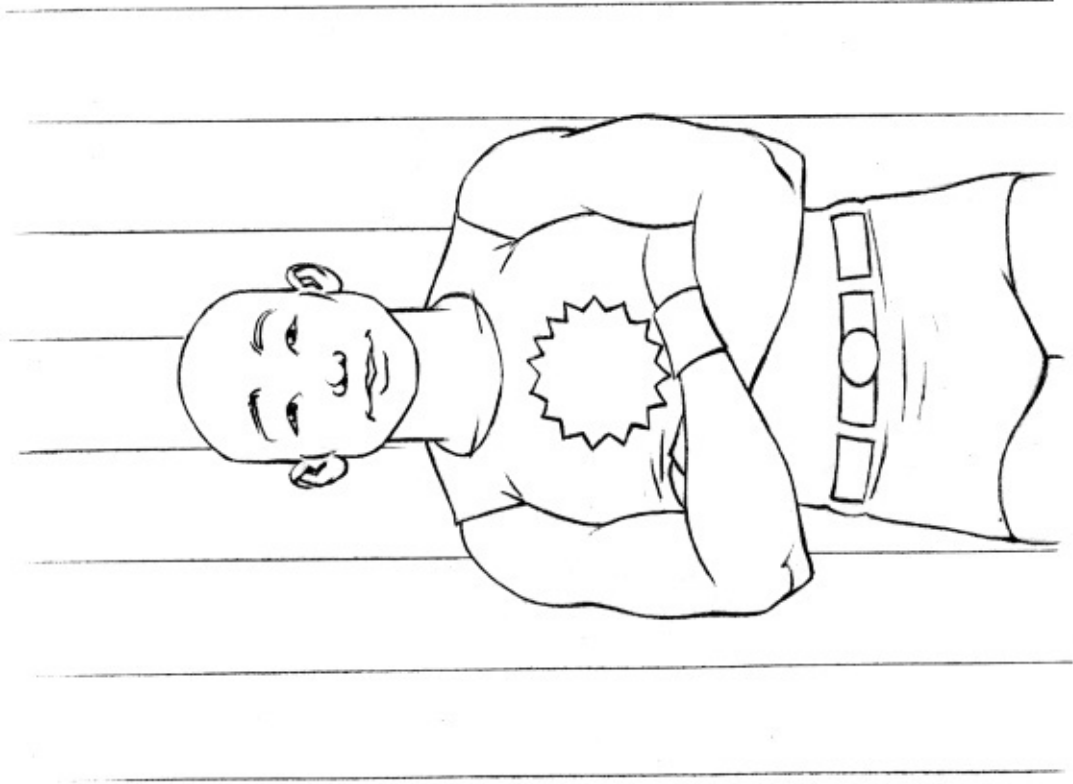

Matt

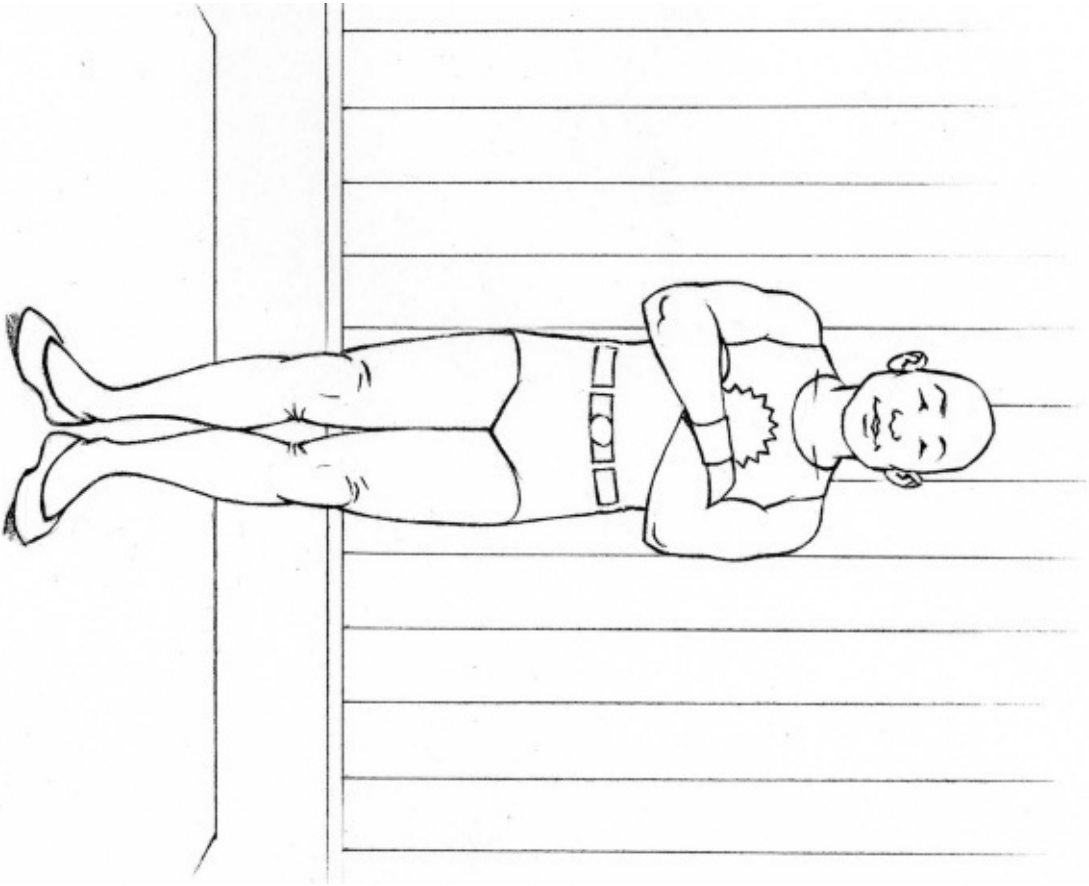

Matt on a mat

8

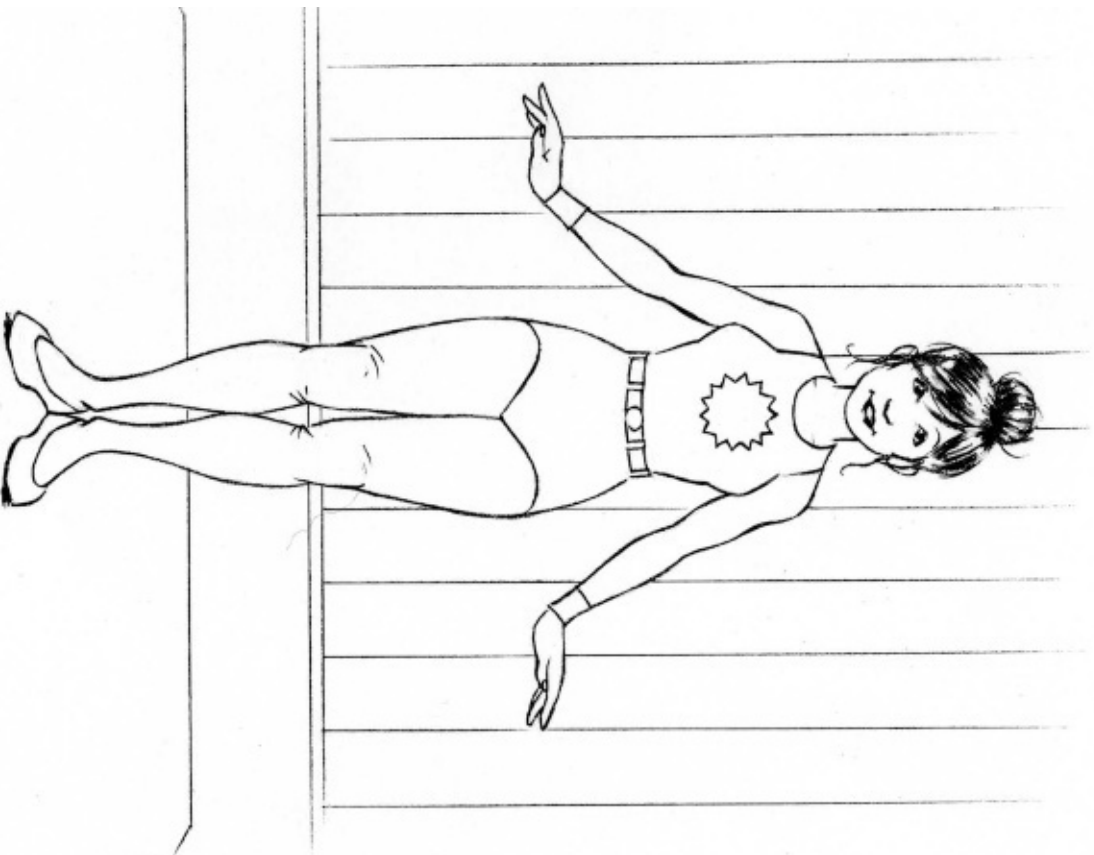

I am on a mat.

9

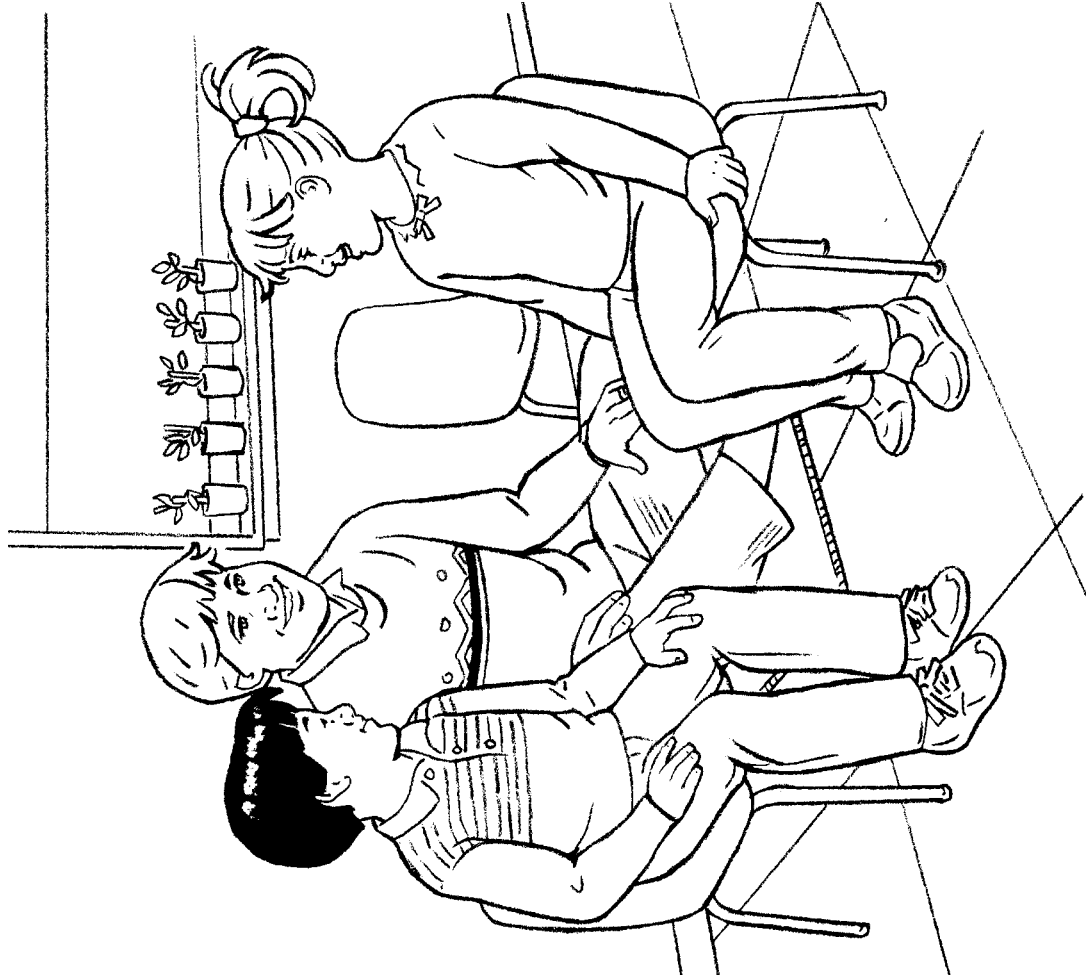

Tad, Tam, and Dad sat.

# Dad Sat

by Tamera Williams  
illustrated by Anni Matsick

Core Decodable 9



Bothell, WA • Chicago, IL • Columbus, OH • New York, NY

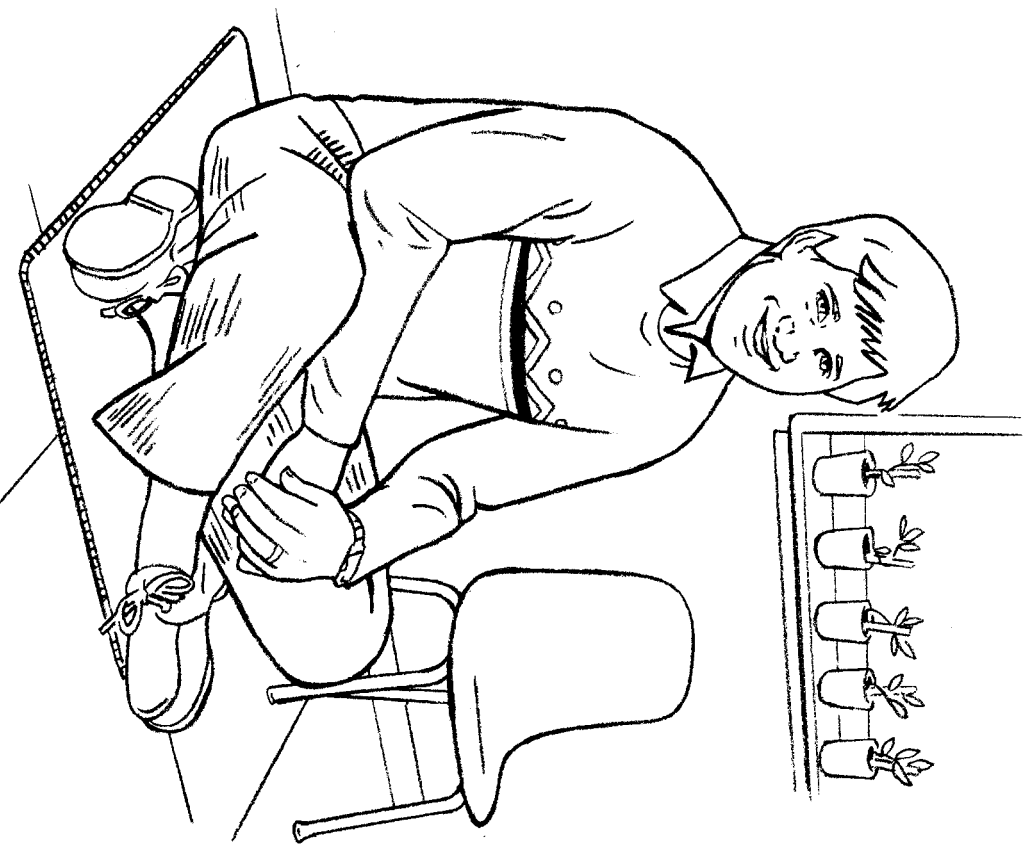

Dad sat on the mat.

MHEonline.com



Copyright © 2015 McGraw-Hill Education

All rights reserved. The contents, or parts thereof, may be reproduced in print form for non-profit educational use with *SRA Open Court Reading*, provided such reproductions bear copyright notice, but may not be reproduced in any form for any other purpose without the prior written consent of McGraw-Hill Education, including, but not limited to, network storage or transmission, or broadcast for distance learning.

Send all inquiries to:  
McGraw-Hill Education  
8787 Orion Place  
Columbus, OH 43240





Dad sat.

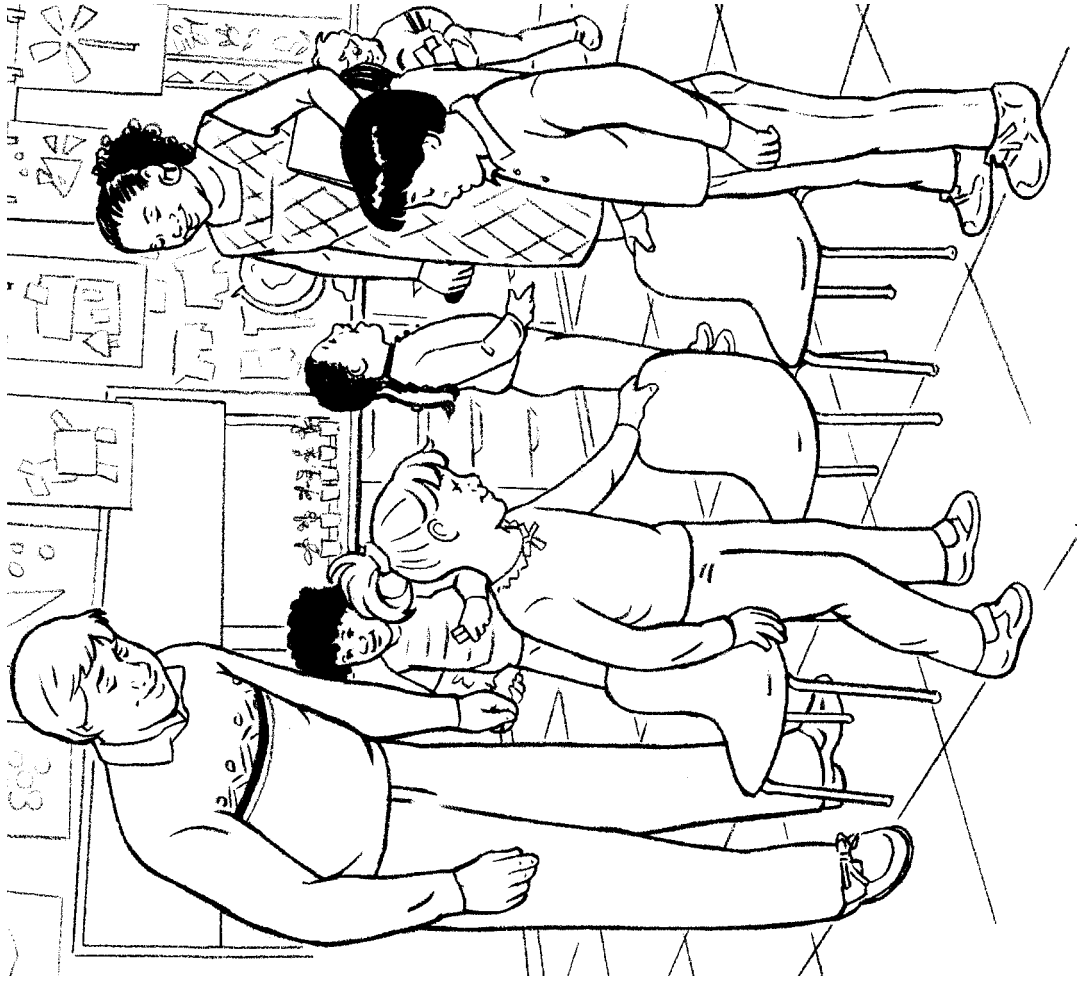

Tad, Tam, and Dad sat.

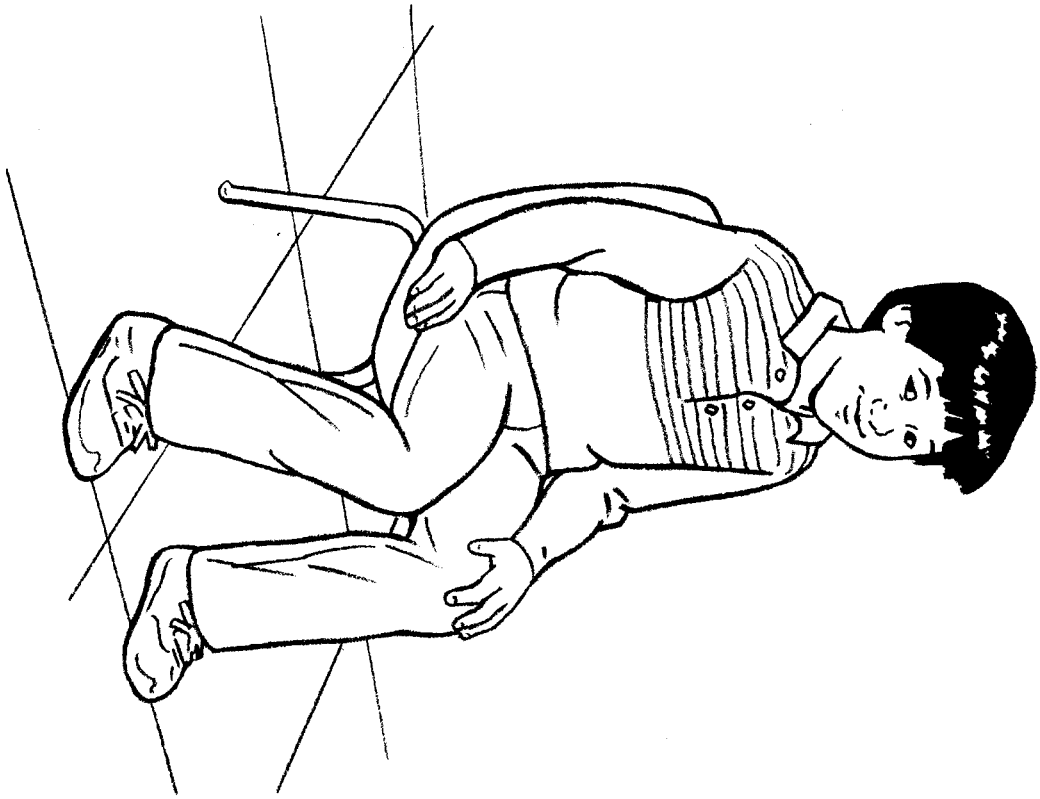

Tad sat.

4

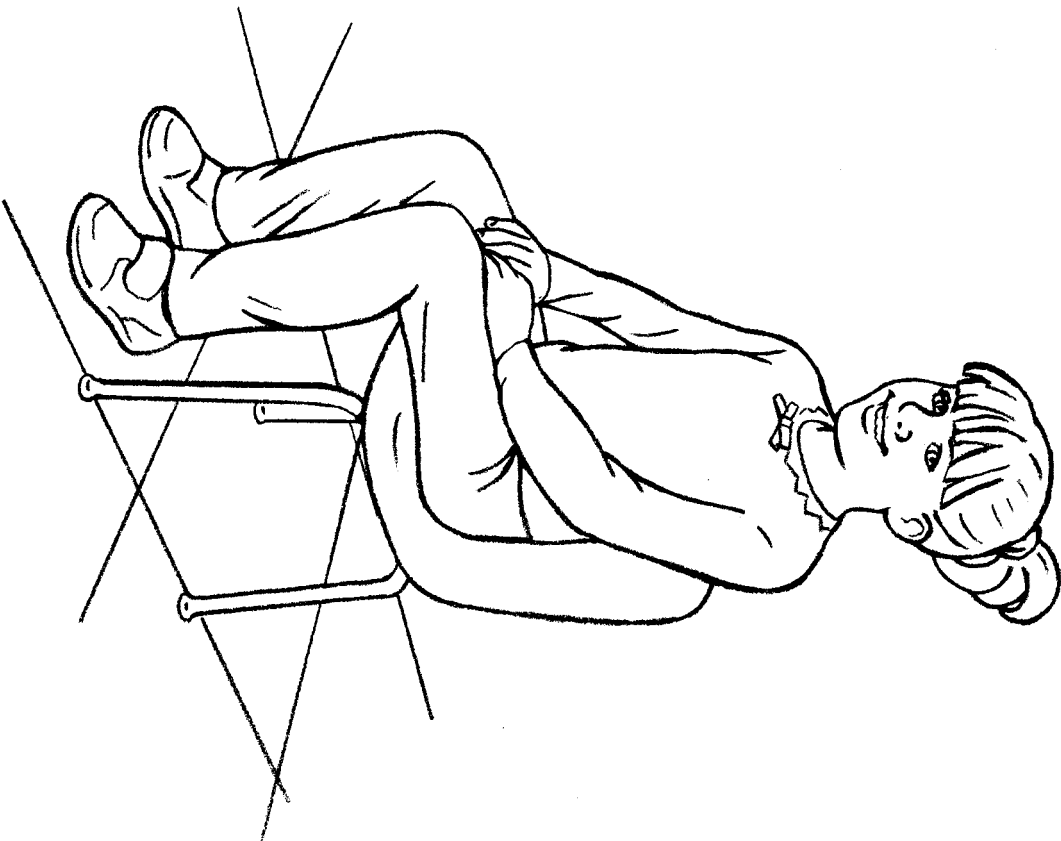

Tam sat.

5



Nan and Nat see ants!

# Ants

by Nancy Tyler  
illustrated by Steve Henry

Core Decodable 10



Bothell, WA • Chicago, IL • Columbus, OH • New York, NY

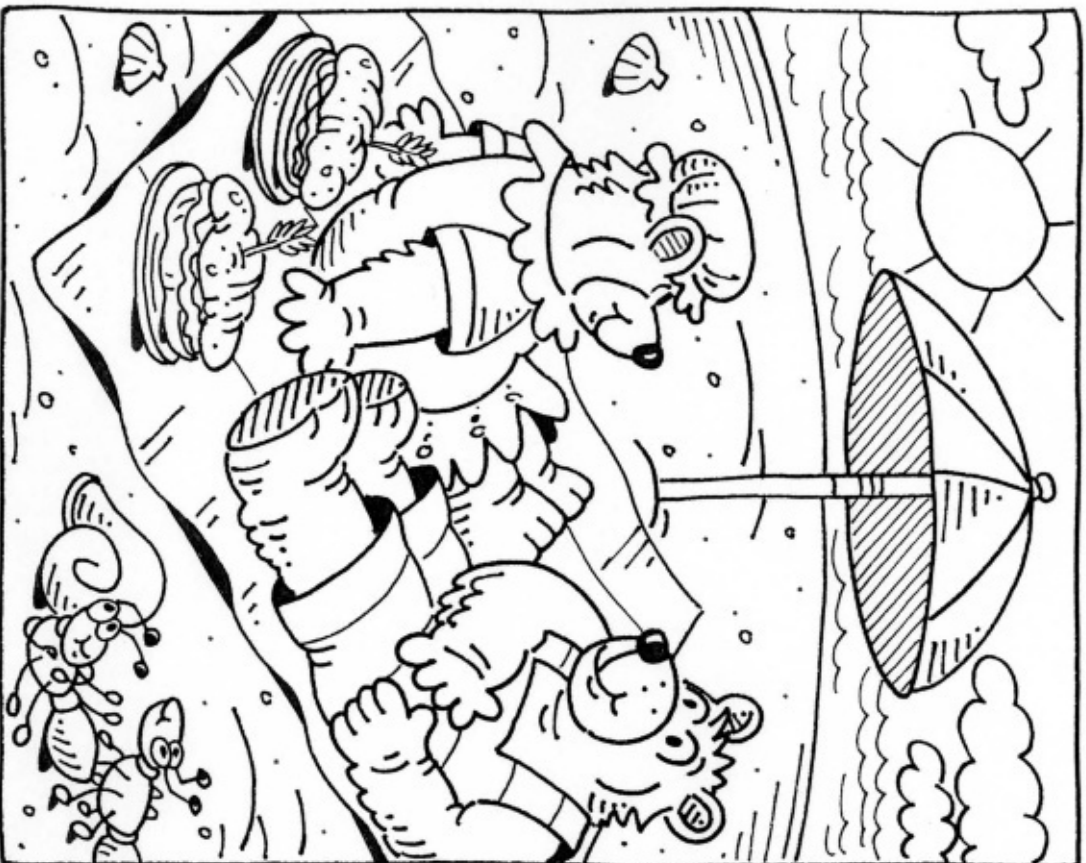

Nat and Nan sat.

MHEonline.com



Copyright © 2015 McGraw-Hill Education

All rights reserved. The contents, or parts thereof, may be reproduced in print form for non-profit educational use with *SRA Open Court Reading*, provided such reproductions bear copyright notice, but may not be reproduced in any form for any other purpose without the prior written consent of McGraw-Hill Education, including, but not limited to, network storage or transmission, or broadcast for distance learning.

Send all inquiries to:  
 McGraw-Hill Education  
 8787 Orion Place  
 Columbus, OH 43240



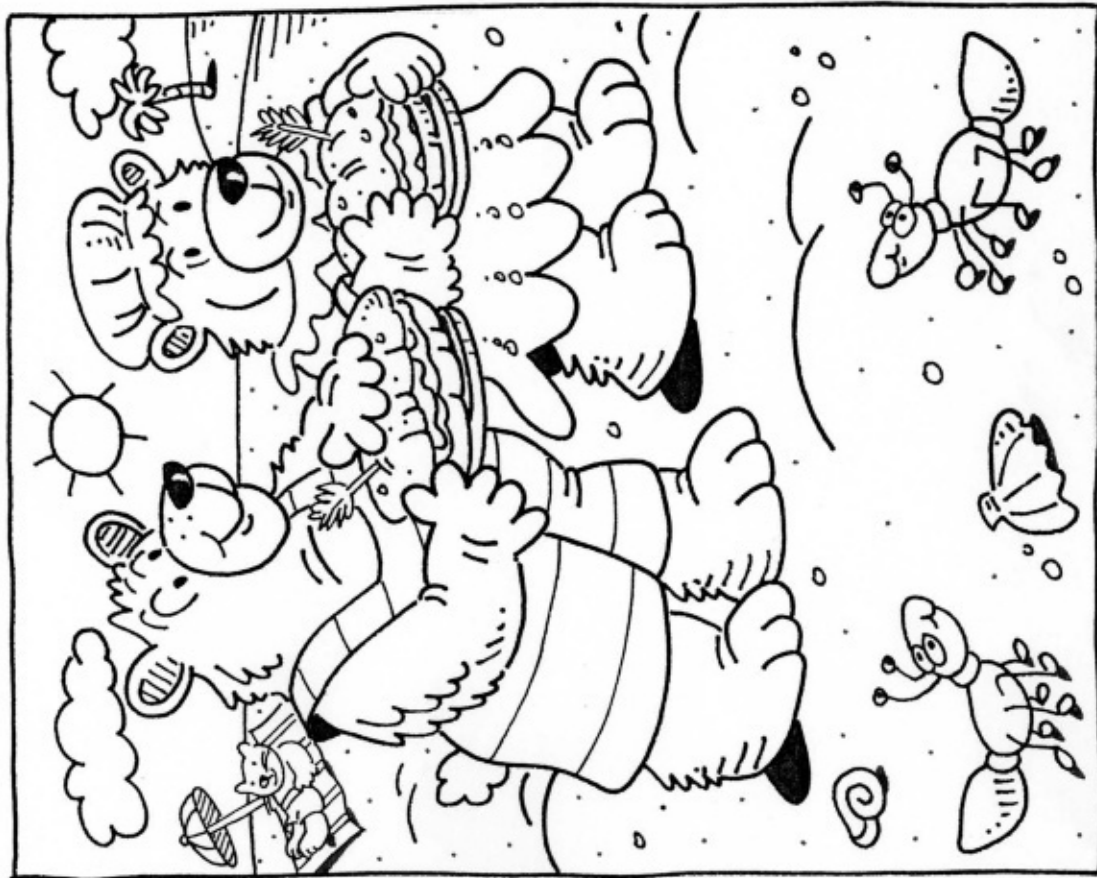

Ants see Nat and Nan.

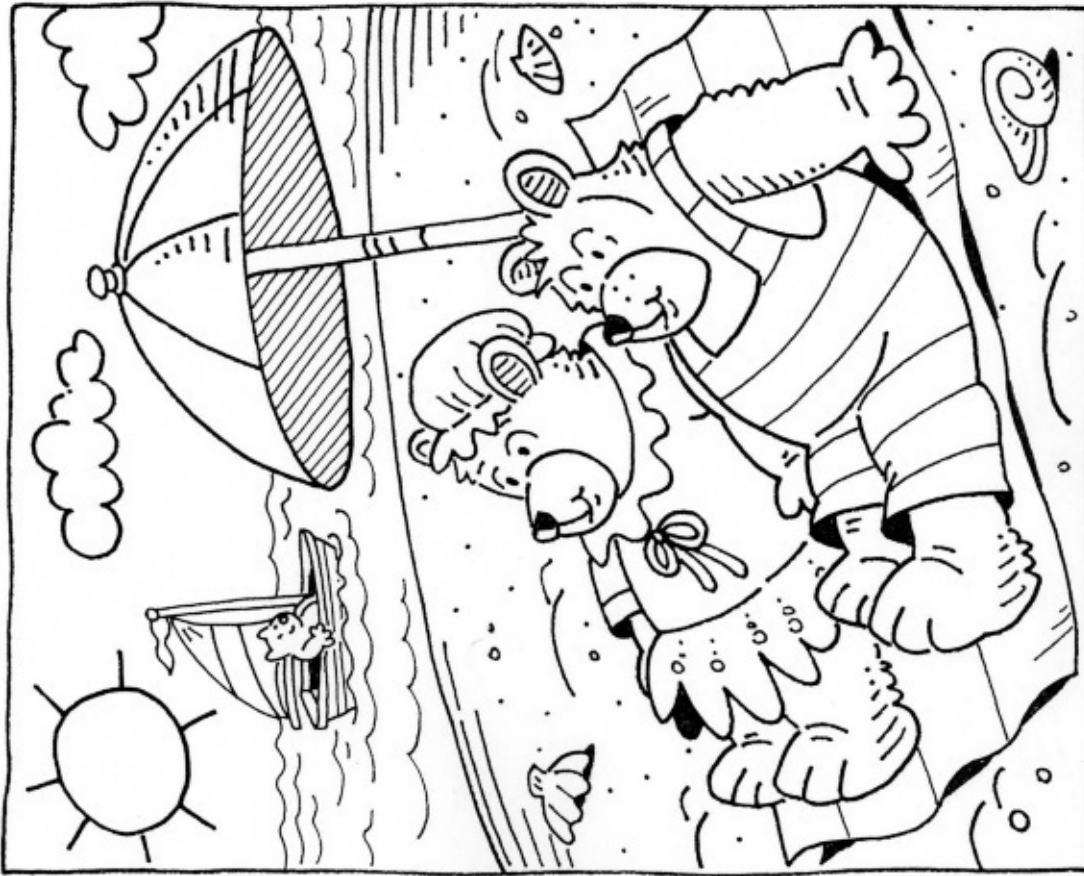

Nat and Nan sat.

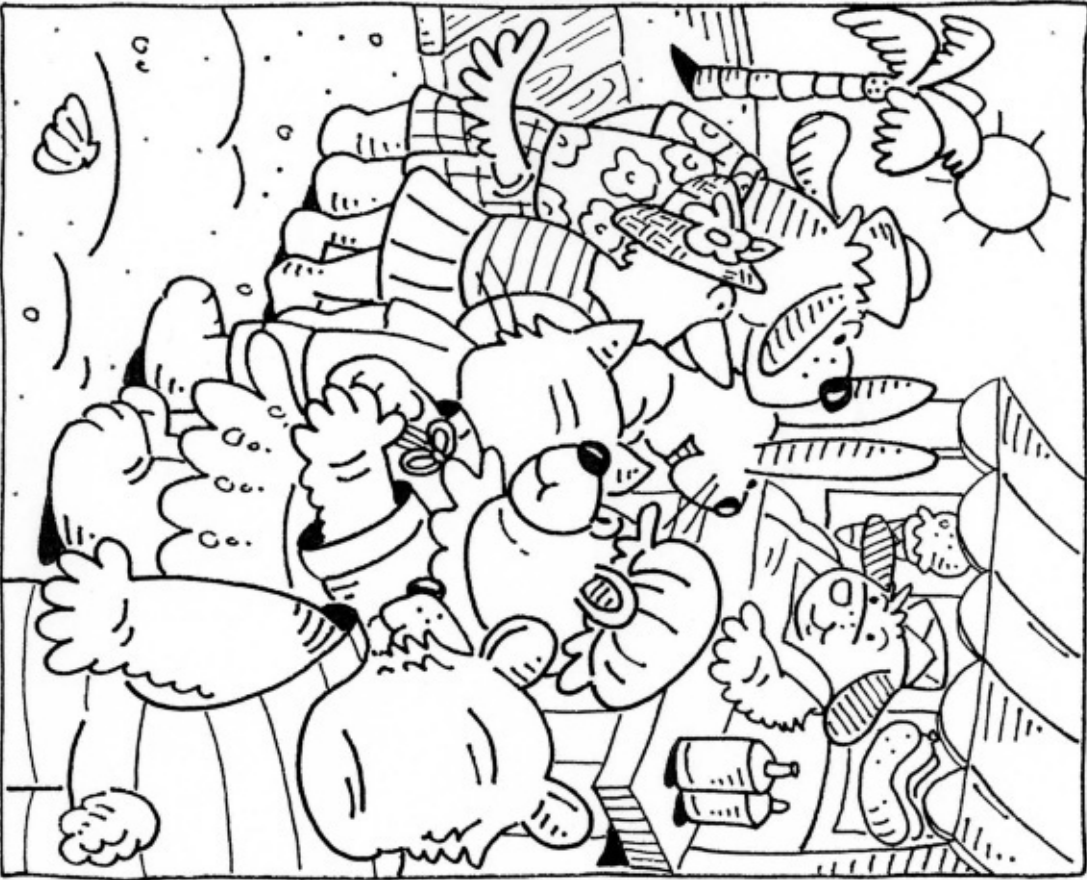

Nat and Nan stand.

4



Nat and Nan stand and stand.

5



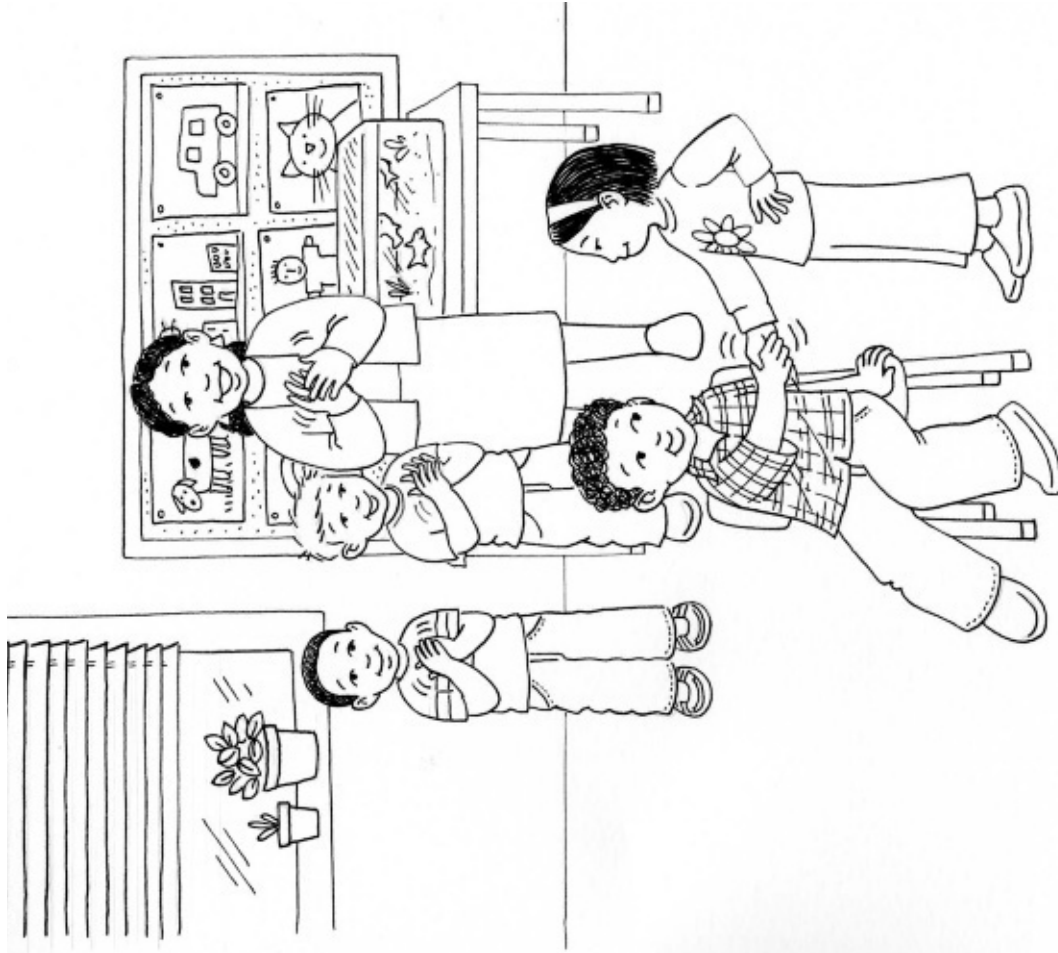

Sid did it! Sid sits.

# Sit

by Cecilia Winters  
illustrated by Kate Flanagan

Core Decodable II



Bothell, WA • Chicago, IL • Columbus, OH • New York, NY



Did Sid sit? Did Sis sit?

MHEonline.com



Copyright © 2015 McGraw-Hill Education

All rights reserved. The contents, or parts thereof, may be reproduced in print form for non-profit educational use with *SRA Open Court Reading*, provided such reproductions bear copyright notice, but may not be reproduced in any form for any other purpose without the prior written consent of McGraw-Hill Education, including, but not limited to, network storage or transmission, or broadcast for distance learning.

Send all inquiries to:  
McGraw-Hill Education  
8787 Orion Place  
Columbus, OH 43240

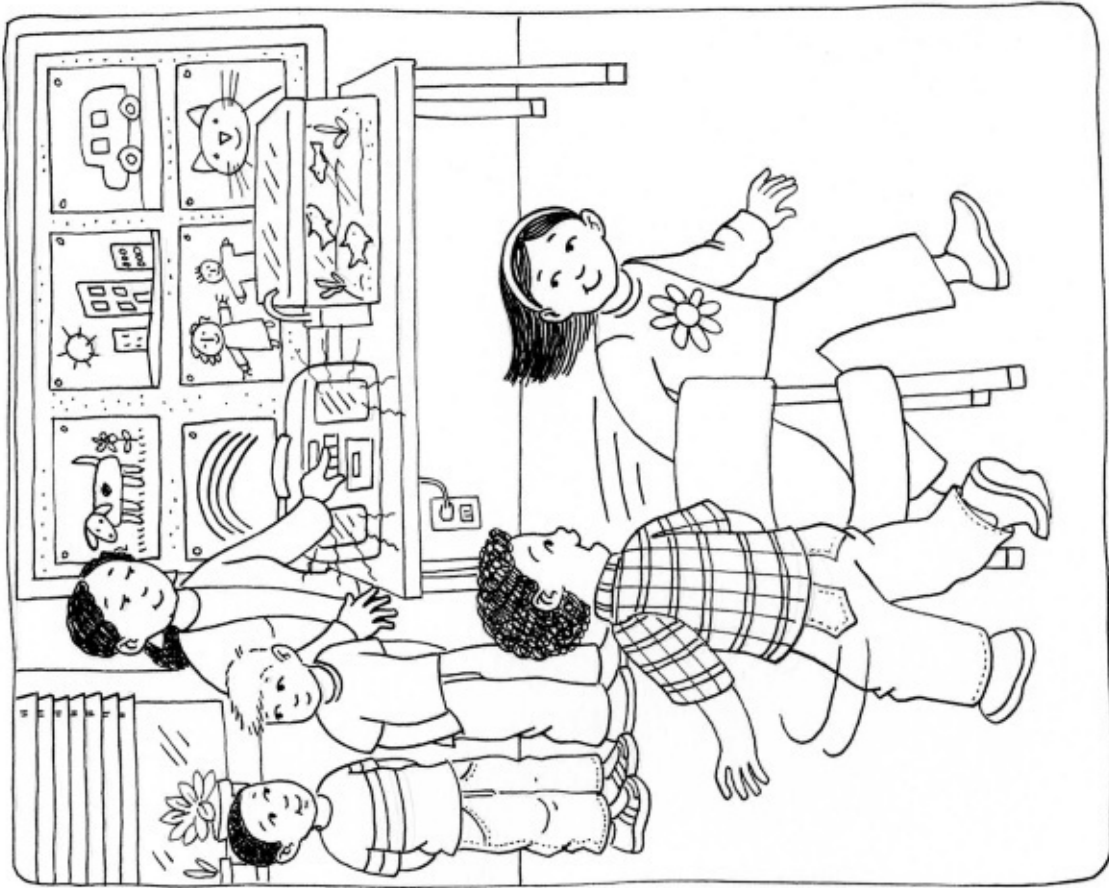

Did Tim sit? See Tim stand.

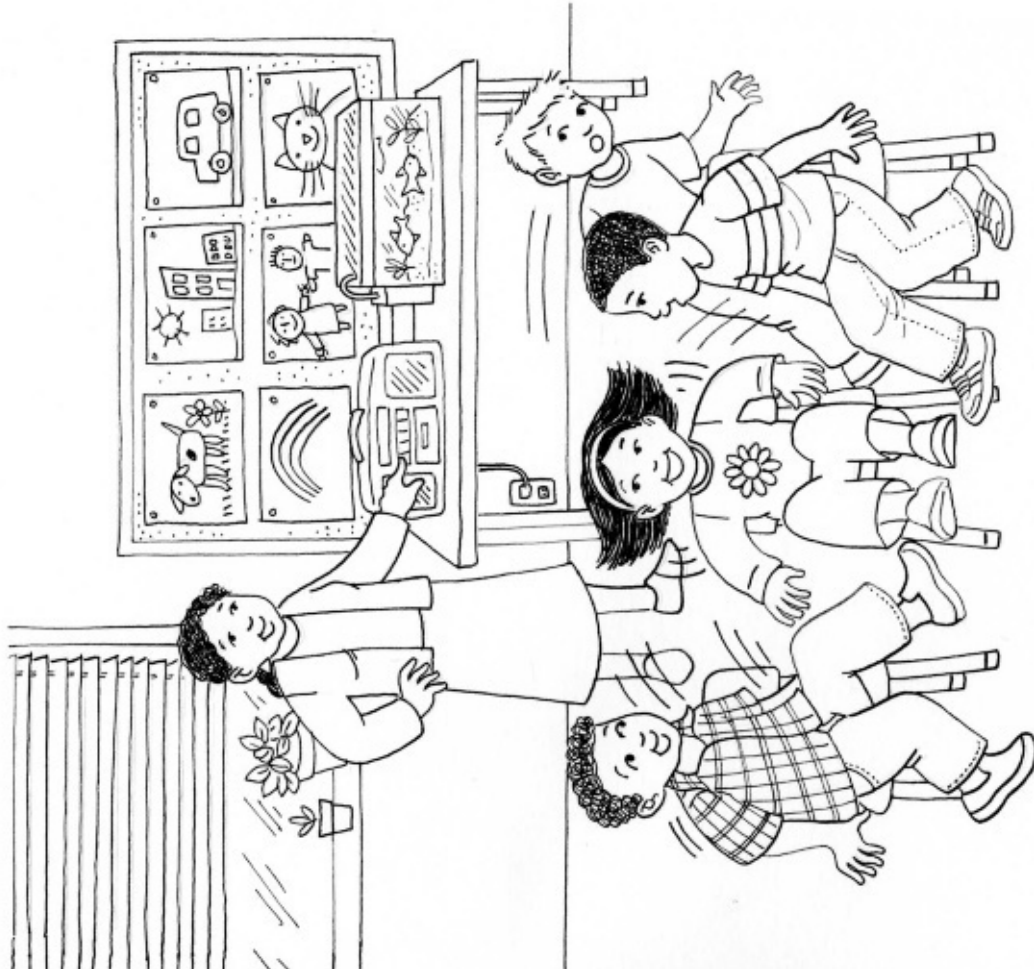

Sid, Sis, and Tim sit.





Did Matt sit? See Matt stand.

4



Sid and Sis sit.

5

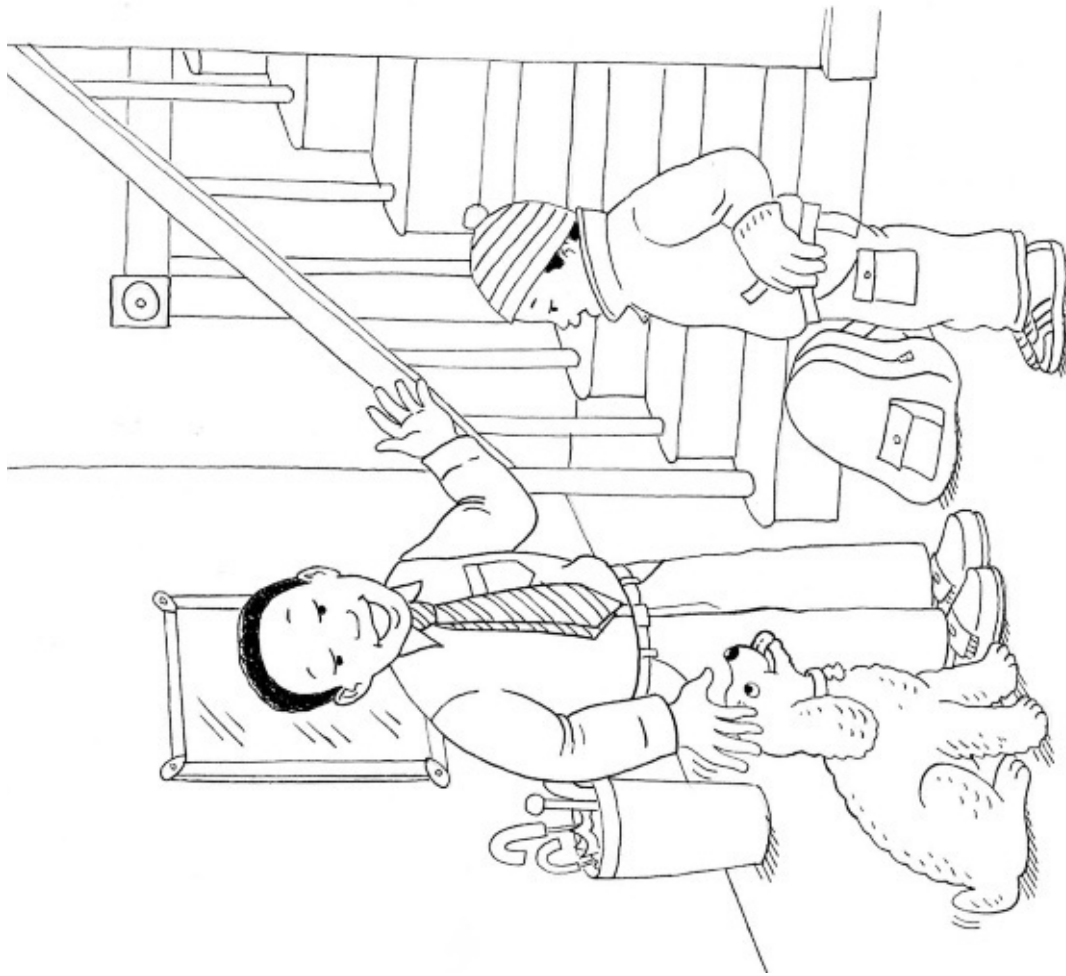

“Sid hid it!” said Dad.

# A Hint

by Sidney Allen  
illustrated by Kate Flanagan

Core Decodable 12



Bothell, WA • Chicago, IL • Columbus, OH • New York, NY

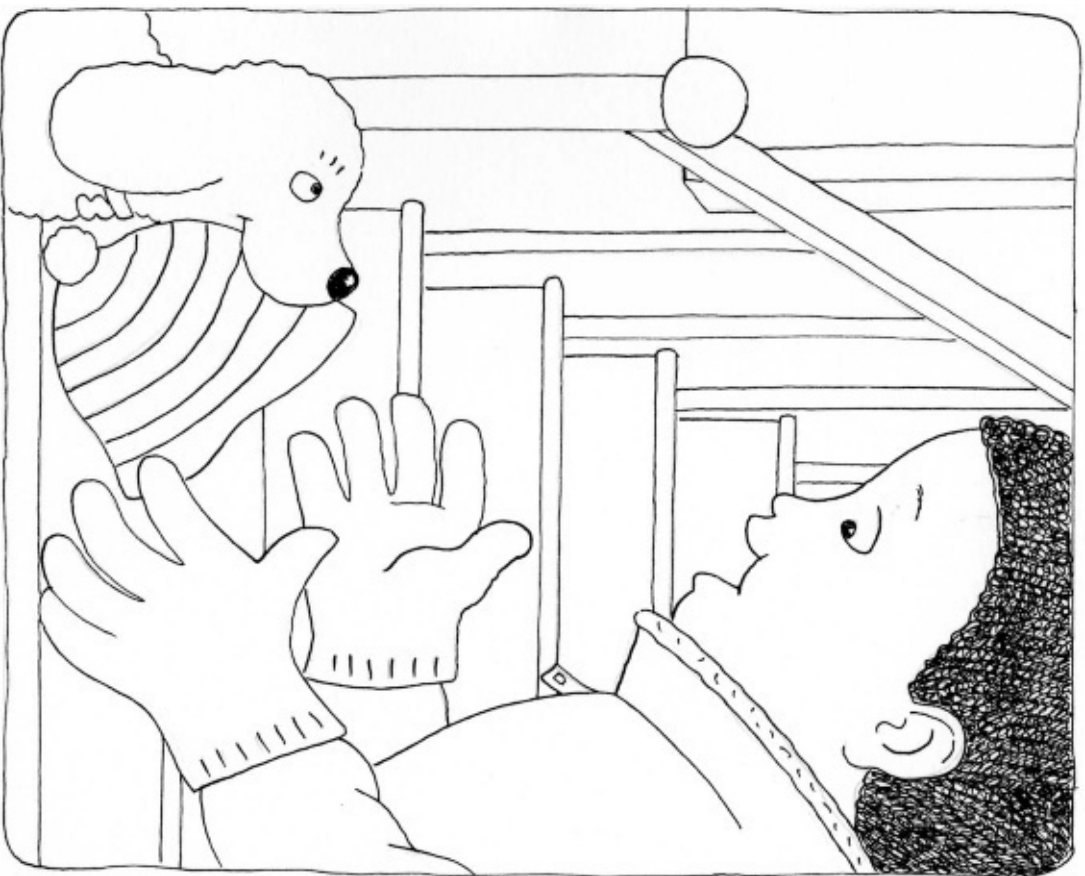

"A hat!" said Tim.

MHEonline.com



Copyright © 2015 McGraw-Hill Education

All rights reserved. The contents, or parts thereof, may be reproduced in print form for non-profit educational use with *SRA Open Court Reading*, provided such reproductions bear copyright notice, but may not be reproduced in any form for any other purpose without the prior written consent of McGraw-Hill Education, including, but not limited to, network storage or transmission, or broadcast for distance learning.

Send all inquiries to:  
McGraw-Hill Education  
8787 Orion Place  
Columbus, OH 43240



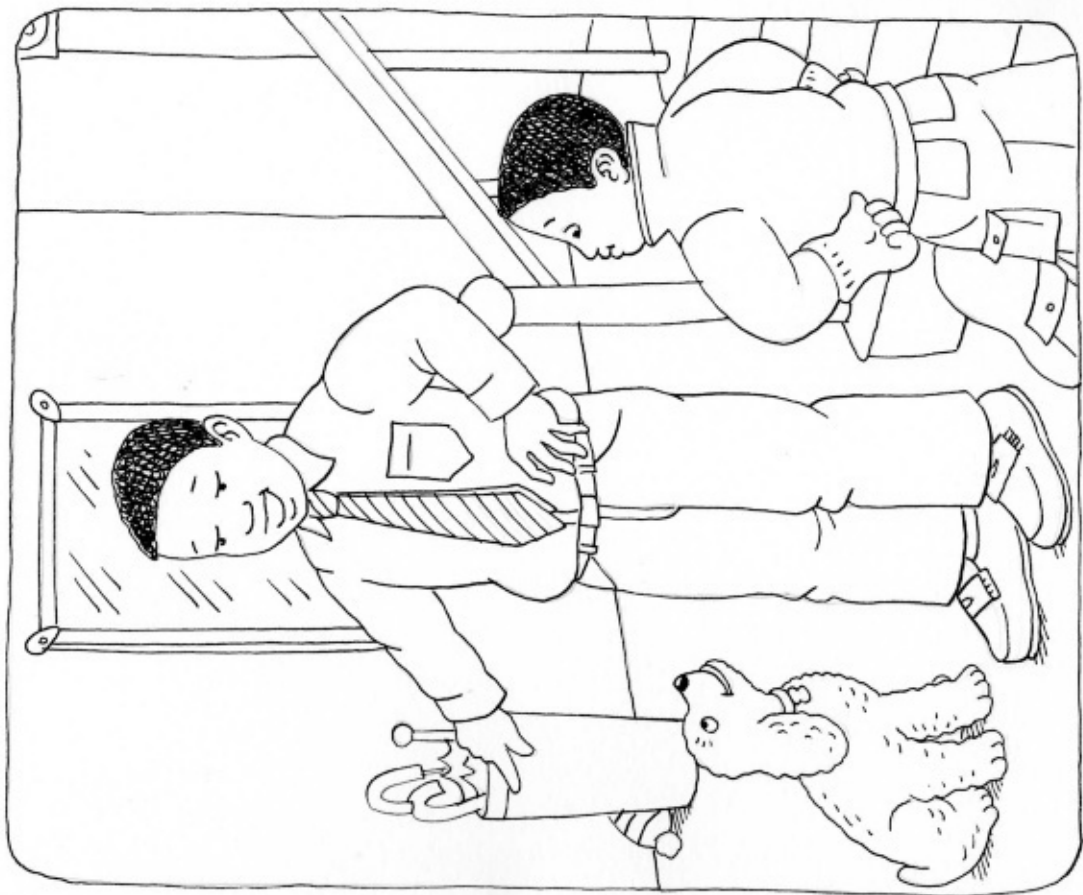

“Hand him a hat, Sid,” said Dad.

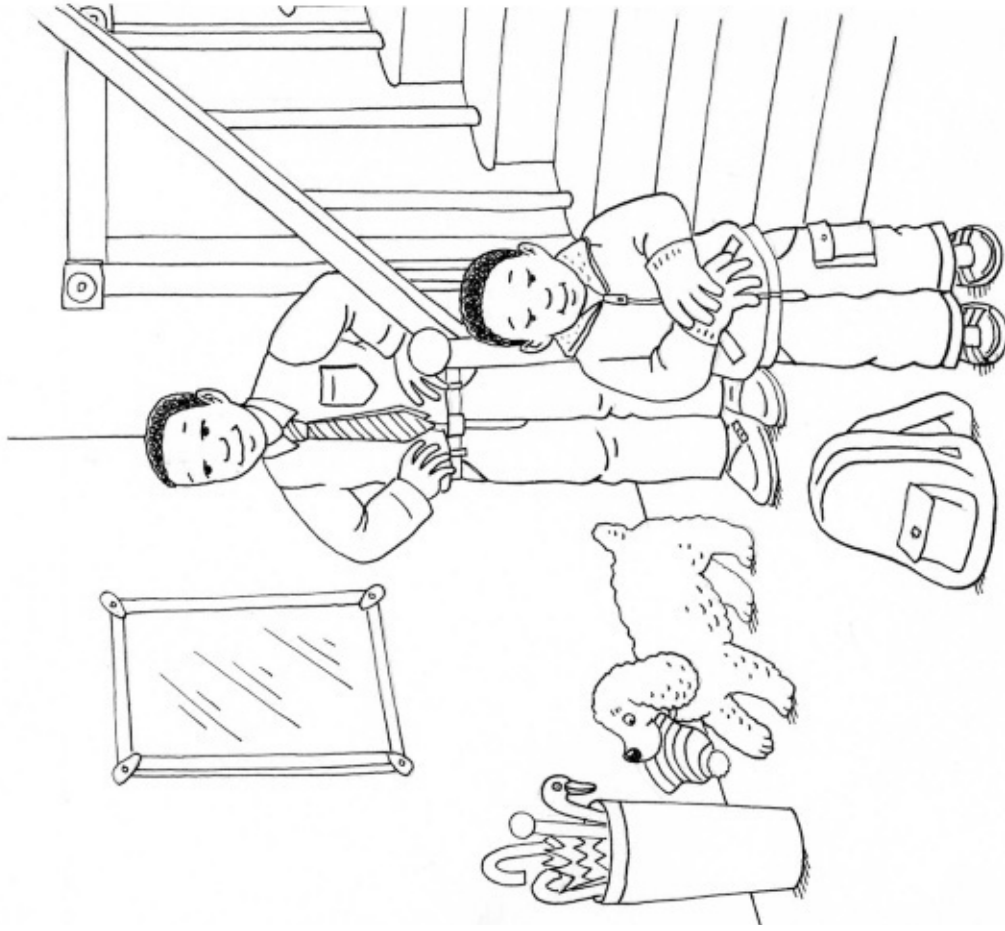

Sid hid a hat.

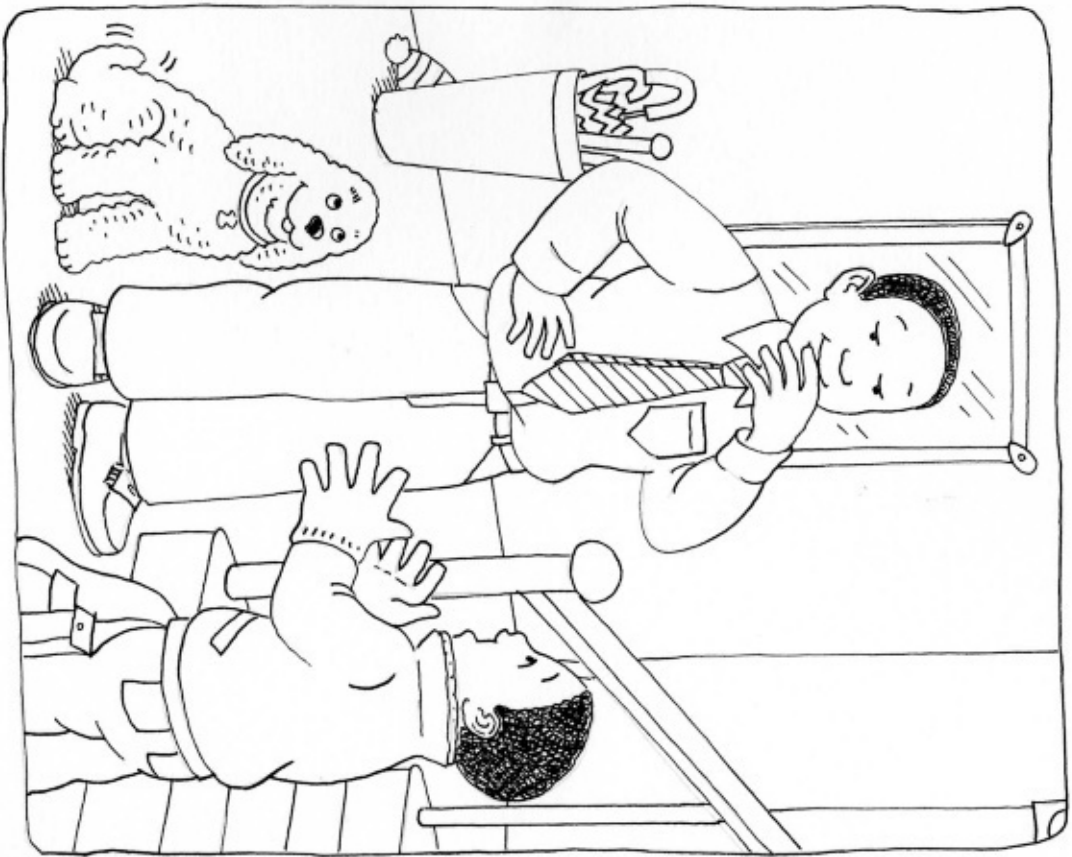

"I had a hat," said Tim.

4

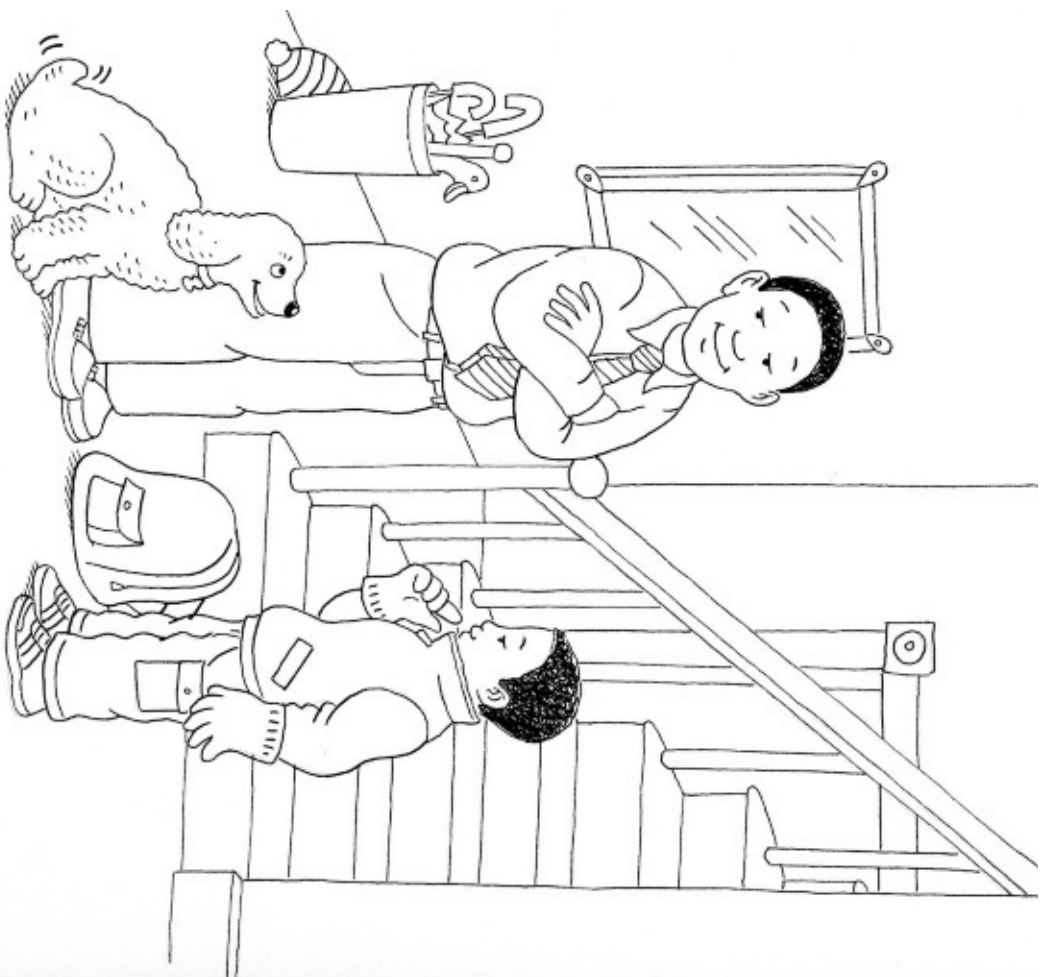

Dad had a hint.

5



Tam and Sid had a mint!

# Mints

by Tameron Dennis  
illustrated by Kate Flanagan

Core Decodable I3



Bothell, WA • Chicago, IL • Columbus, OH • New York, NY

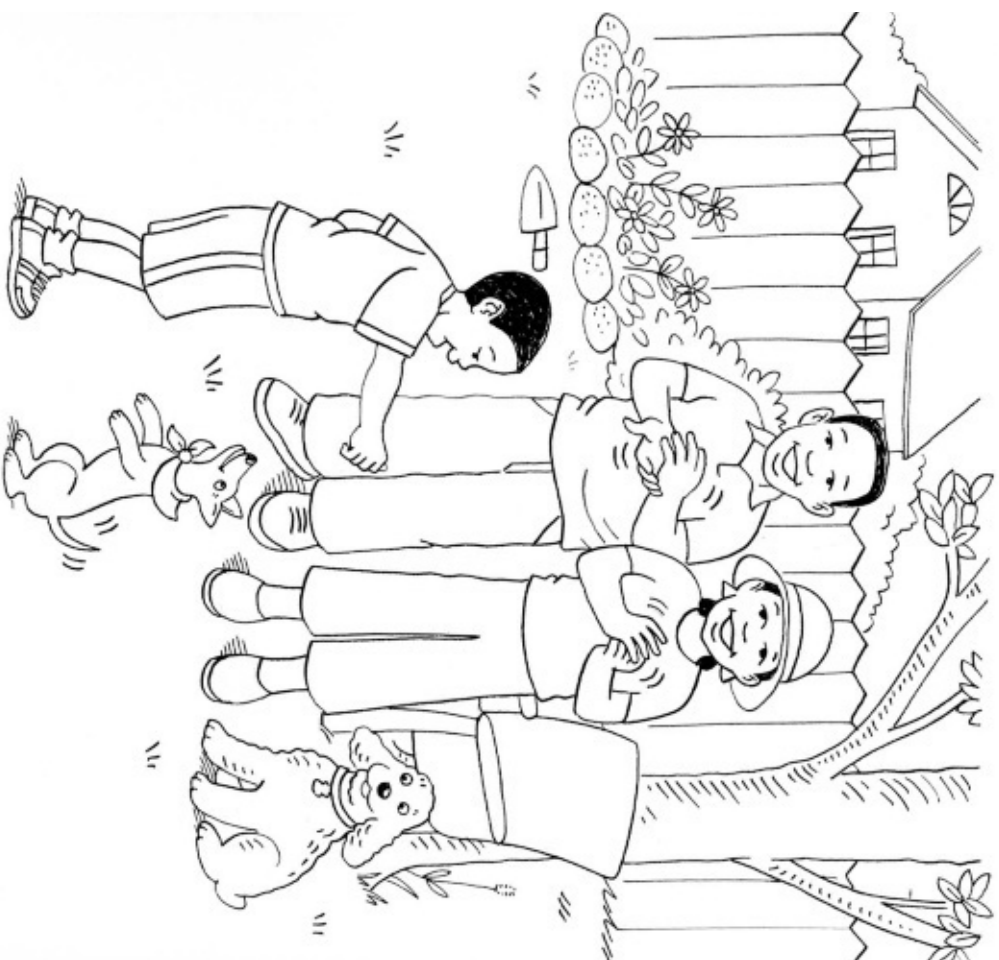

MHEonline.com



Copyright © 2015 McGraw-Hill Education

All rights reserved. The contents, or parts thereof, may be reproduced in print form for non-profit educational use with *SRA Open Court Reading*, provided such reproductions bear copyright notice, but may not be reproduced in any form for any other purpose without the prior written consent of McGraw-Hill Education, including, but not limited to, network storage or transmission, or broadcast for distance learning.

Send all inquiries to:  
McGraw-Hill Education  
8787 Orion Place  
Columbus, OH 43240

Tam did stand.



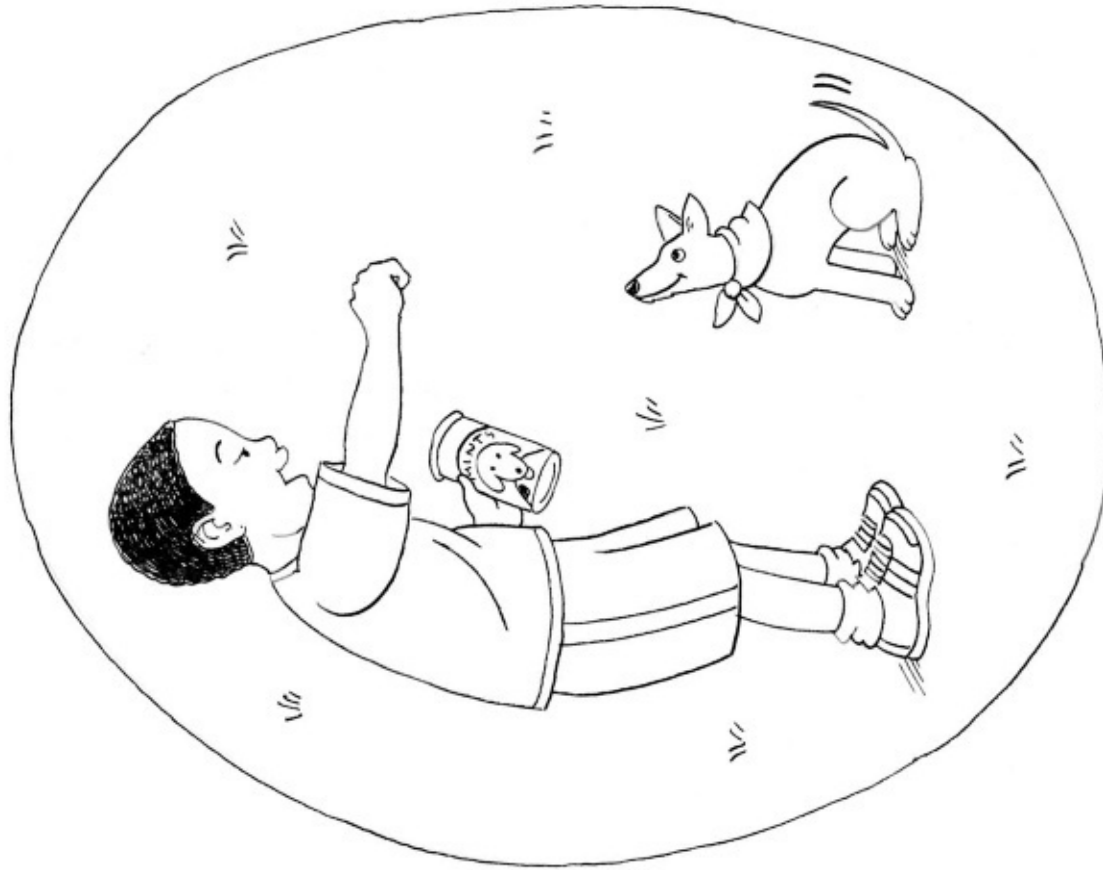

“Stand, Tam,” said Tim.



Tim had a tin can.

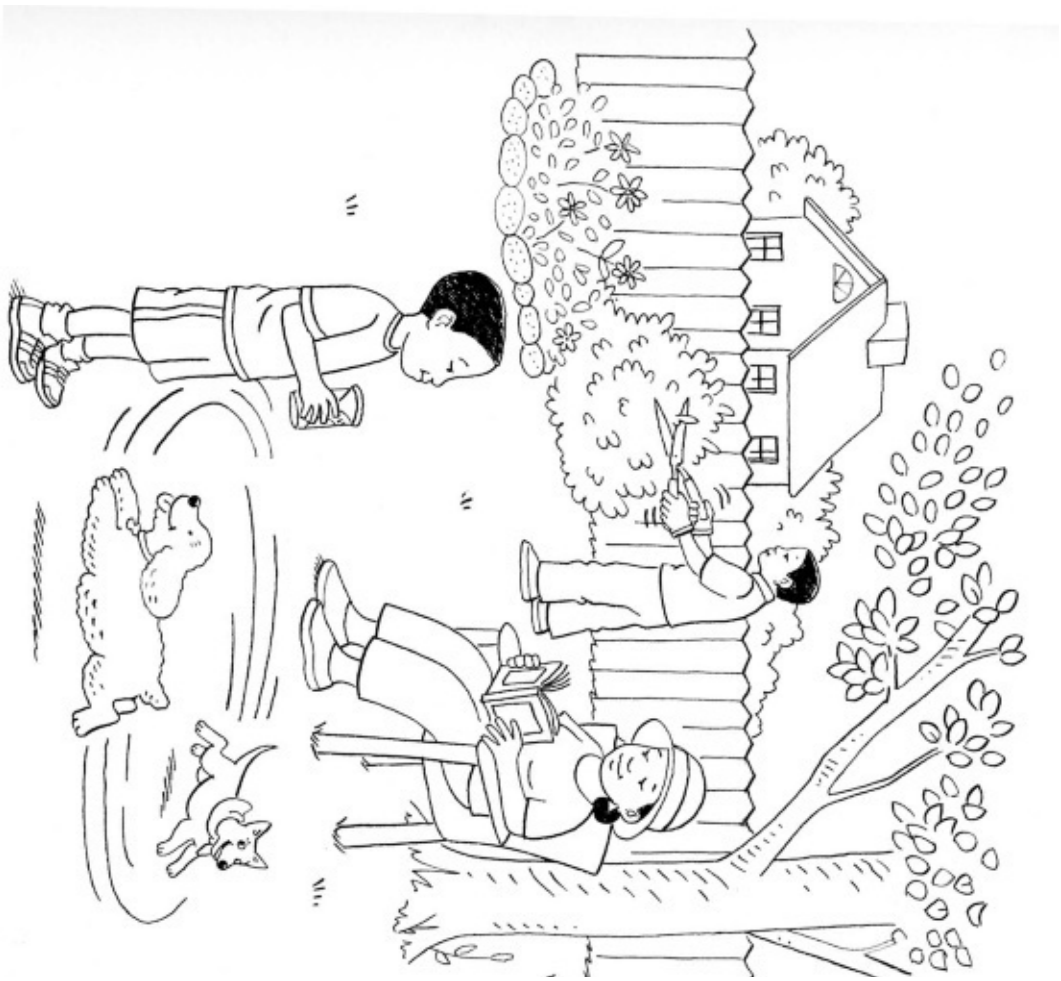

The tin can had mints in it.

4

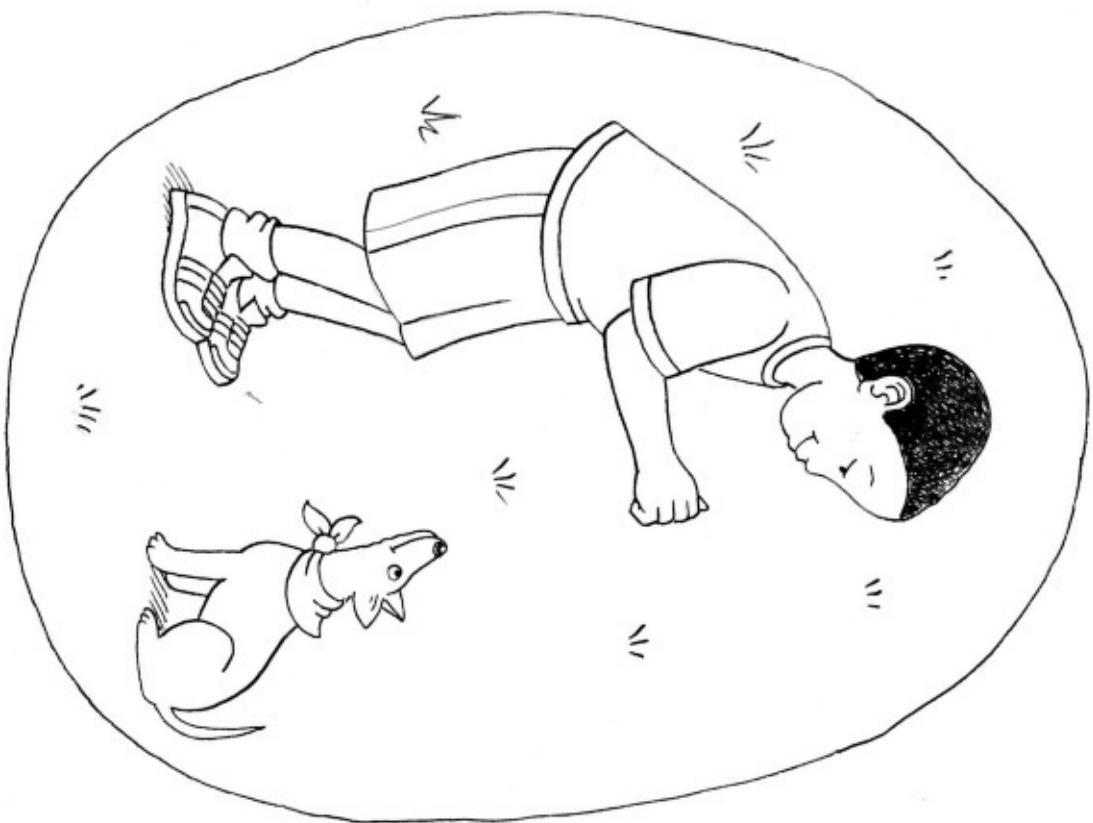

Did Tam see it?

13





Tim hid it in a hand.



Tim had a mint.

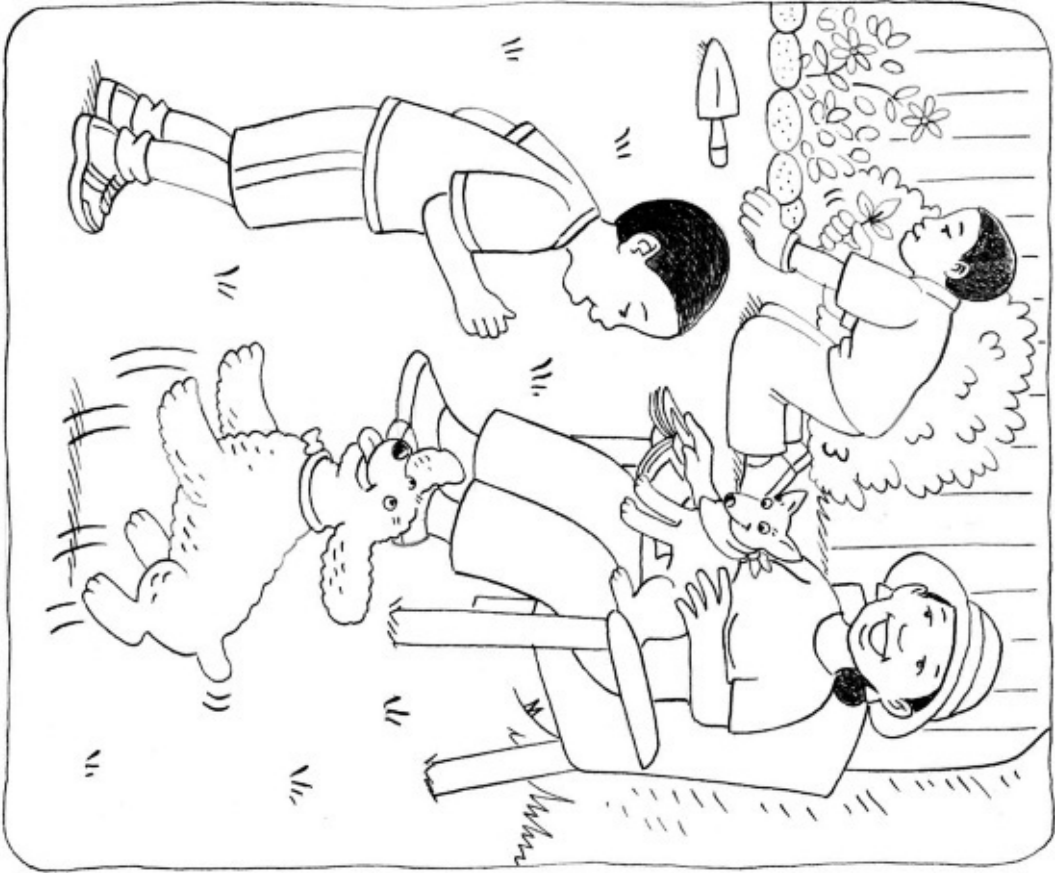

Tim hid it in a hand.

6



Tim had a mint.

11

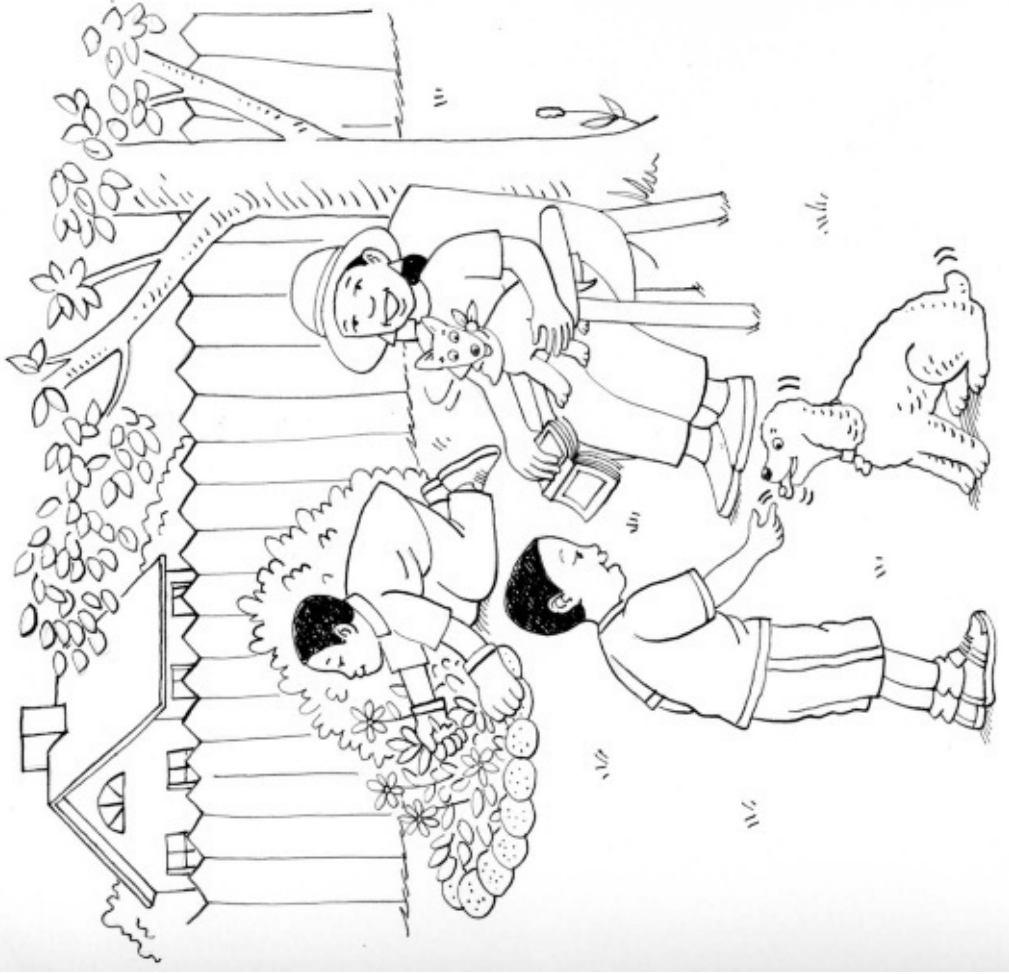

Sid had a mint!

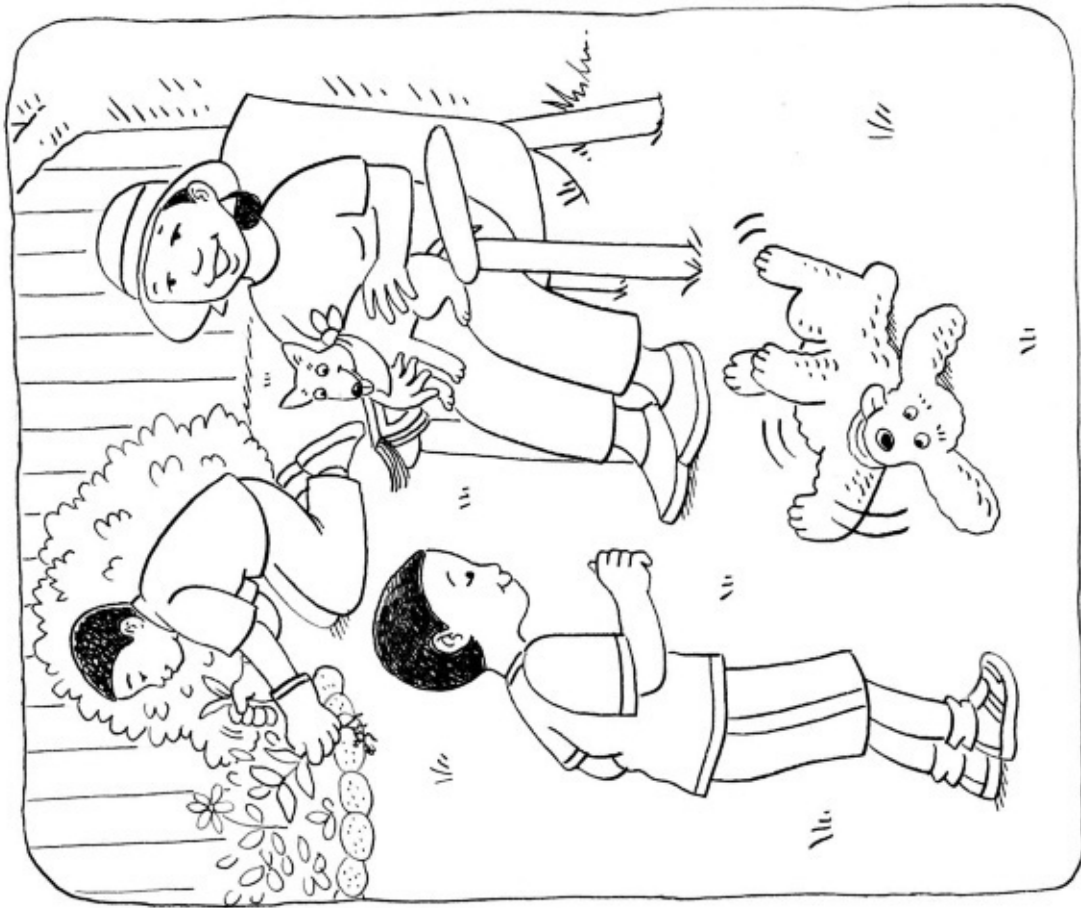

Did Sid see it?





"Sit, Sid," said Tim.



Sid sat.

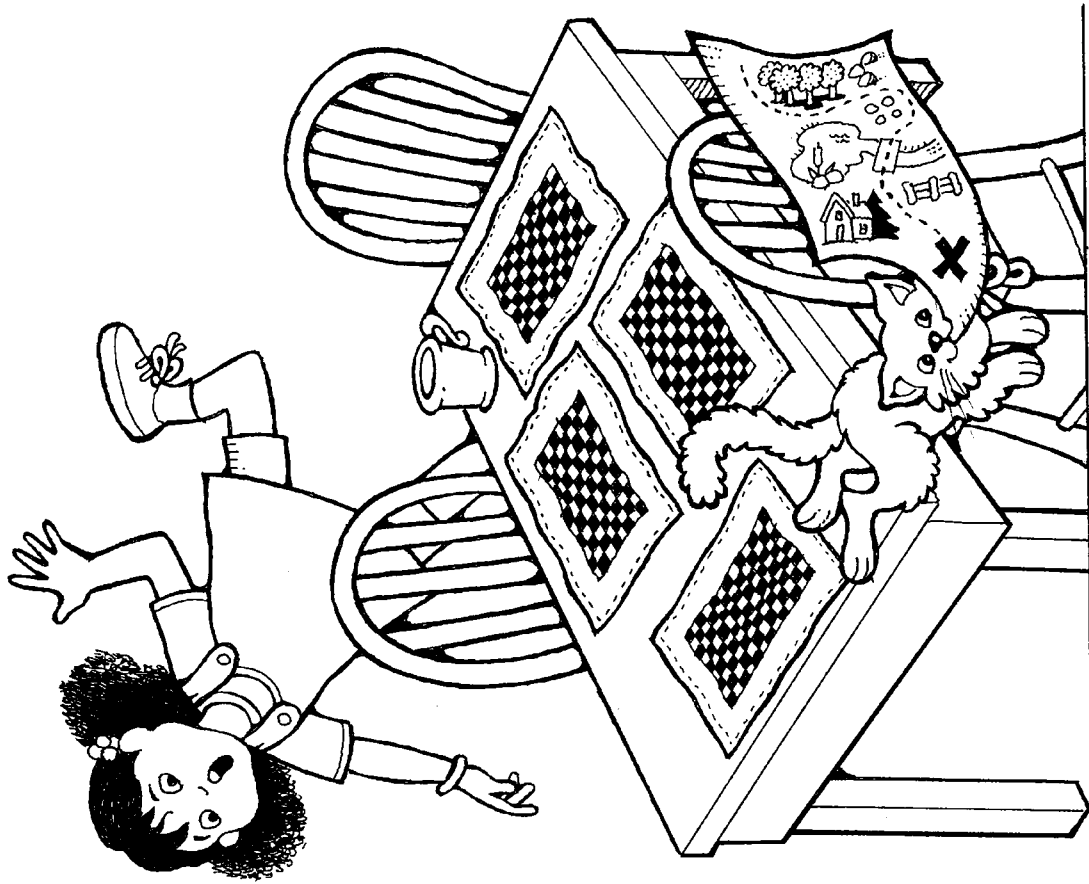

Sam nips Pat's map!

# Pat's Map

by Lucy Shepard  
illustrated by Olivia Cole

Core Decodable 14



Bothell, WA • Chicago, IL • Columbus, OH • New York, NY

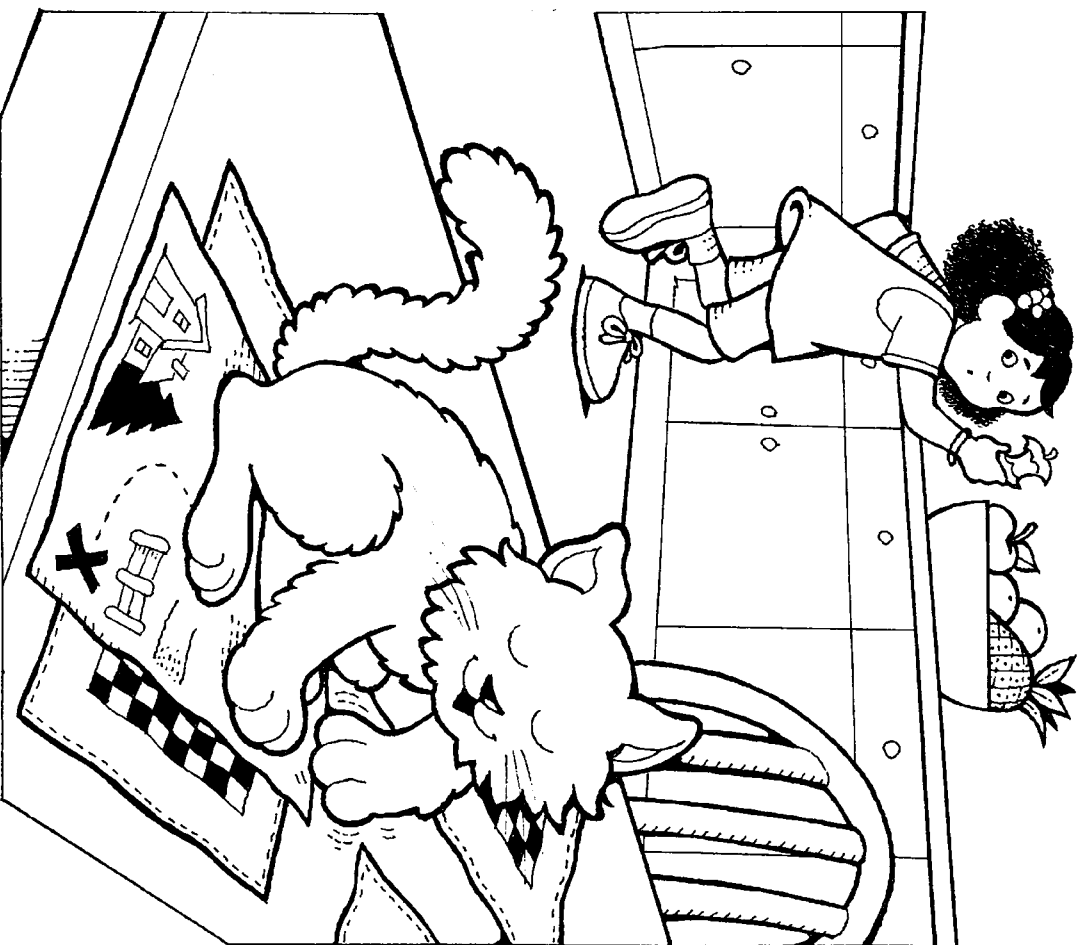

Sam hits Pat's map.

MHEonline.com



Copyright © 2015 McGraw-Hill Education

All rights reserved. The contents, or parts thereof, may be reproduced in print form for non-profit educational use with *SRA Open Court Reading*, provided such reproductions bear copyright notice, but may not be reproduced in any form for any other purpose without the prior written consent of McGraw-Hill Education, including, but not limited to, network storage or transmission, or broadcast for distance learning.

Send all inquiries to:  
 McGraw-Hill Education  
 8787 Orion Place  
 Columbus, OH 43240



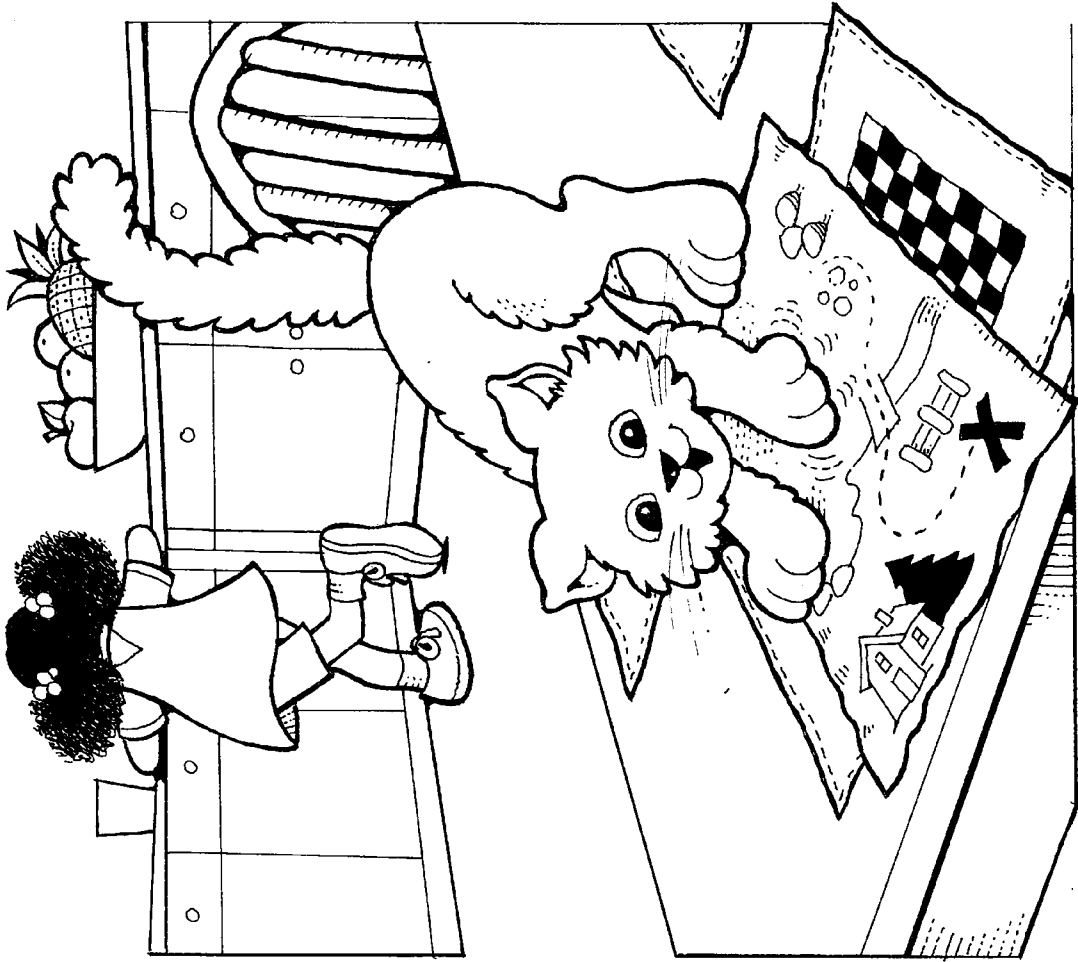

Sam taps Pat's map.

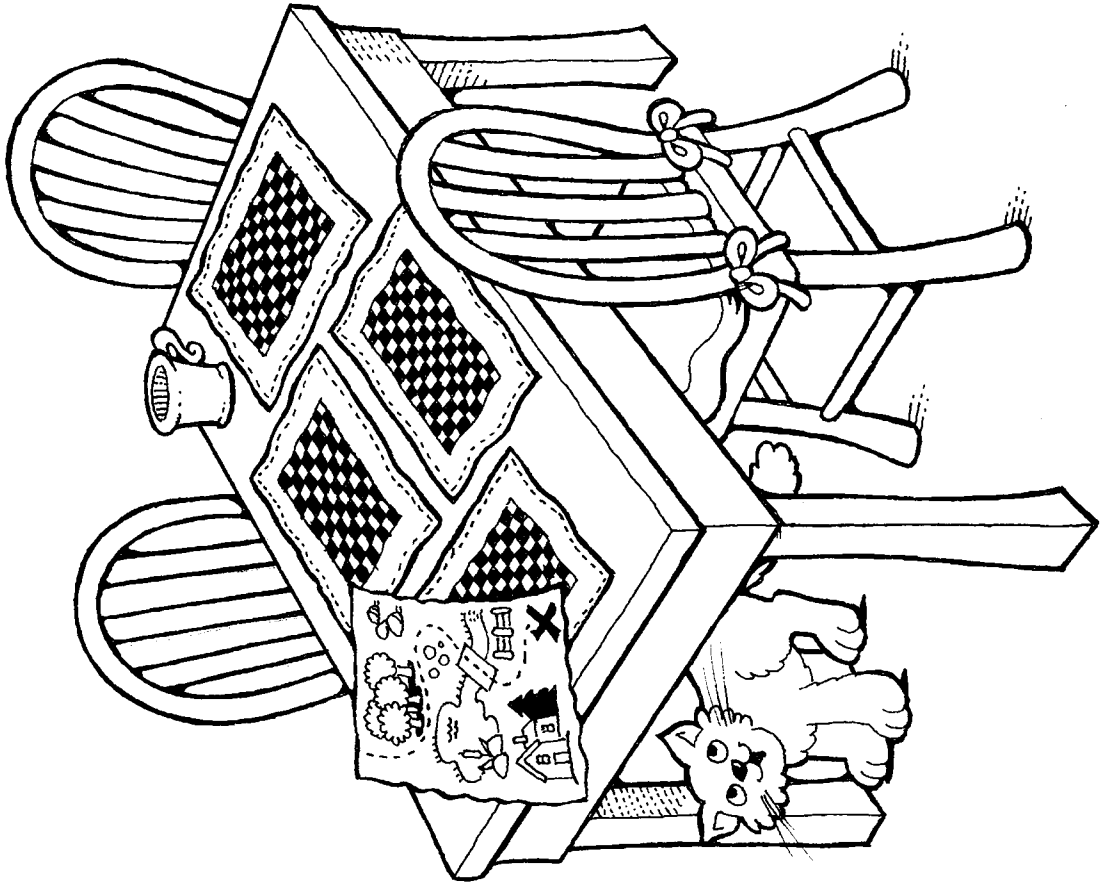

Pat's map sits on a mat.

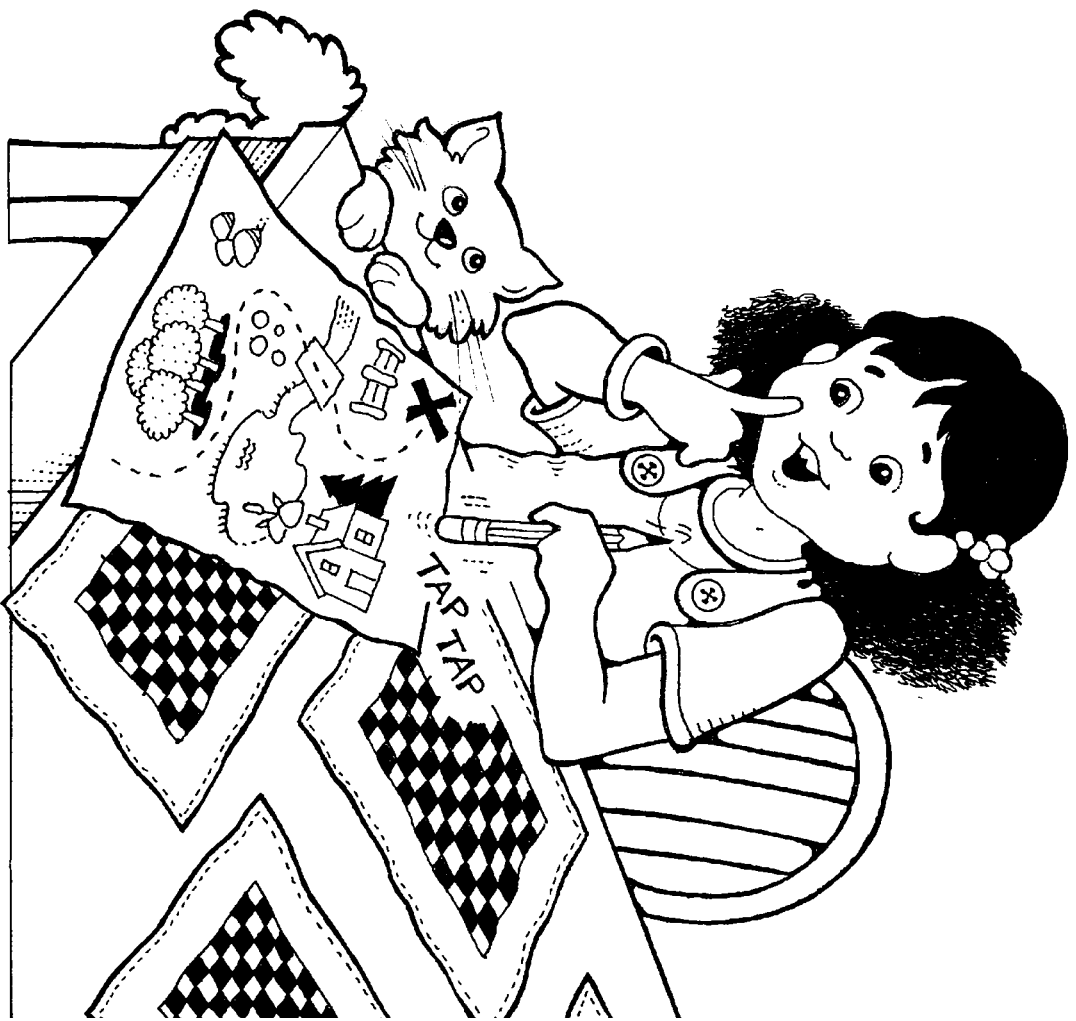

Pat taps the map.

4

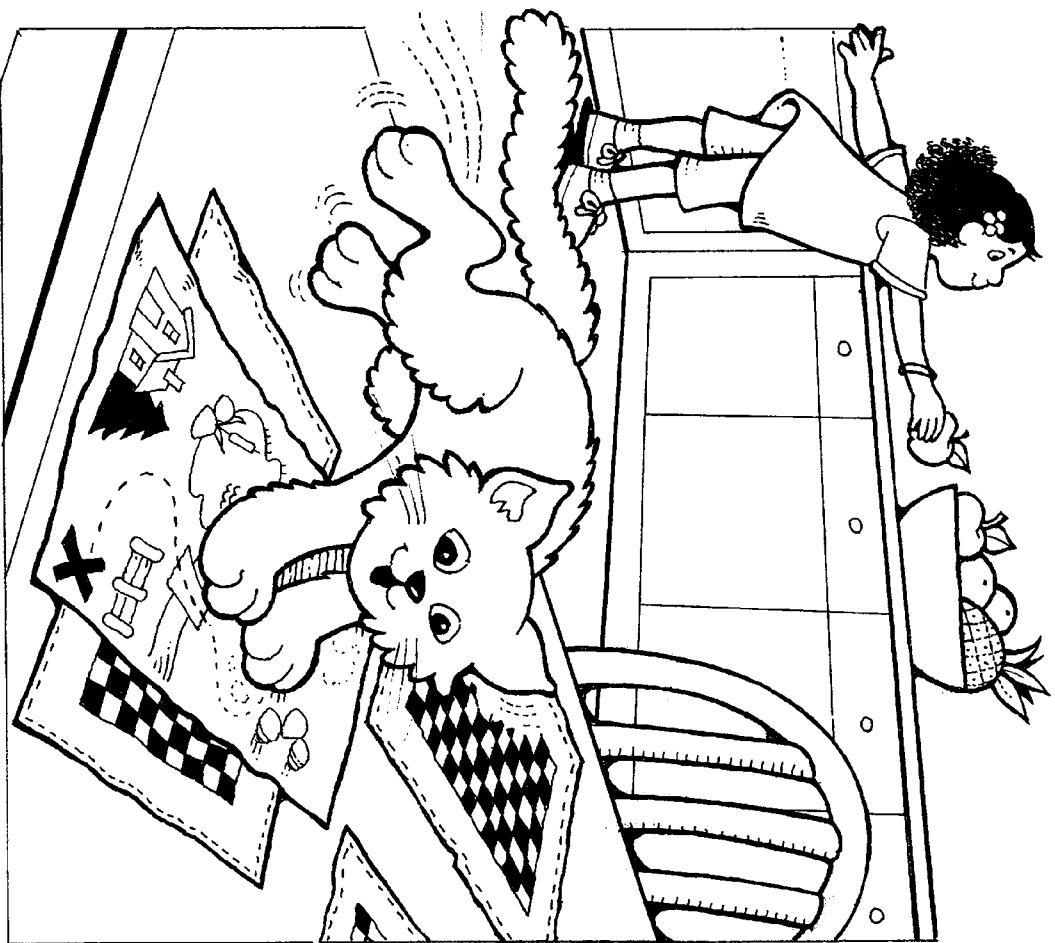

Sam stamps on Pat's map.

5

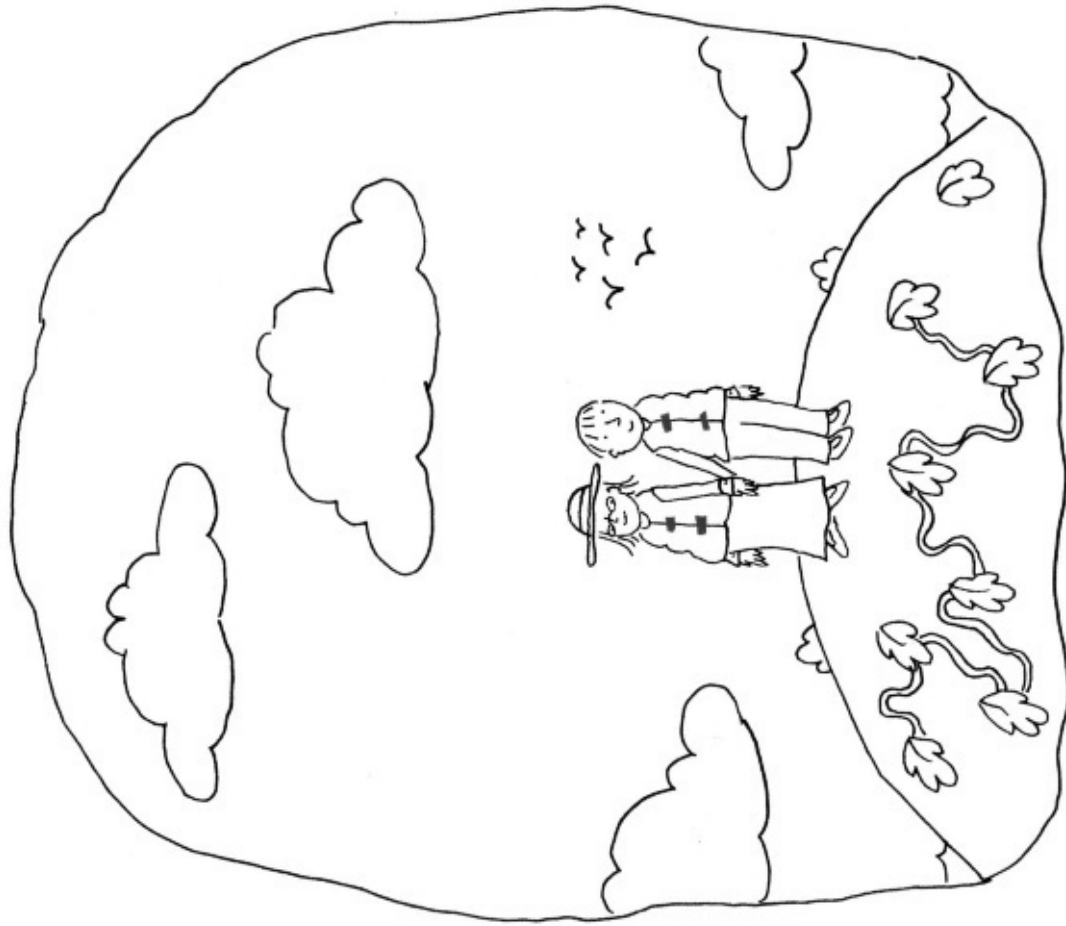

Lin and Hal stand still.

# Lin and Hal

by Linda Johnson  
illustrated by Paige Keiser

Core Decodable 15



Bothell, WA • Chicago, IL • Columbus, OH • New York, NY



Hal slips on plants.

MHEonline.com



Copyright © 2015 McGraw-Hill Education

All rights reserved. The contents, or parts thereof, may be reproduced in print form for non-profit educational use with SRA Open Court Reading, provided such reproductions bear copyright notice, but may not be reproduced in any form for any other purpose without the prior written consent of McGraw-Hill Education, including, but not limited to, network storage or transmission, or broadcast for distance learning.

Send all inquiries to:  
McGraw-Hill Education  
8787 Orion Place  
Columbus, OH 43240

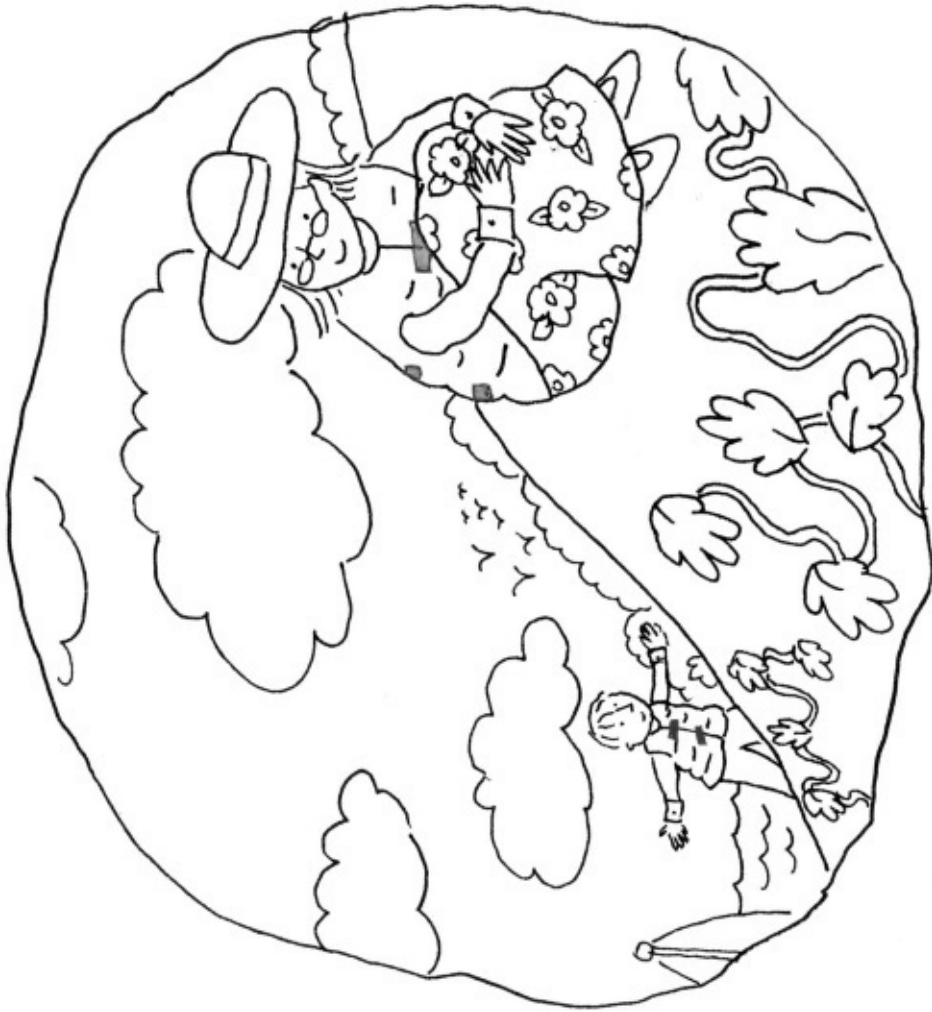

Lin sits on a hill.

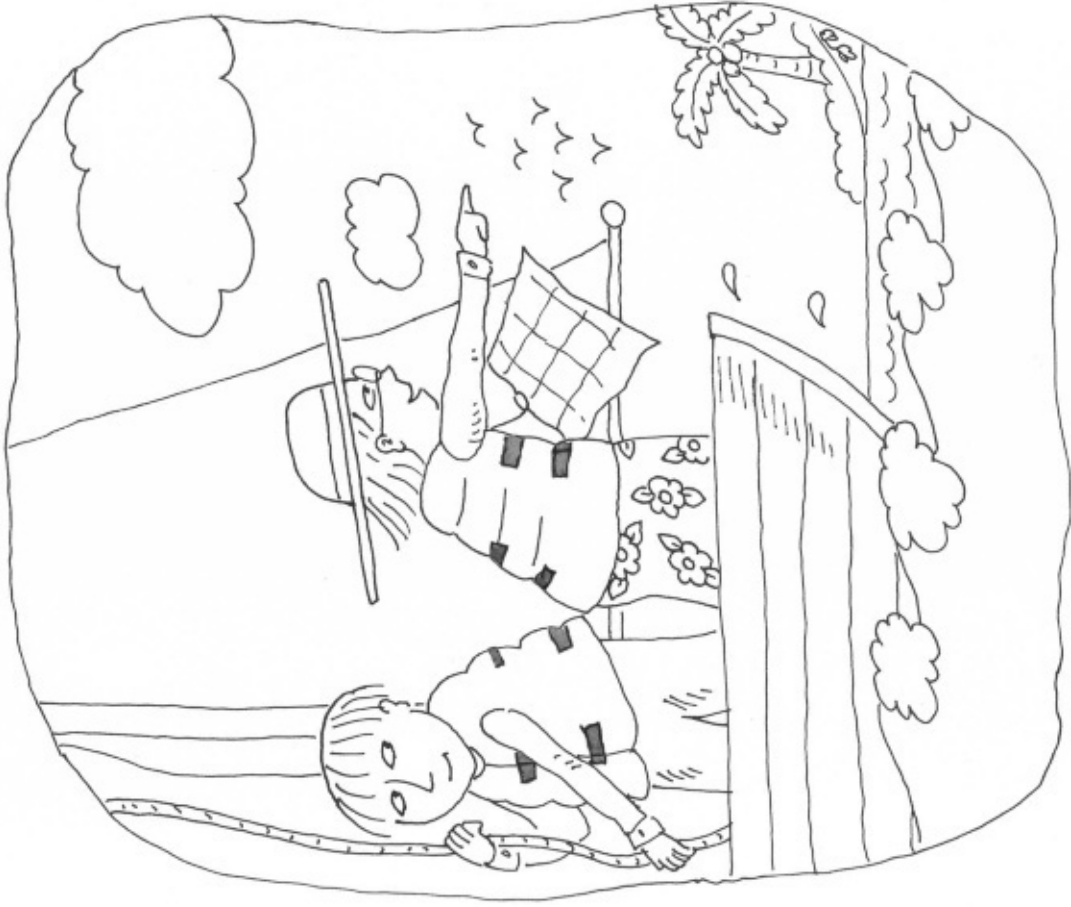

Lin had a plan.



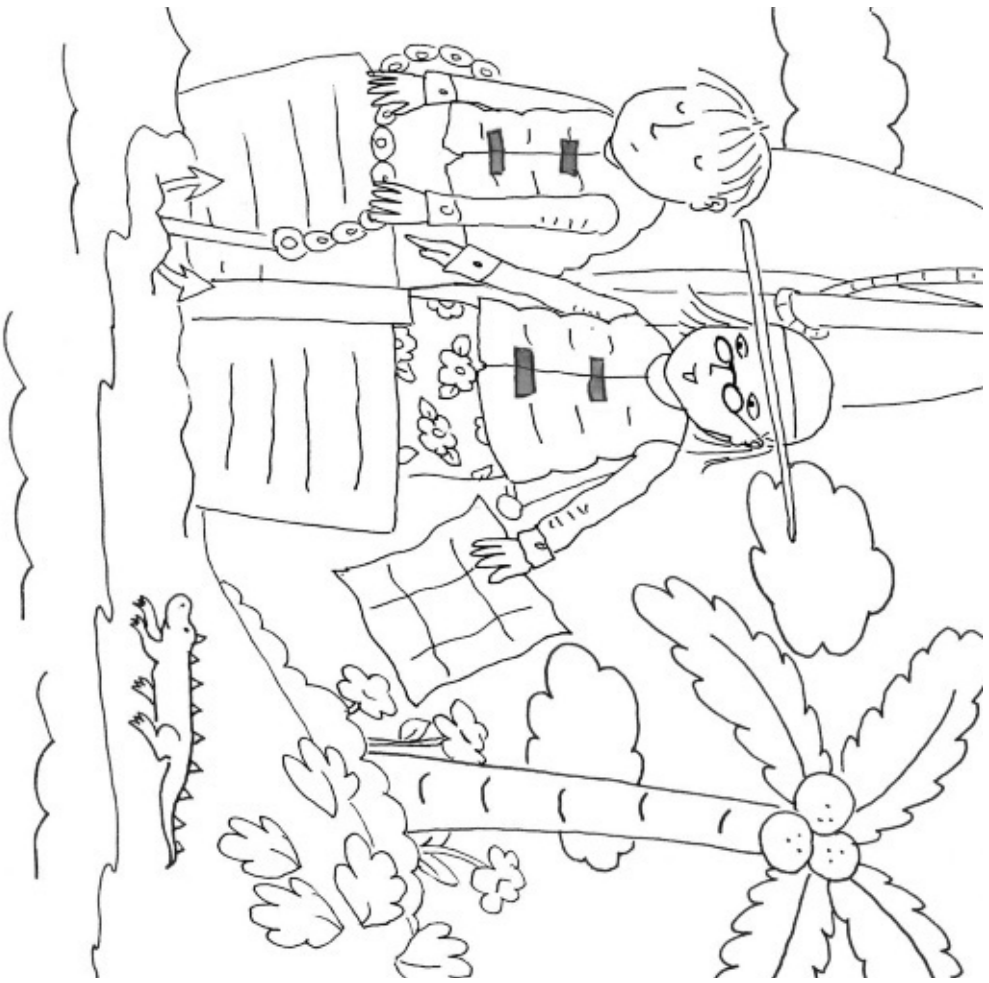

Hai can land in sand.

4



Lin slips in the sand.

5

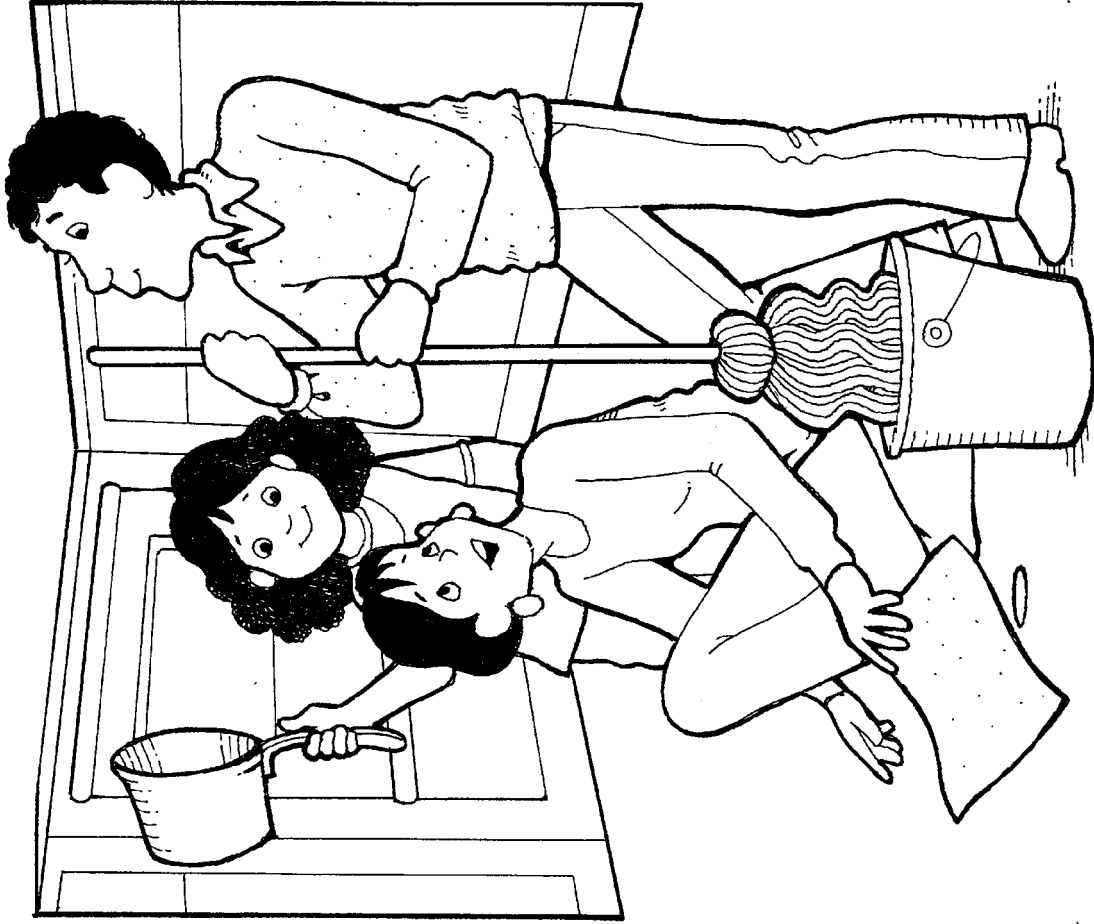

Mom pats a spot.

# A Spot

by Lucy Shepard  
illustrated by Olivia Cole

Core Decodable 16



Bothell, WA • Chicago, IL • Columbus, OH • New York, NY

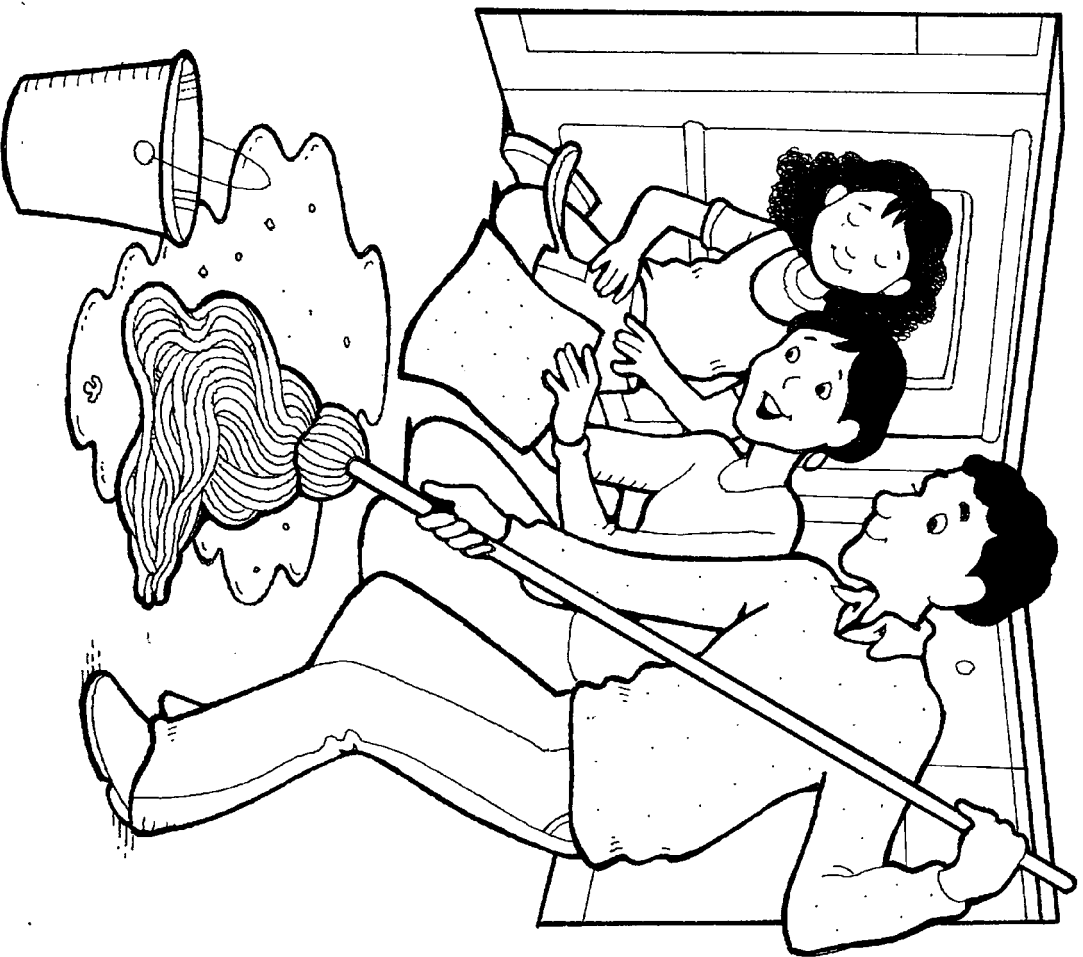

Dad mops a spot.

MHEonline.com



Copyright © 2015 McGraw-Hill Education

All rights reserved. The contents, or parts thereof, may be reproduced in print form for non-profit educational use with SRA Open Court Reading, provided such reproductions bear copyright notice, but may not be reproduced in any form for any other purpose without the prior written consent of McGraw-Hill Education, including, but not limited to, network storage or transmission, or broadcast for distance learning.

Send all inquiries to:  
McGraw-Hill Education  
8787 Orion Place  
Columbus, OH 43240

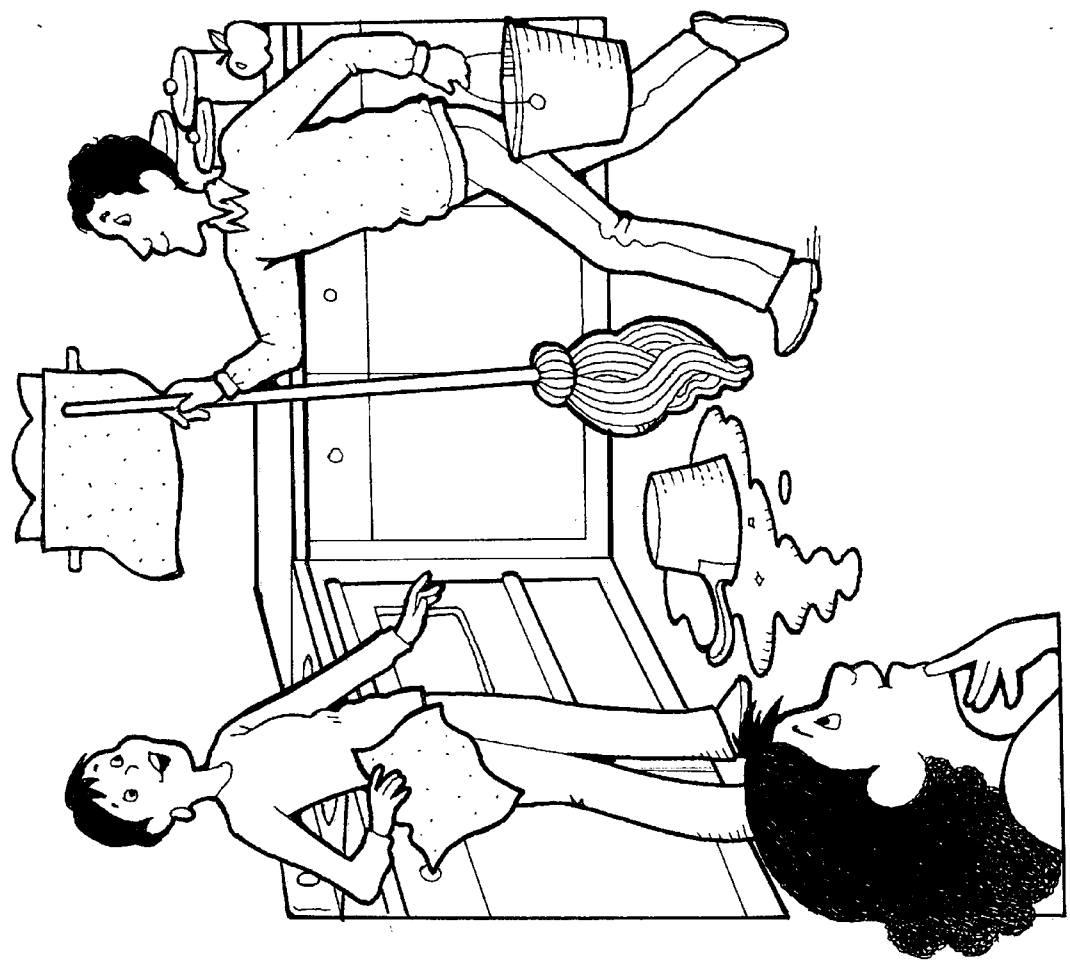

Dad has a mop.

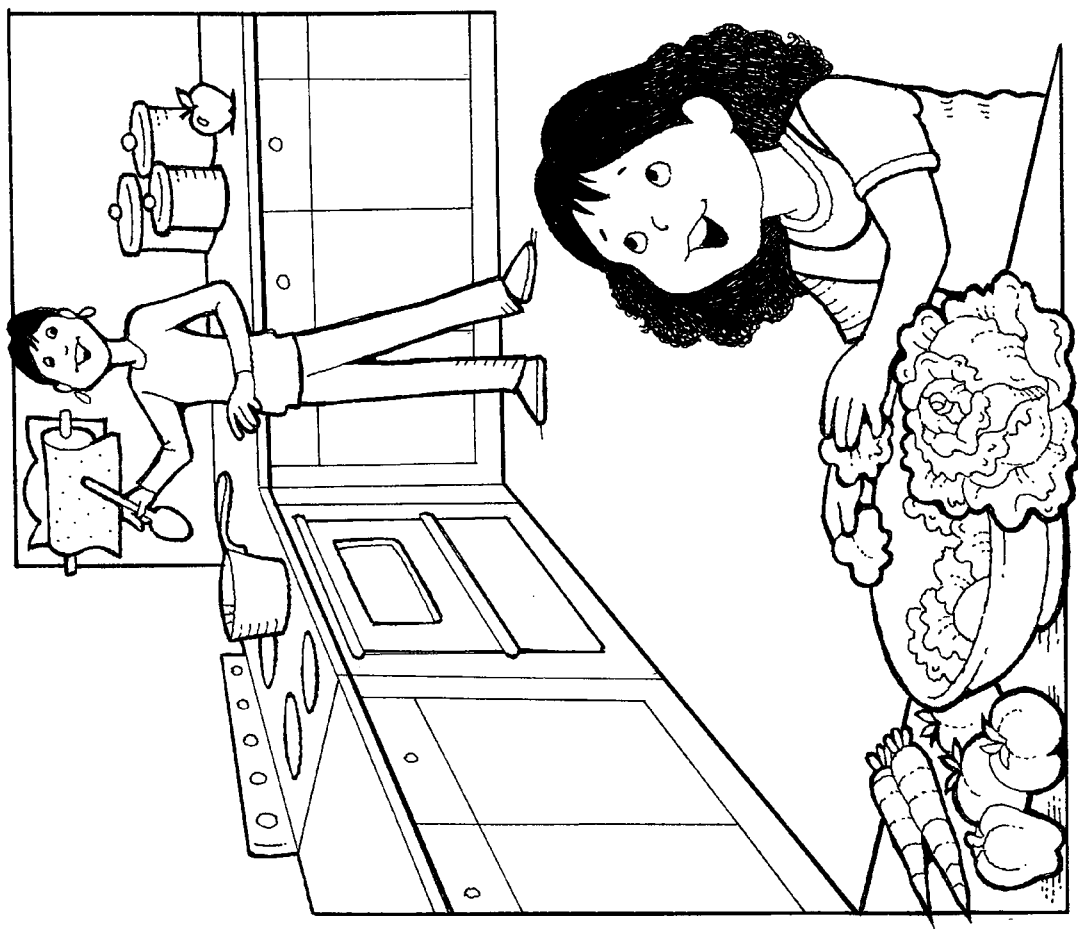

Mom has a pot.

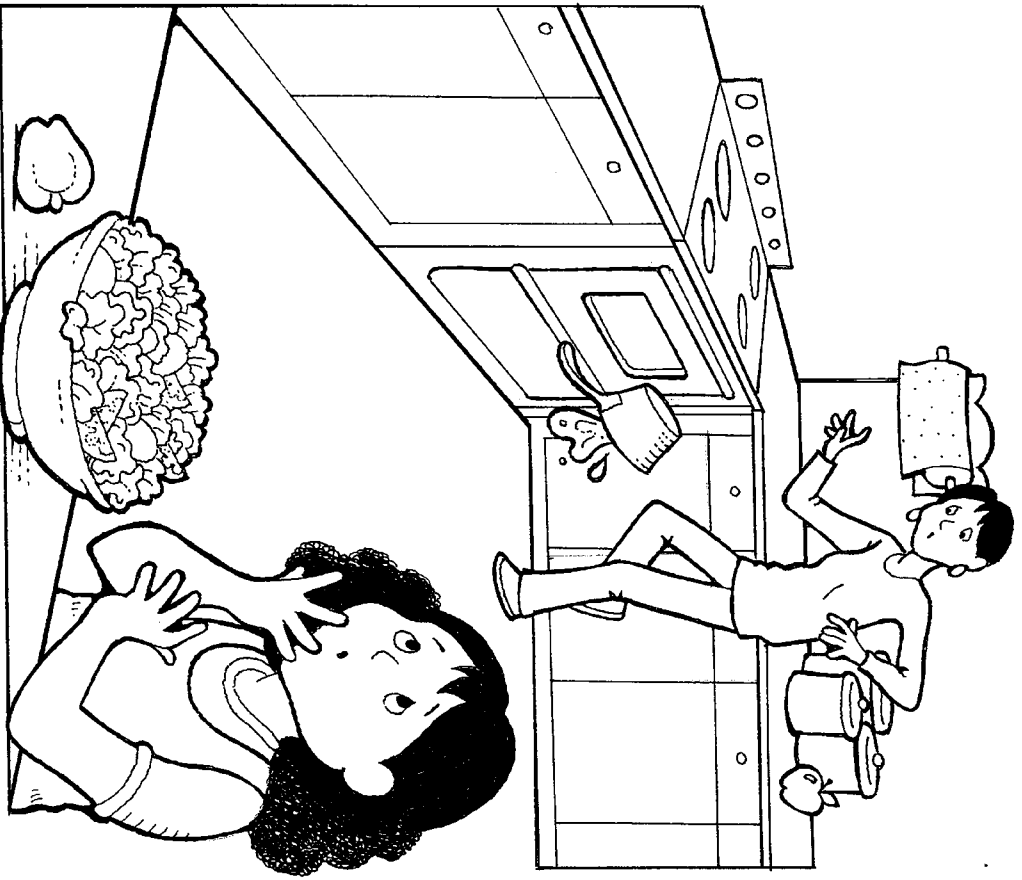

Mom has a hot pot.

The hot pot tips!

4

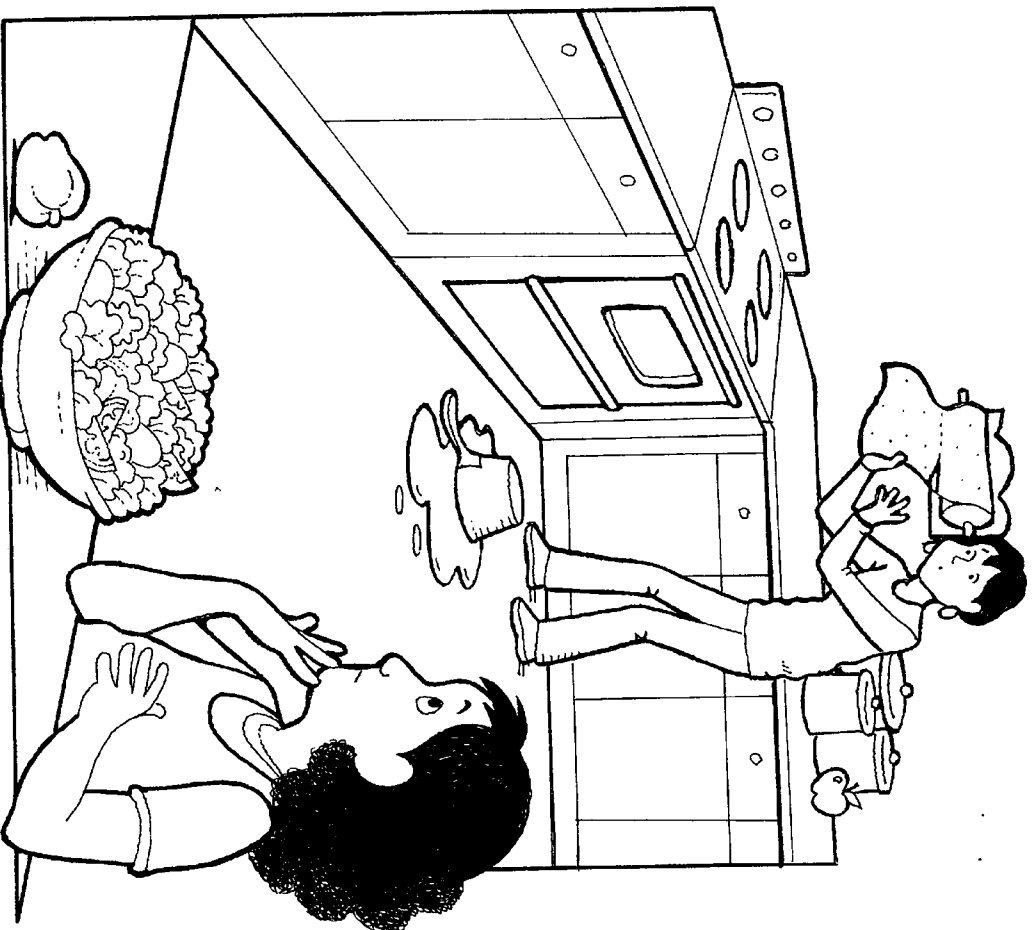

Mom has a spot.

5





Bob pants and pants.

# Bob at Bat

by Nicole Michael  
illustrated by Len Epstein

Core Decodable 17



Bothell, WA • Chicago, IL • Columbus, OH • New York, NY

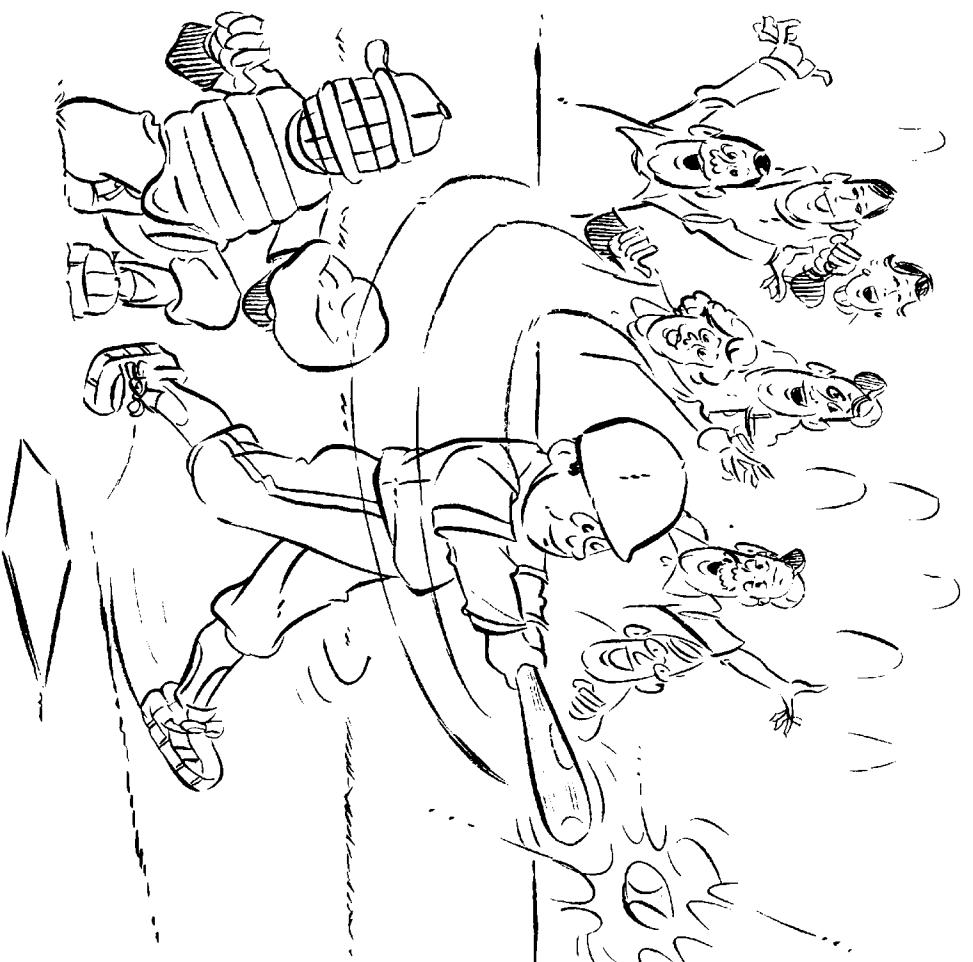

Bob bats. Bam!  
Bob has a hit!

MHEonline.com



Copyright © 2015 McGraw-Hill Education

All rights reserved. The contents, or parts thereof, may be reproduced in print form for non-profit educational use with *SRA Open Court Reading*, provided such reproductions bear copyright notice, but may not be reproduced in any form for any other purpose without the prior written consent of McGraw-Hill Education, including, but not limited to, network storage or transmission, or broadcast for distance learning.

Send all inquiries to:  
McGraw-Hill Education  
8787 Orion Place  
Columbus, OH 43240

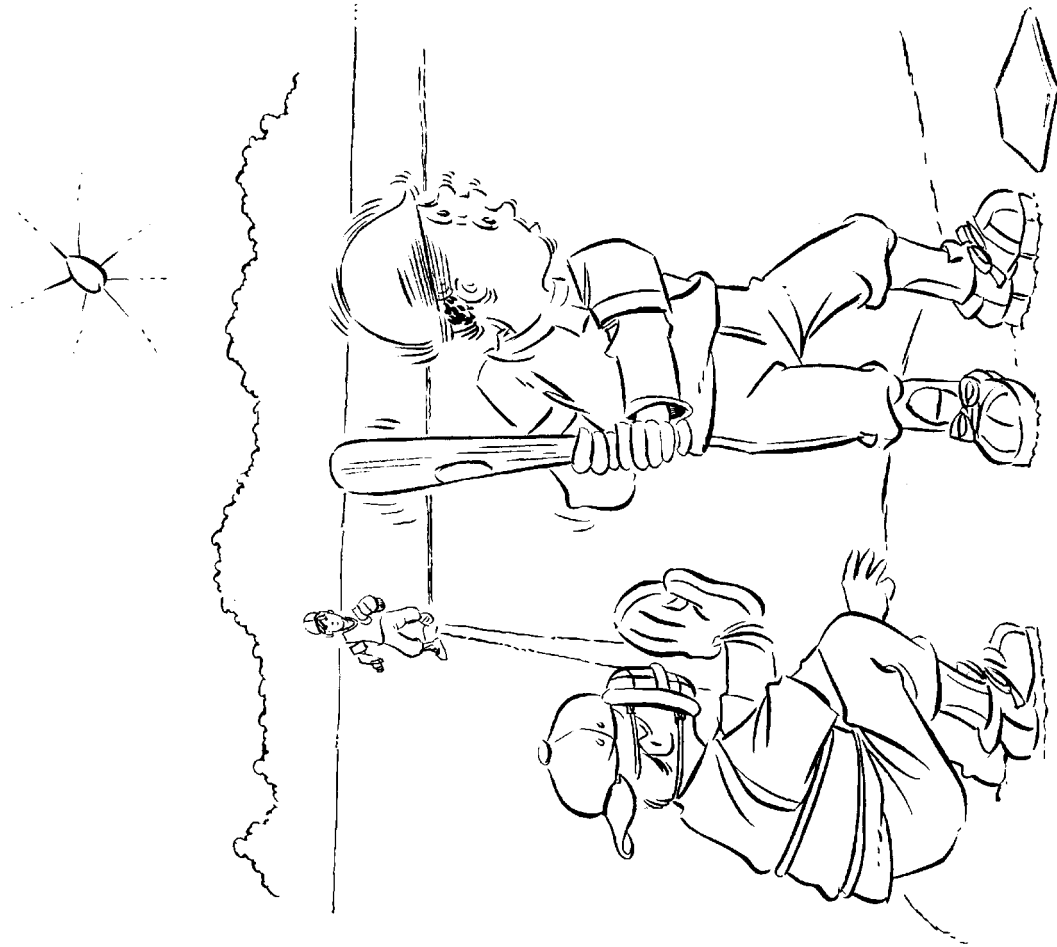

Bob can stand and nod.

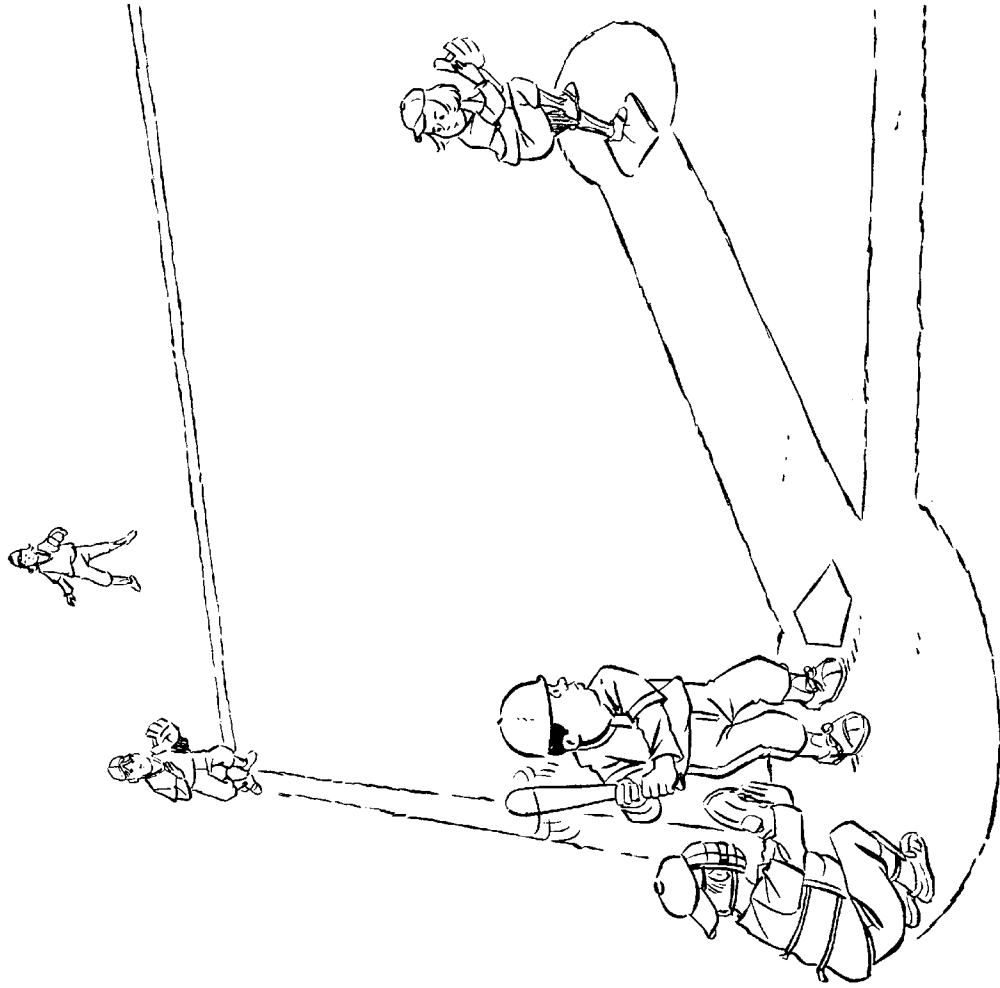

Bob is at bat.



Bob stomps a bat.

4



Bob taps a bat.

5

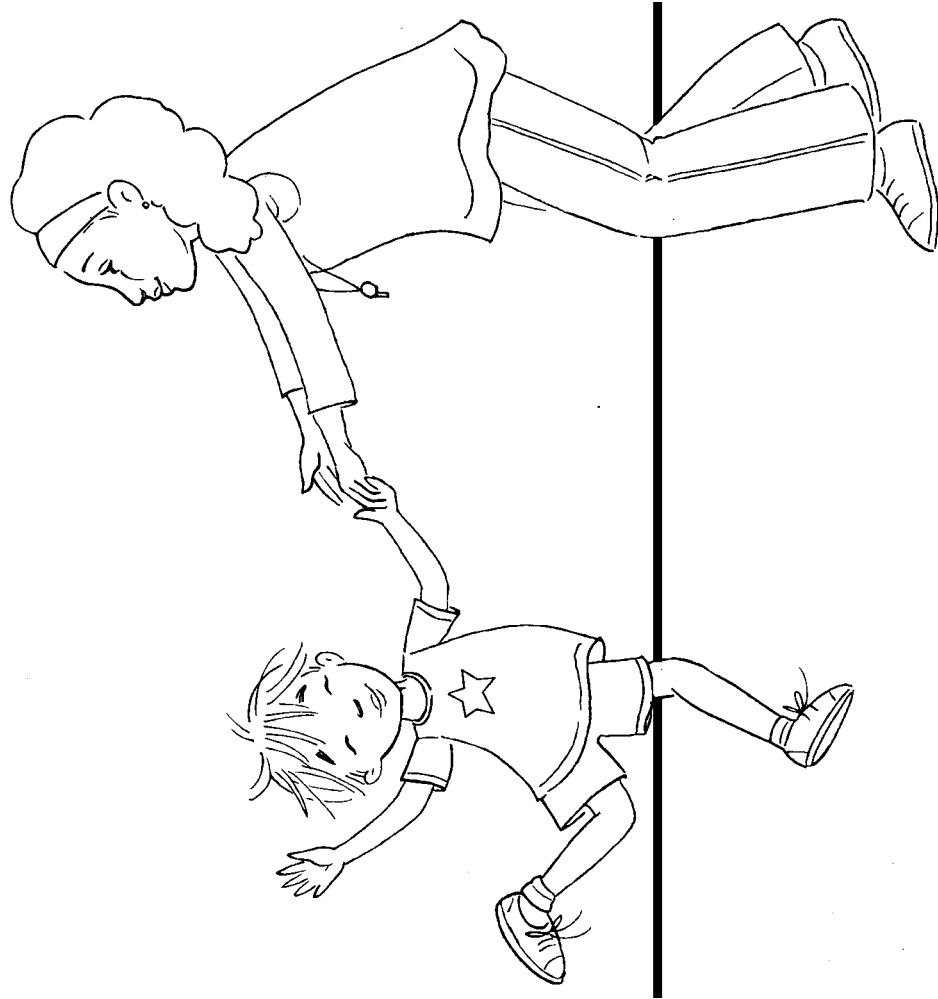

“I can hop, spin, and tap!”

# Bill

by Tamera Williams  
illustrated by Laura Logan

Core Decodable 18



Bothell, WA • Chicago, IL • Columbus, OH • New York, NY



MHEonline.com



Copyright © 2015 McGraw-Hill Education

All rights reserved. The contents, or parts thereof, may be reproduced in print form for non-profit educational use with *SRA Open Court Reading*, provided such reproductions bear copyright notice, but may not be reproduced in any form for any other purpose without the prior written consent of McGraw-Hill Education, including, but not limited to, network storage or transmission, or broadcast for distance learning.

Send all inquiries to:  
McGraw-Hill Education  
8787 Orion Place  
Columbus, OH 43240

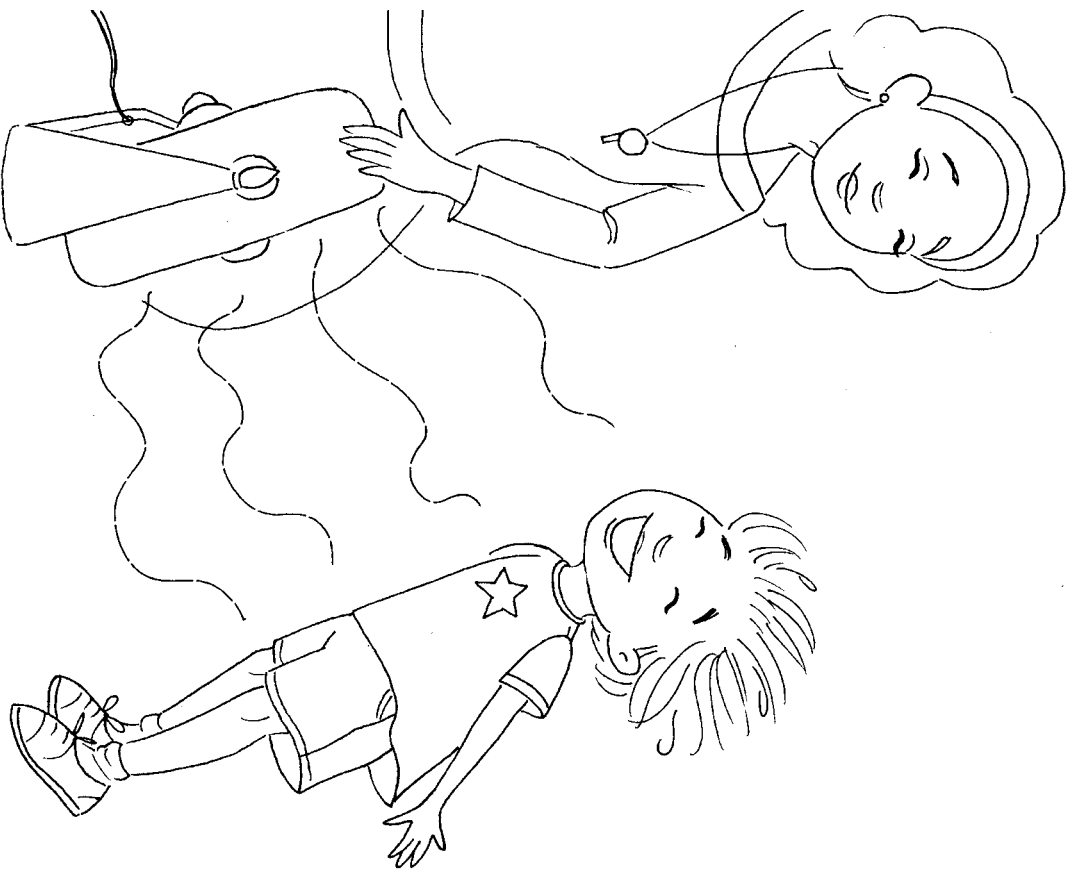

“I am not hot!” said Bill.

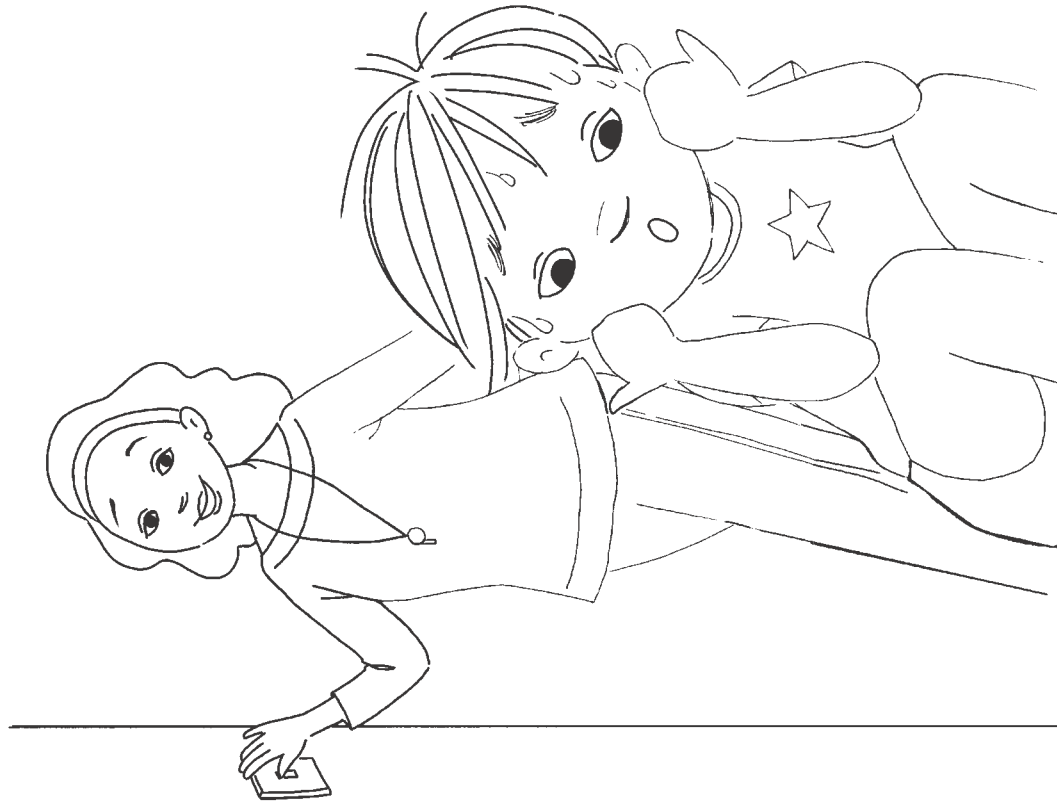

"I am hot, hot, hot!" said Bill.

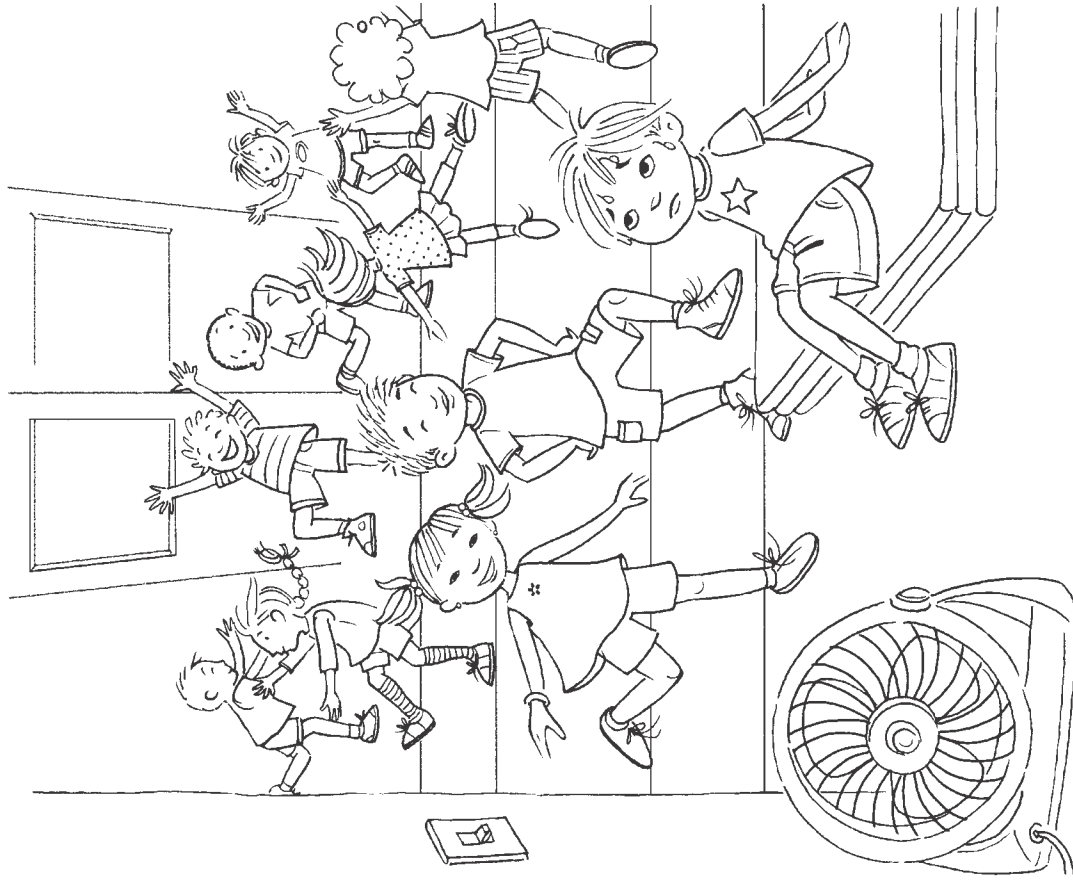

Pam and Bob hop past Bill.

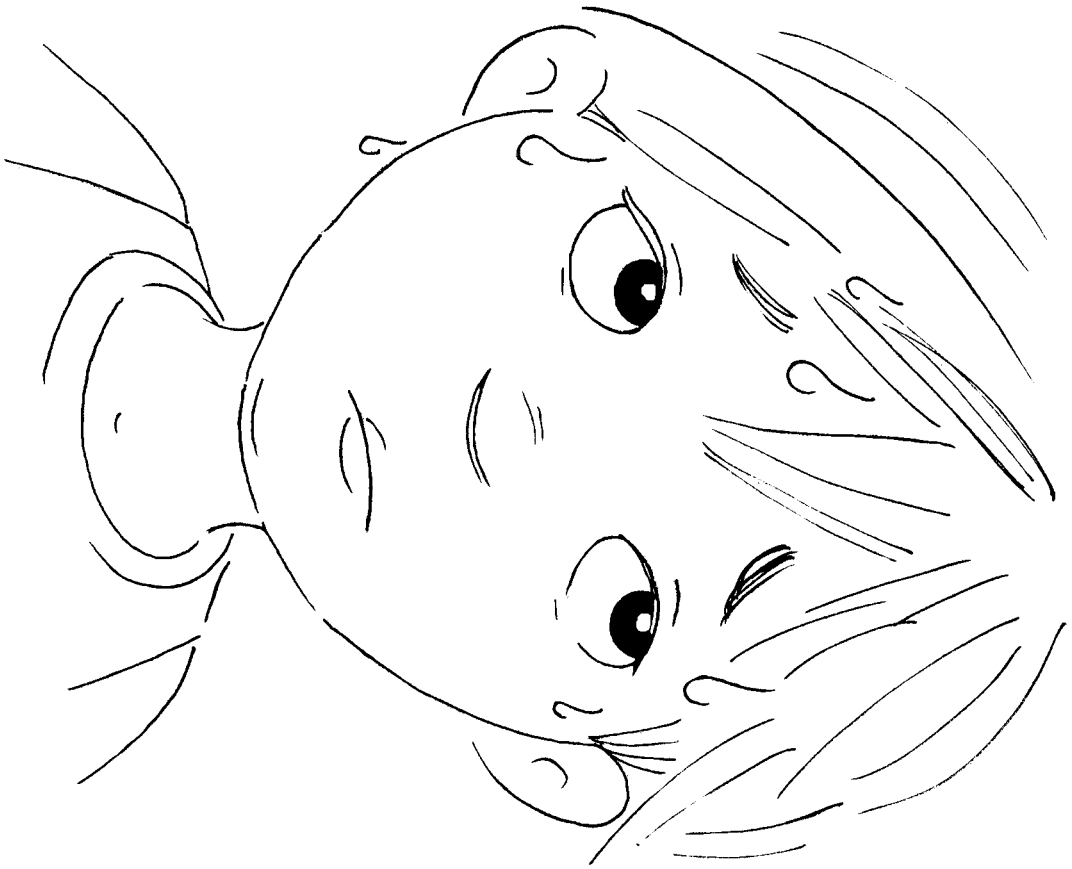

Bill did not hop.

4

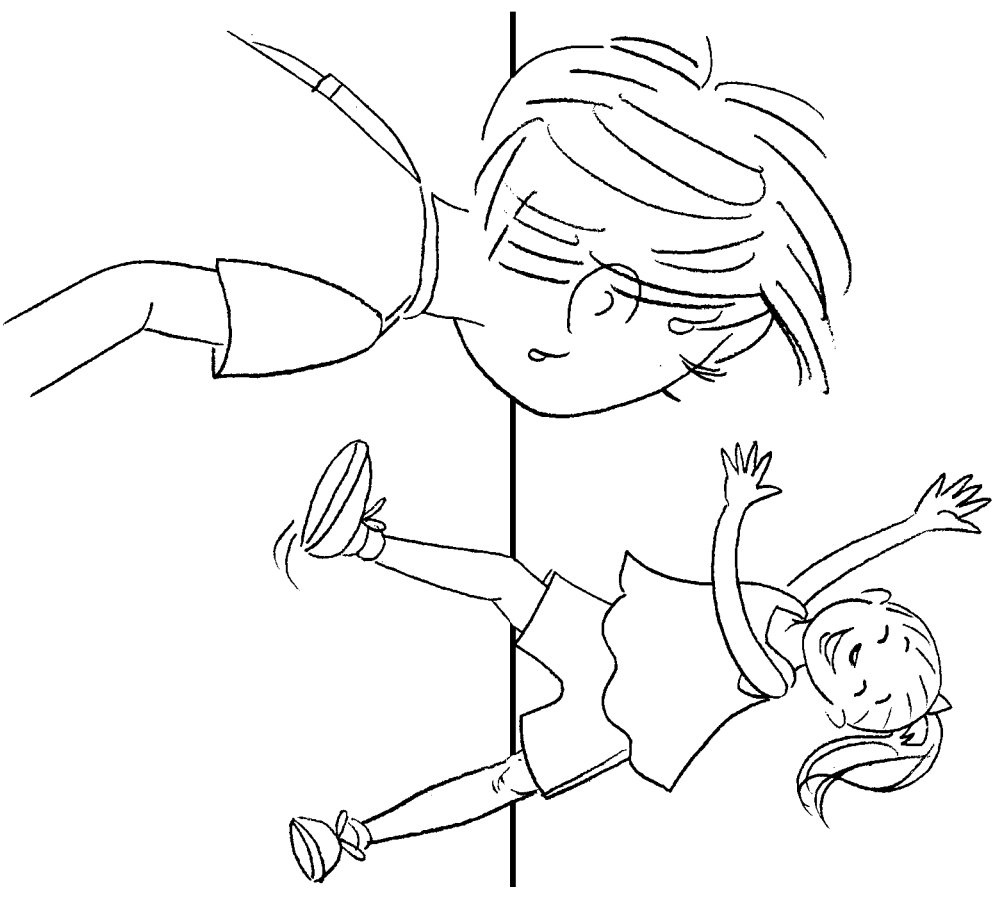

“Tap, Bill,” said Dot.

13

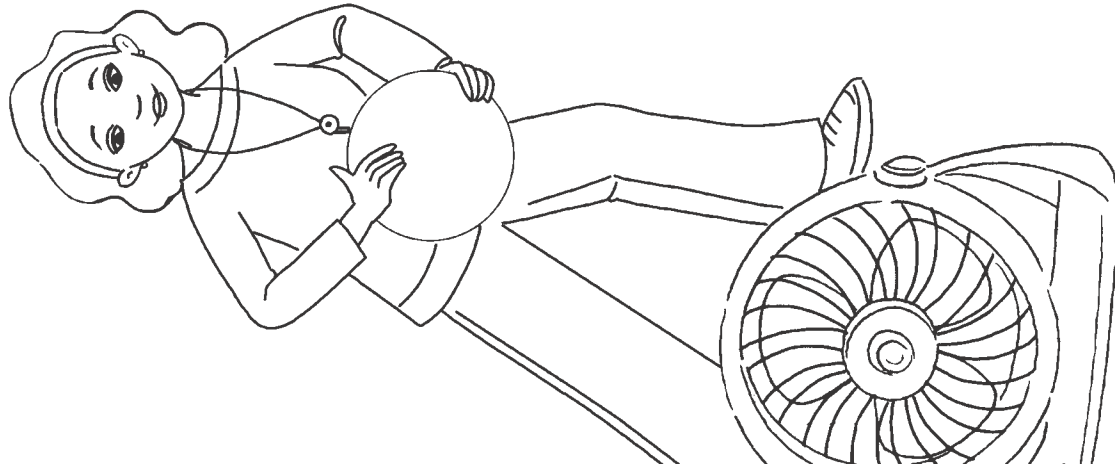

Bill did not tap.

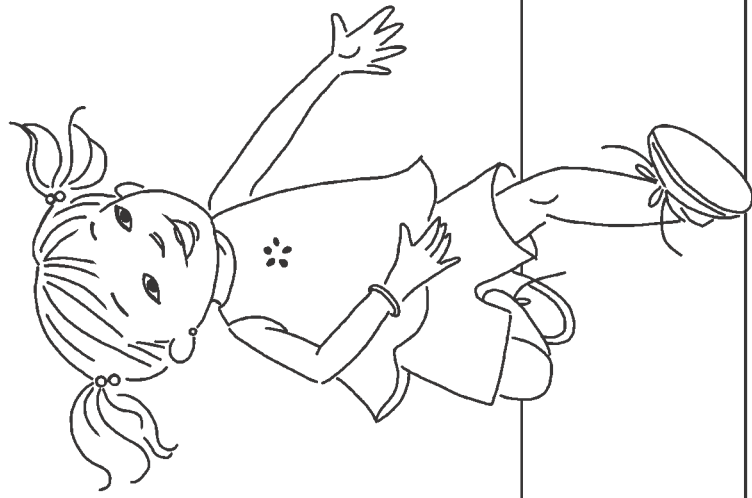

"Hop, Bill!" said Pam.

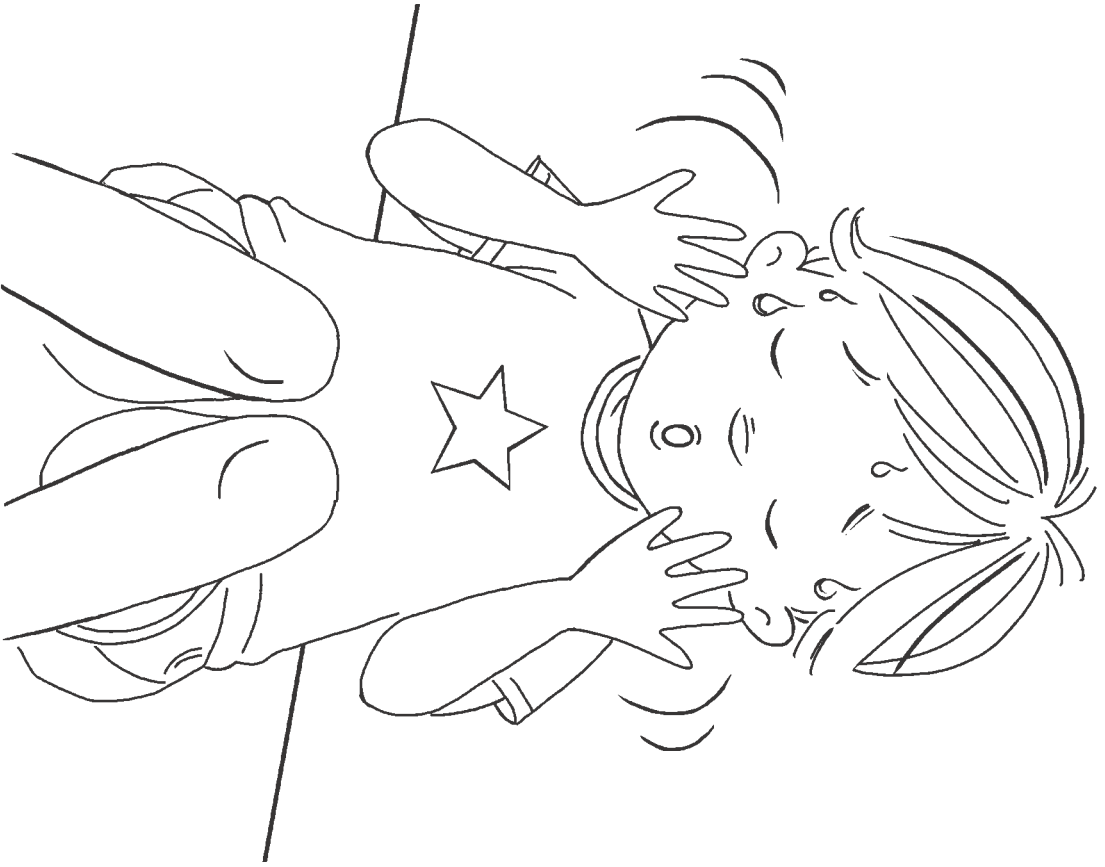

"I am hot," said Bill.

6



Dot and Al tap past Bill.

11



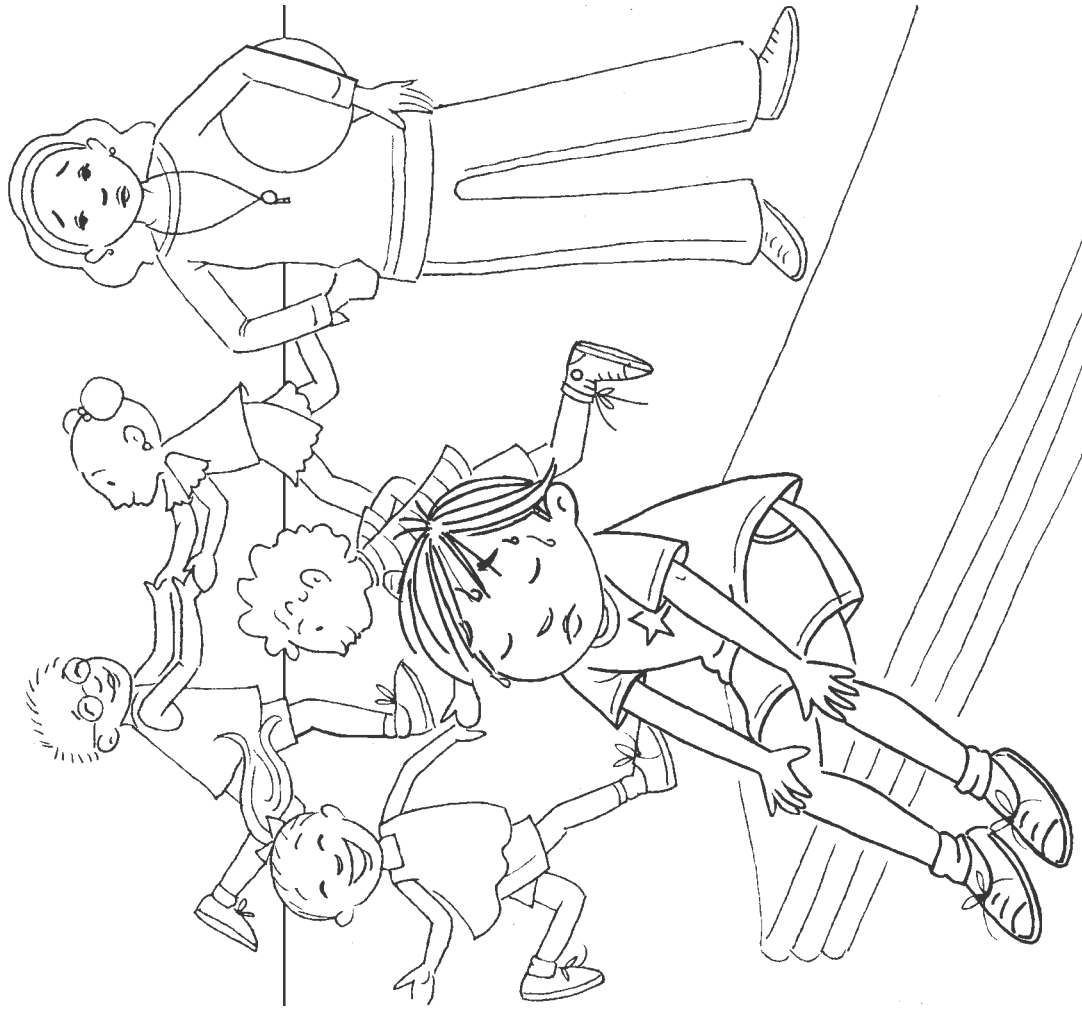

"I am still hot," said Bill.



Sam and Tom spin past Bill.

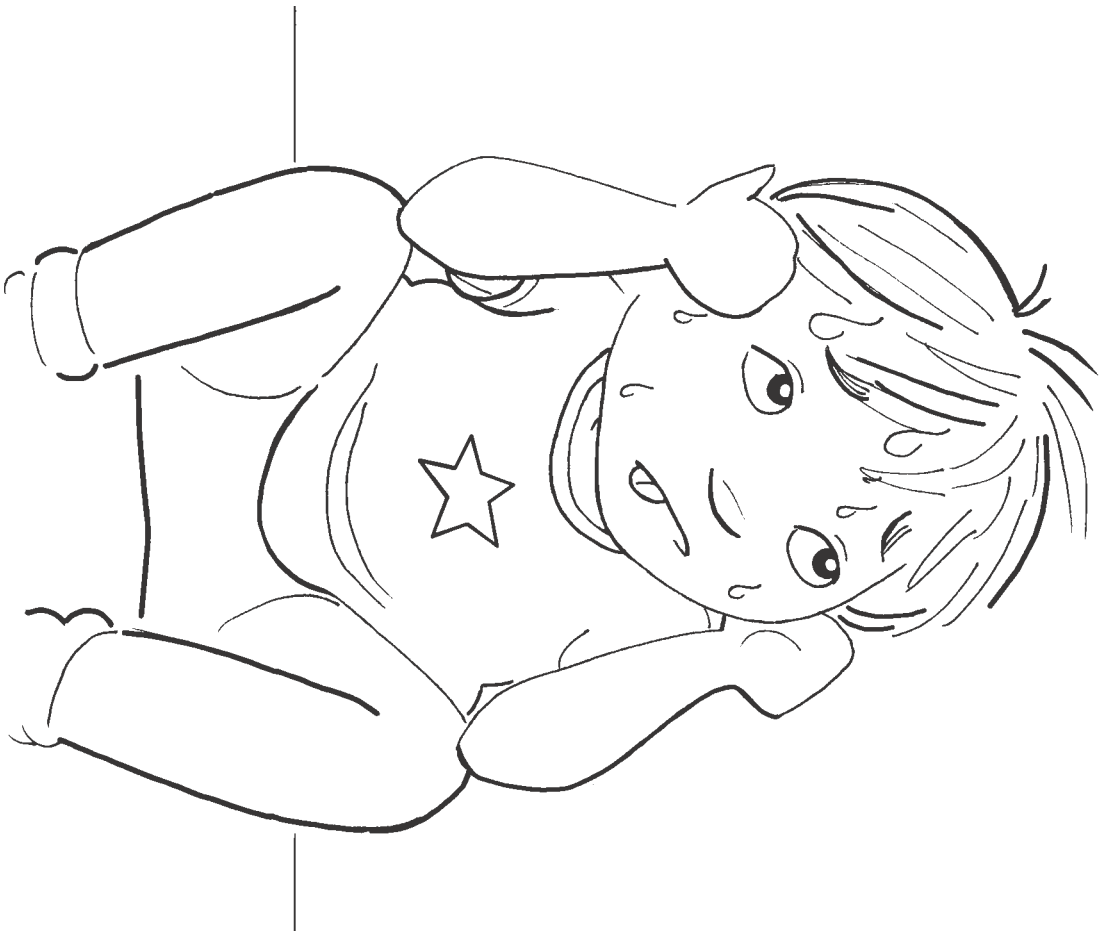

Bill did not spin.

8

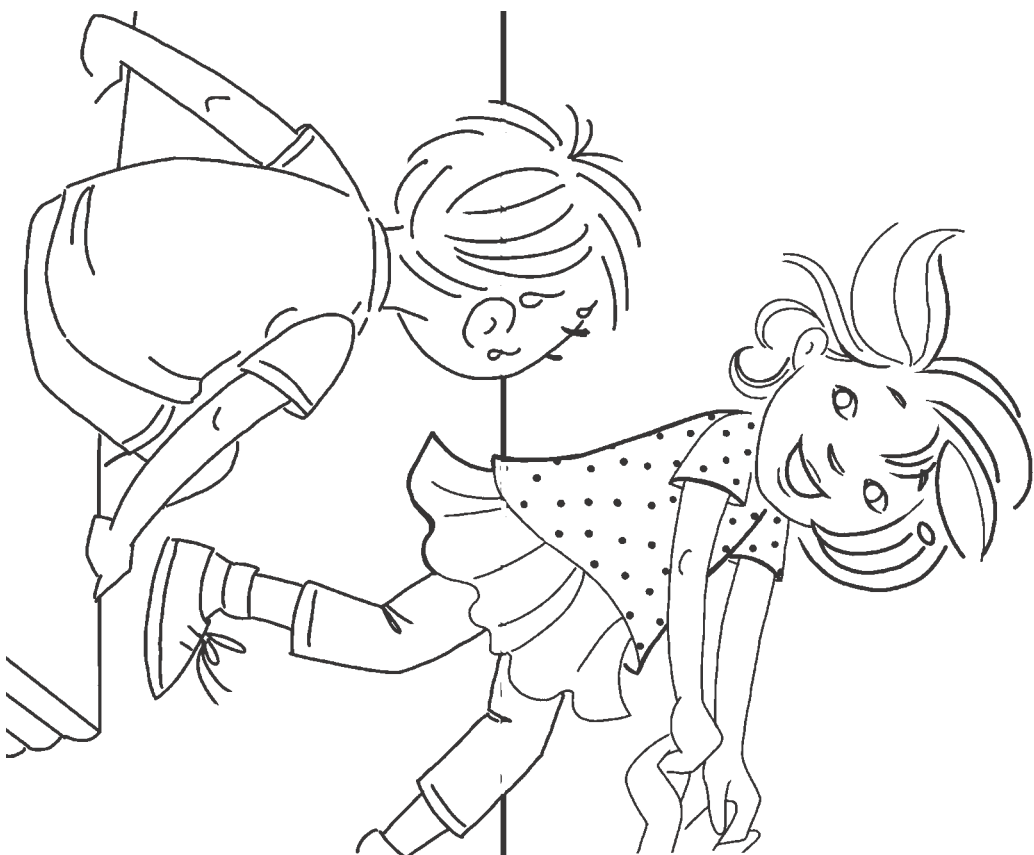

"Spin, Bill," said Sam.

9

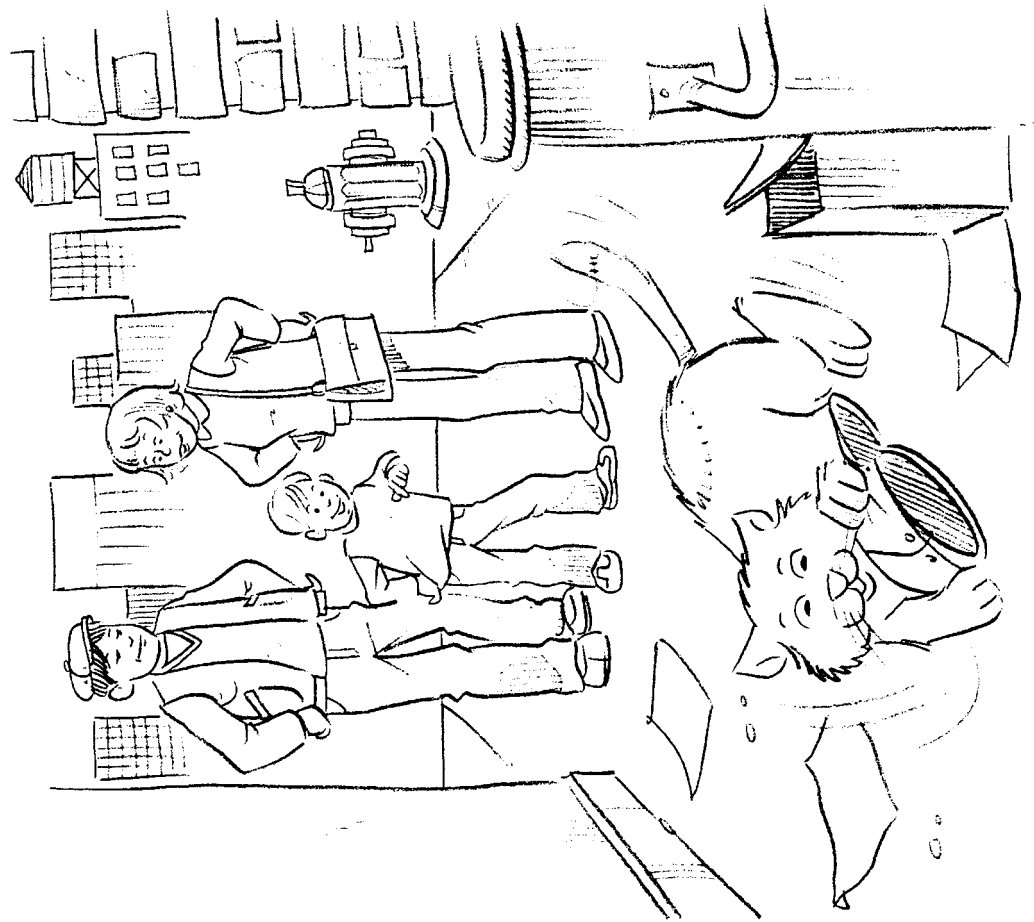

A cat can stop Nat's cap!

# Nat's Cap

by Andrew Lunn  
illustrated by Len Epstein

Core Decodable 19



Bothell, WA • Chicago, IL • Columbus, OH • New York, NY

MHEonline.com



Copyright © 2015 McGraw-Hill Education

All rights reserved. The contents, or parts thereof, may be reproduced in print form for non-profit educational use with *SRA Open Court Reading*, provided such reproductions bear copyright notice, but may not be reproduced in any form for any other purpose without the prior written consent of McGraw-Hill Education, including, but not limited to, network storage or transmission, or broadcast for distance learning.

Send all inquiries to:  
McGraw-Hill Education  
8787 Orion Place  
Columbus, OH 43240



Can Nat's cap stop?

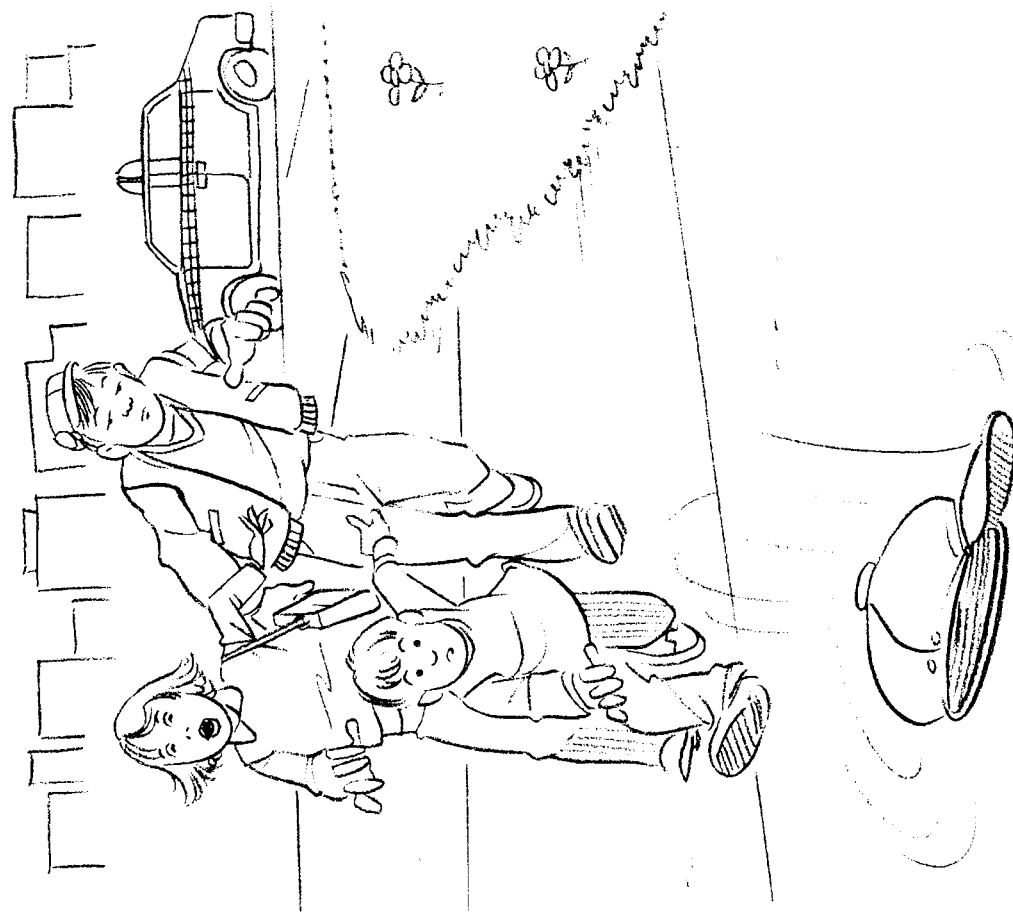

A cab can't stop Nat's cap.



Nat has a cap.



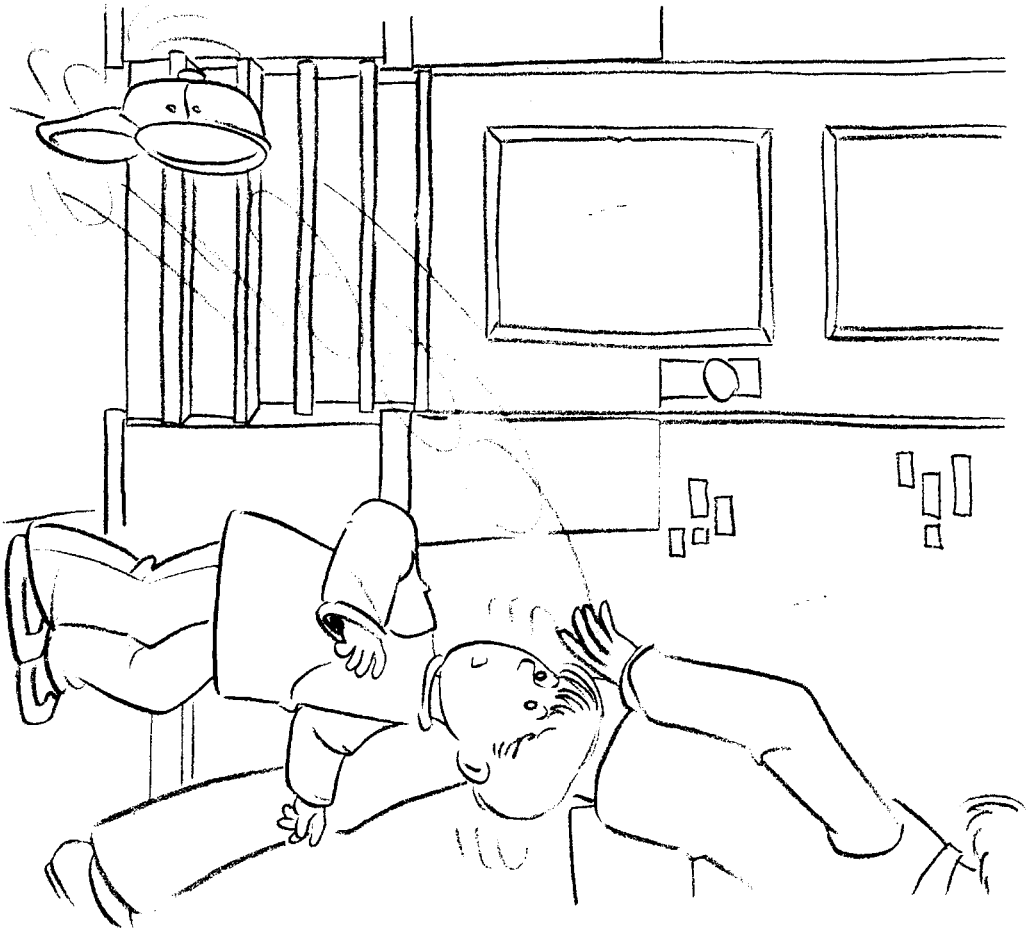

Can Mom stop Nat's capp?

4

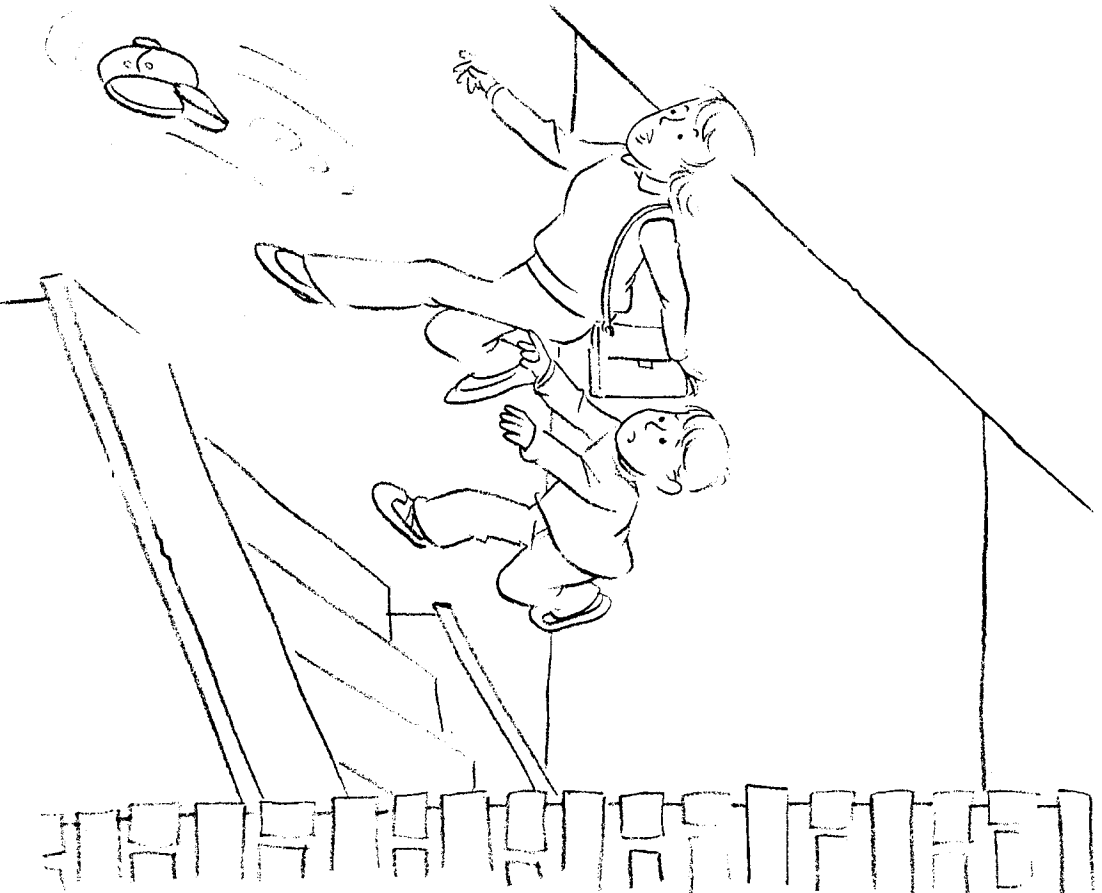

Mom can't stop Nat's capp.

5



“It is a small ball,” said Mom.

# At the Mall

by Kimberly Irving  
illustrated by Meryl Henderson

Core Decodable 20



Bothell, WA • Chicago, IL • Columbus, OH • New York, NY

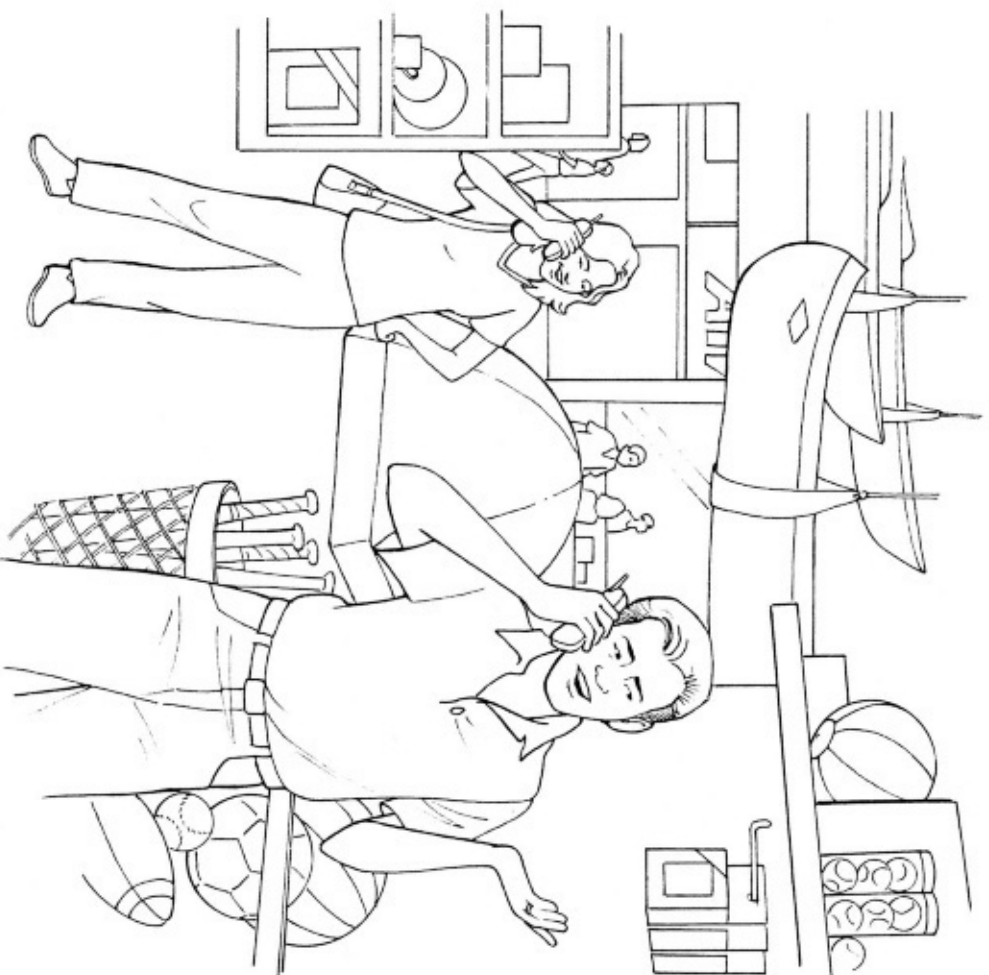

Dad did call.  
Mom is at the mall!

MHEonline.com



Copyright © 2015 McGraw-Hill Education

All rights reserved. The contents, or parts thereof, may be reproduced in print form for non-profit educational use with *SRA Open Court Reading*, provided such reproductions bear copyright notice, but may not be reproduced in any form for any other purpose without the prior written consent of McGraw-Hill Education, including, but not limited to, network storage or transmission, or broadcast for distance learning.

Send all inquiries to:  
McGraw-Hill Education  
8787 Orion Place  
Columbus, OH 43240

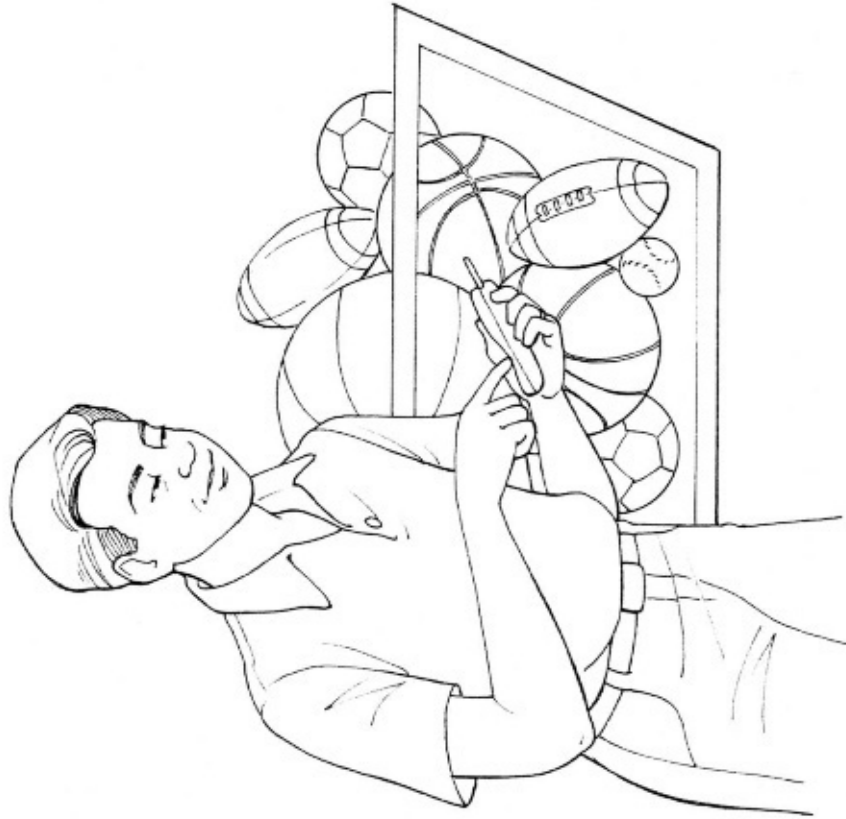

Dad is calm.

"I can call Mom," Dad said.



Dad sits in a mall.

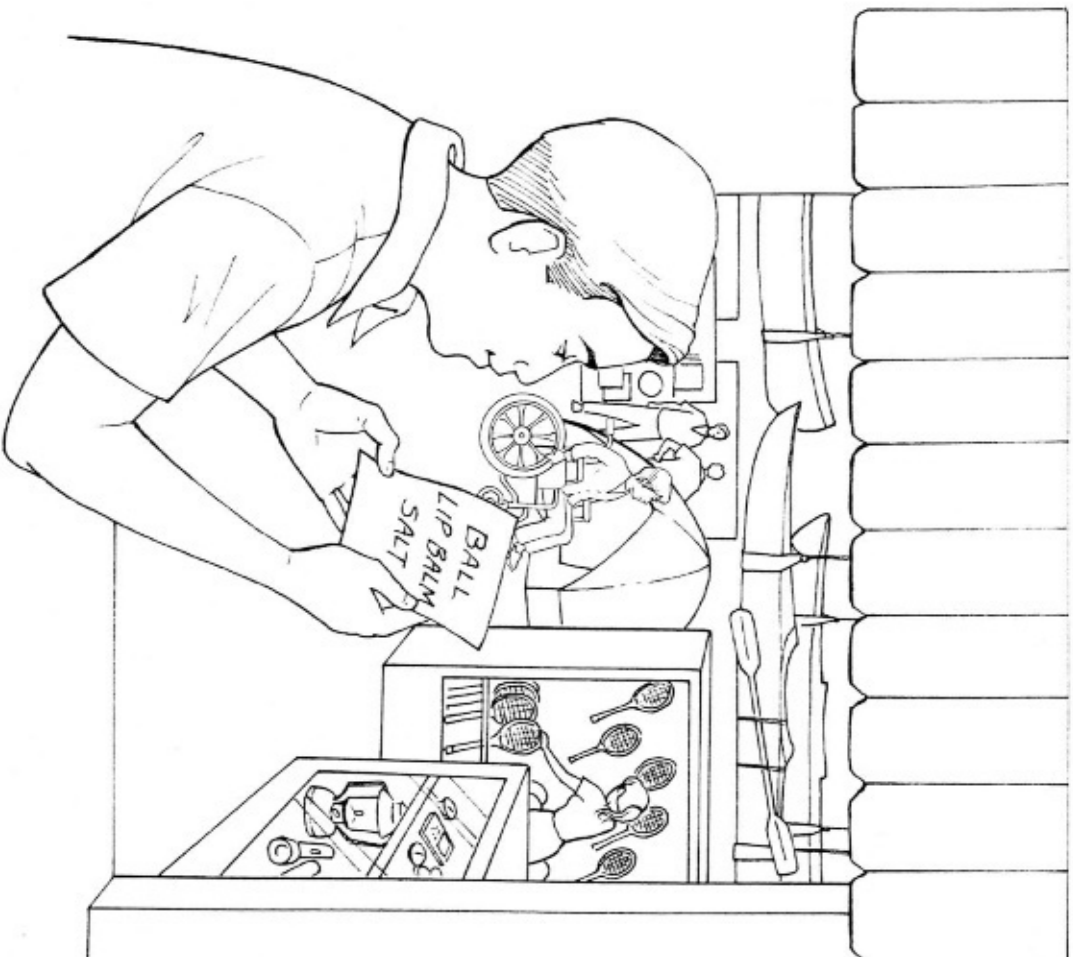

Dad has a list.

4

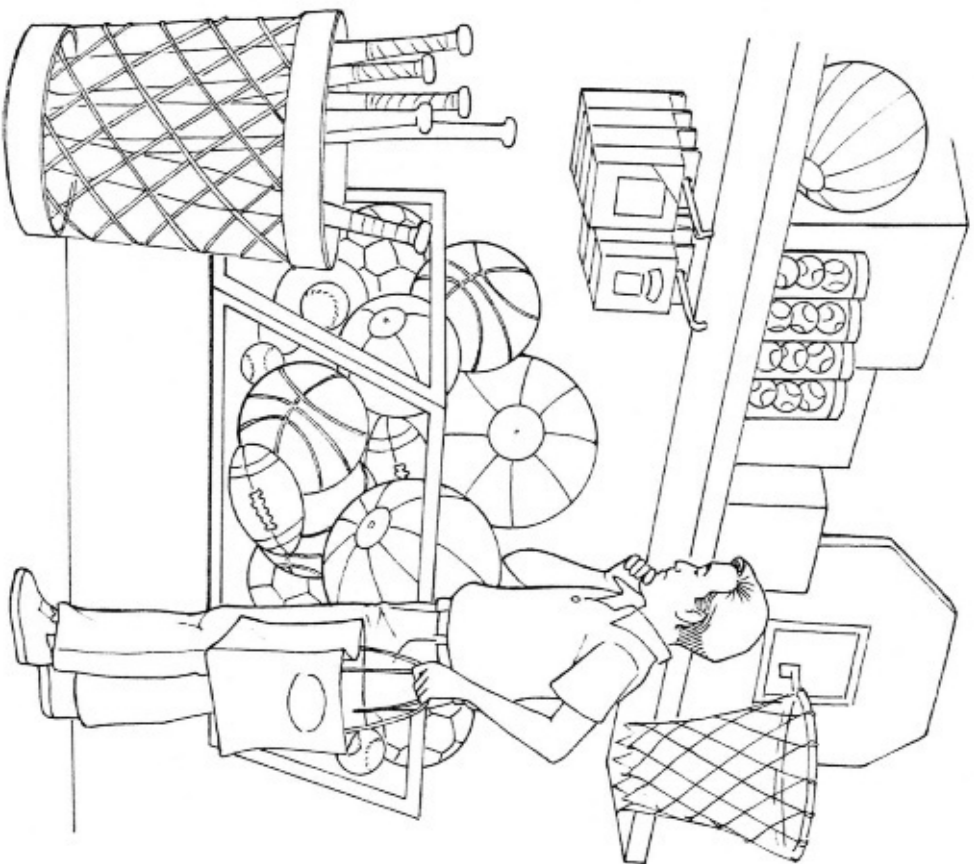

Is it a small ball?

5



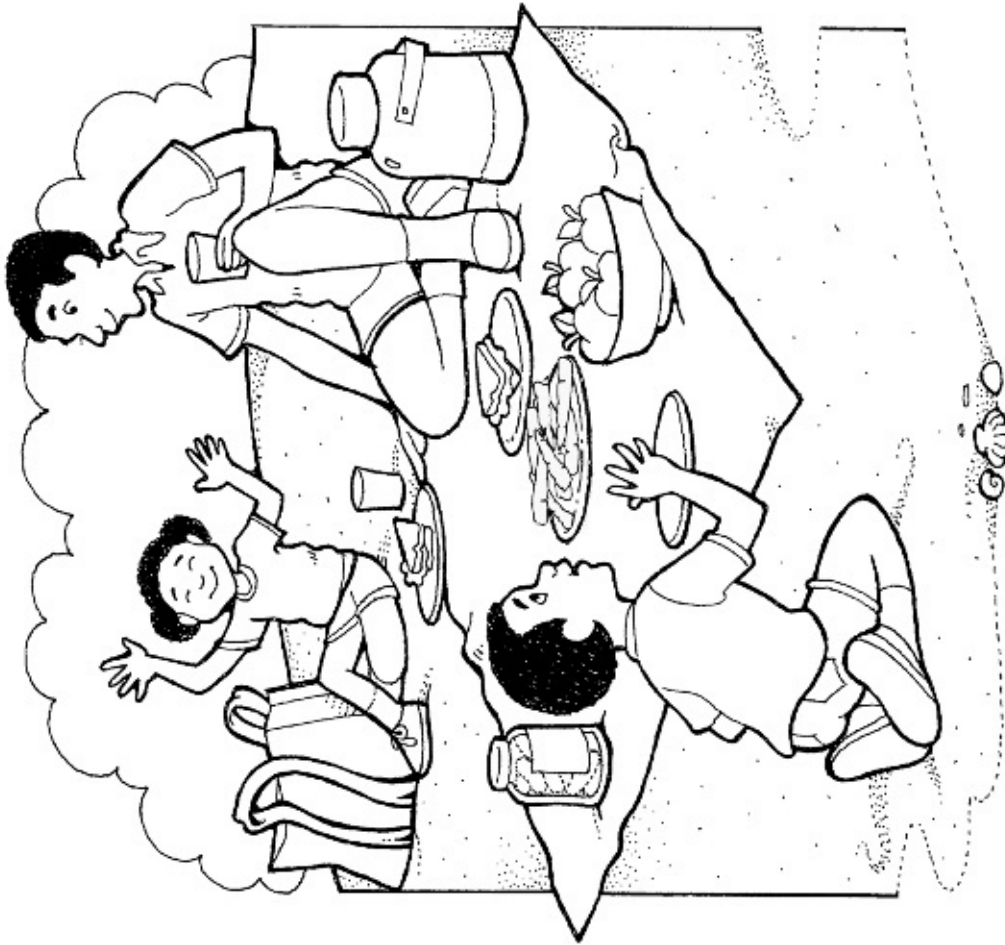

Dad, Nick, and Kim picnic.

# Picnic

by Pam Matthews  
illustrated by Olivia Cole

Core Decodable 21



Bothell, WA • Chicago, IL • Columbus, OH • New York, NY



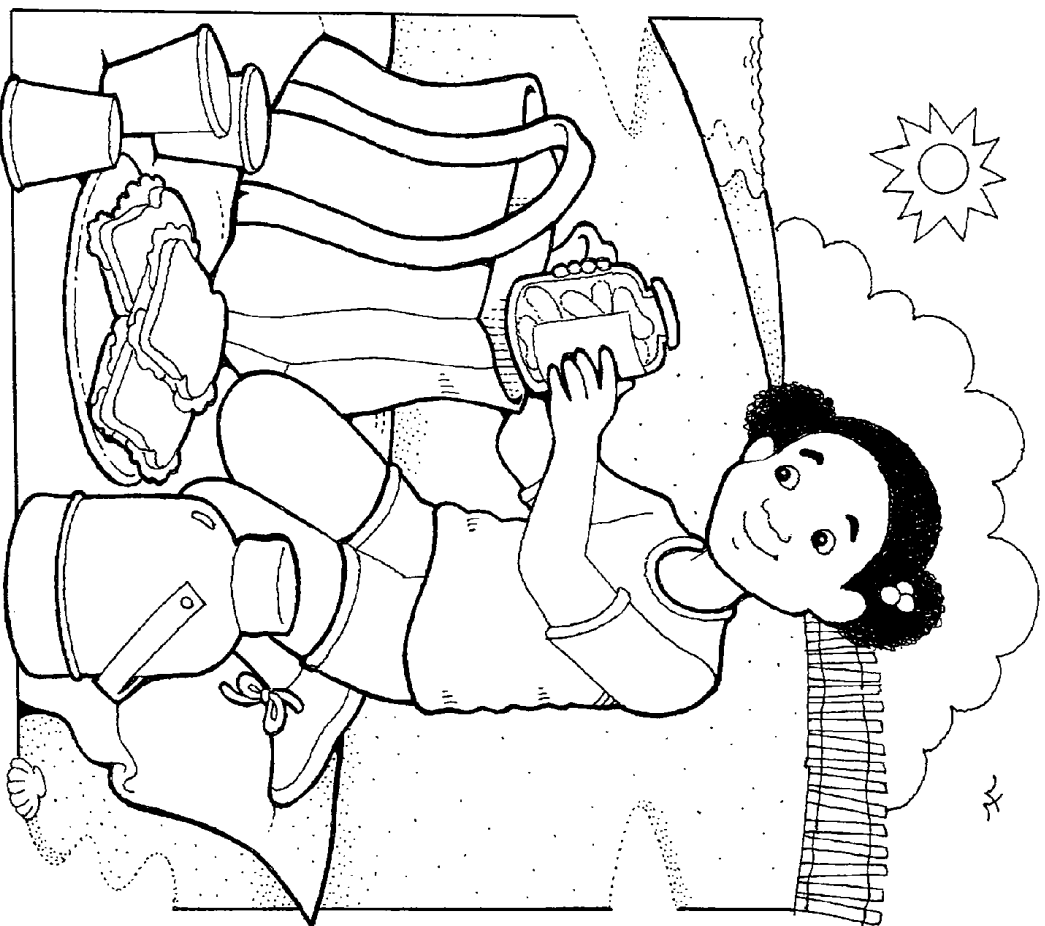

Kim has the picnic sack.  
Kim has milk and snacks.

MHEonline.com



Copyright © 2015 McGraw-Hill Education

All rights reserved. The contents, or parts thereof, may be reproduced in print form for non-profit educational use with *SRA Open Court Reading*, provided such reproductions bear copyright notice, but may not be reproduced in any form for any other purpose without the prior written consent of McGraw-Hill Education, including, but not limited to, network storage or transmission, or broadcast for distance learning.

Send all inquiries to:  
McGraw-Hill Education  
8787 Orion Place  
Columbus, OH 43240

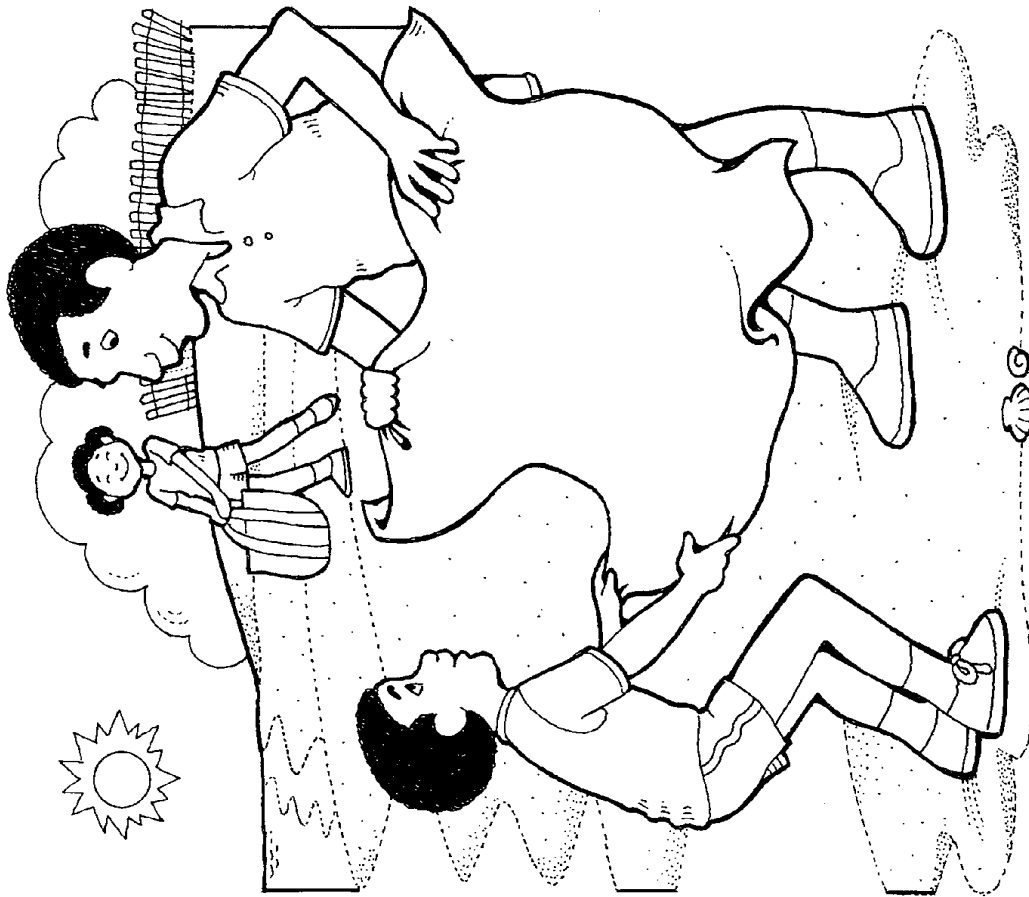

Dad and Nick stand.  
Kim skips in the sand.

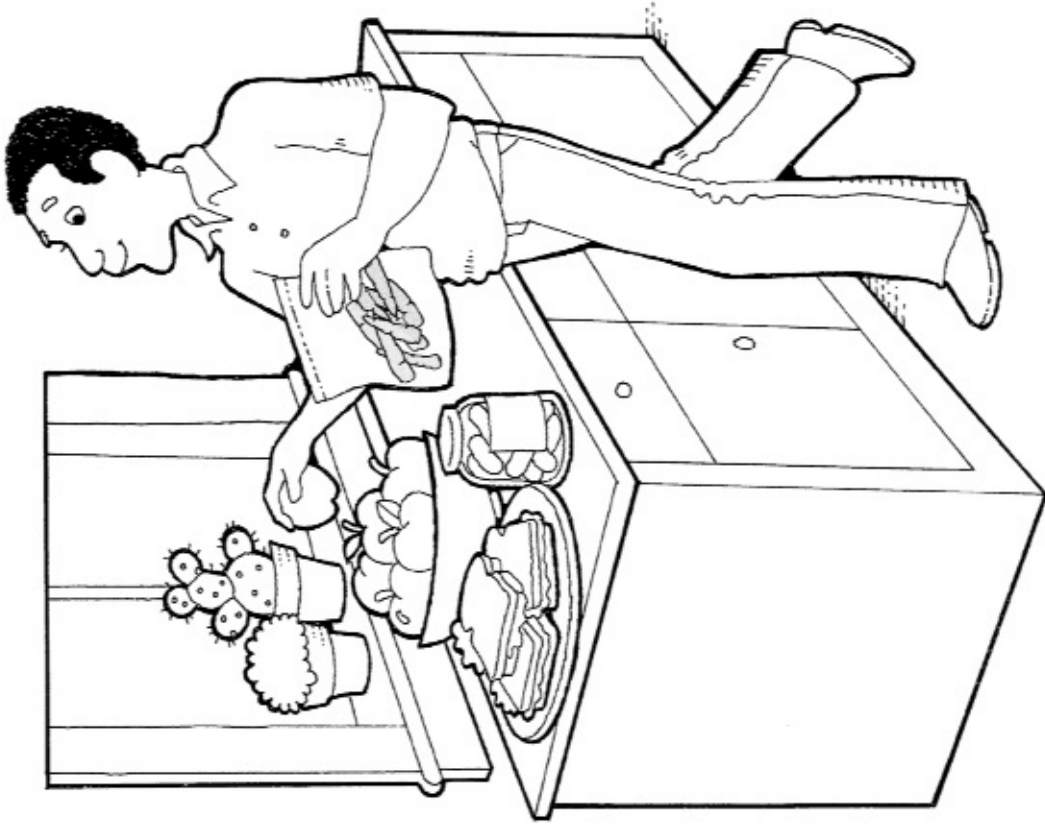

Dad can pick snacks.

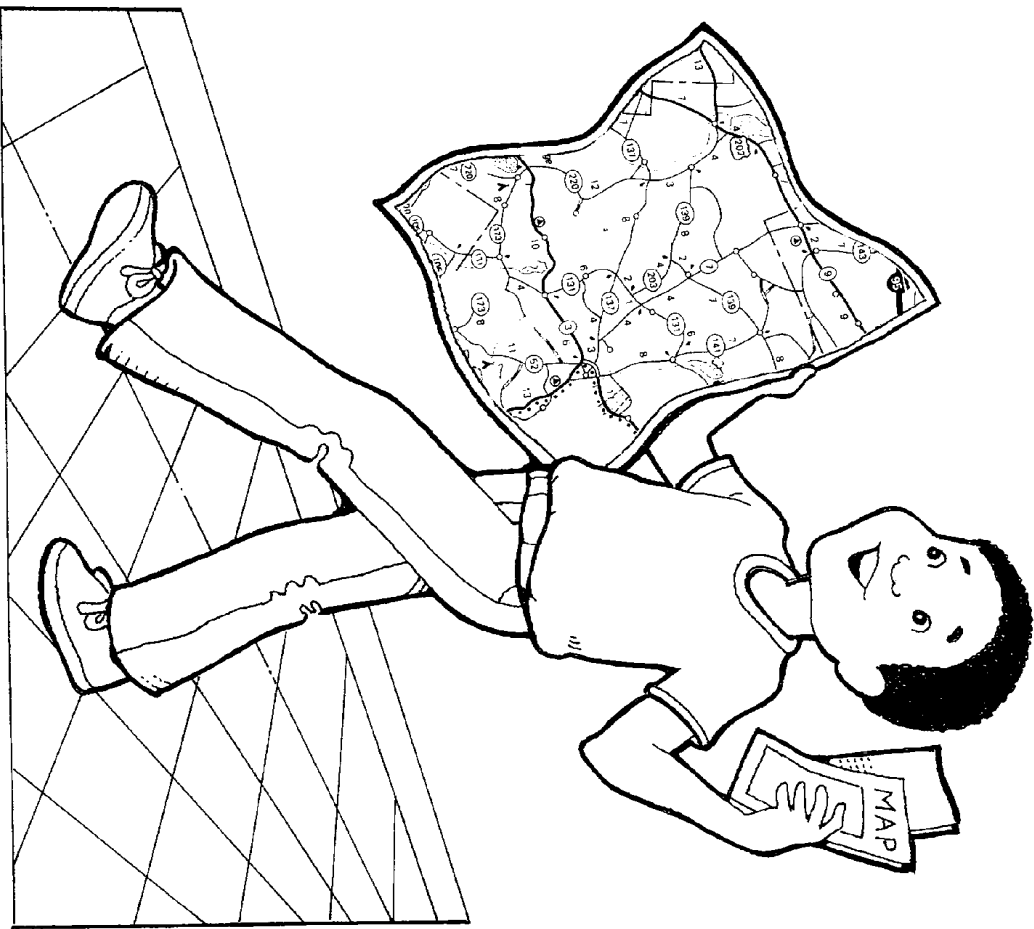

Nick can pack maps.

4

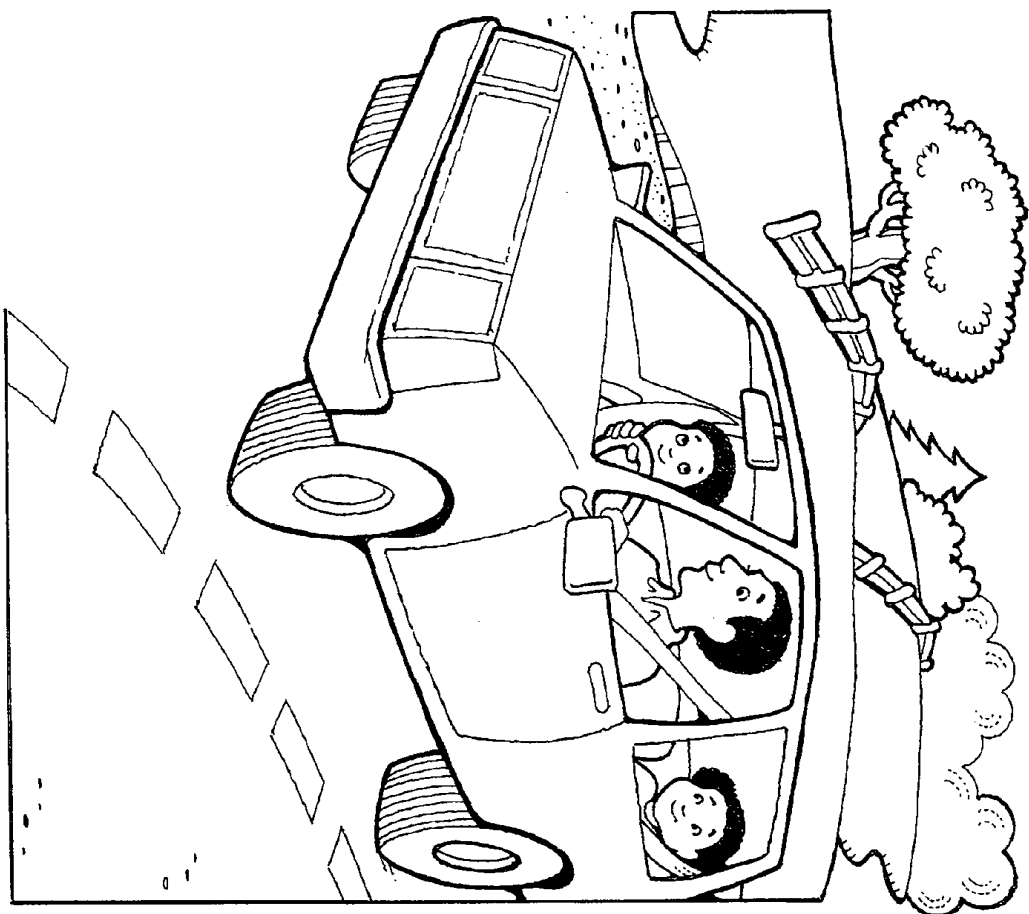

Kim sits in the back.

5



Rob sprints and licks Rick.

# Rick and Rob

by Rich White  
illustrated by Kersti Frigell

Core Decodable 22



Bothell, WA • Chicago, IL • Columbus, OH • New York, NY

MHEonline.com



Copyright © 2015 McGraw-Hill Education

All rights reserved. The contents, or parts thereof, may be reproduced in print form for non-profit educational use with *SRA Open Court Reading*, provided such reproductions bear copyright notice, but may not be reproduced in any form for any other purpose without the prior written consent of McGraw-Hill Education, including, but not limited to, network storage or transmission, or broadcast for distance learning.

Send all inquiries to:  
McGraw-Hill Education  
8787 Orion Place  
Columbus, OH 43240

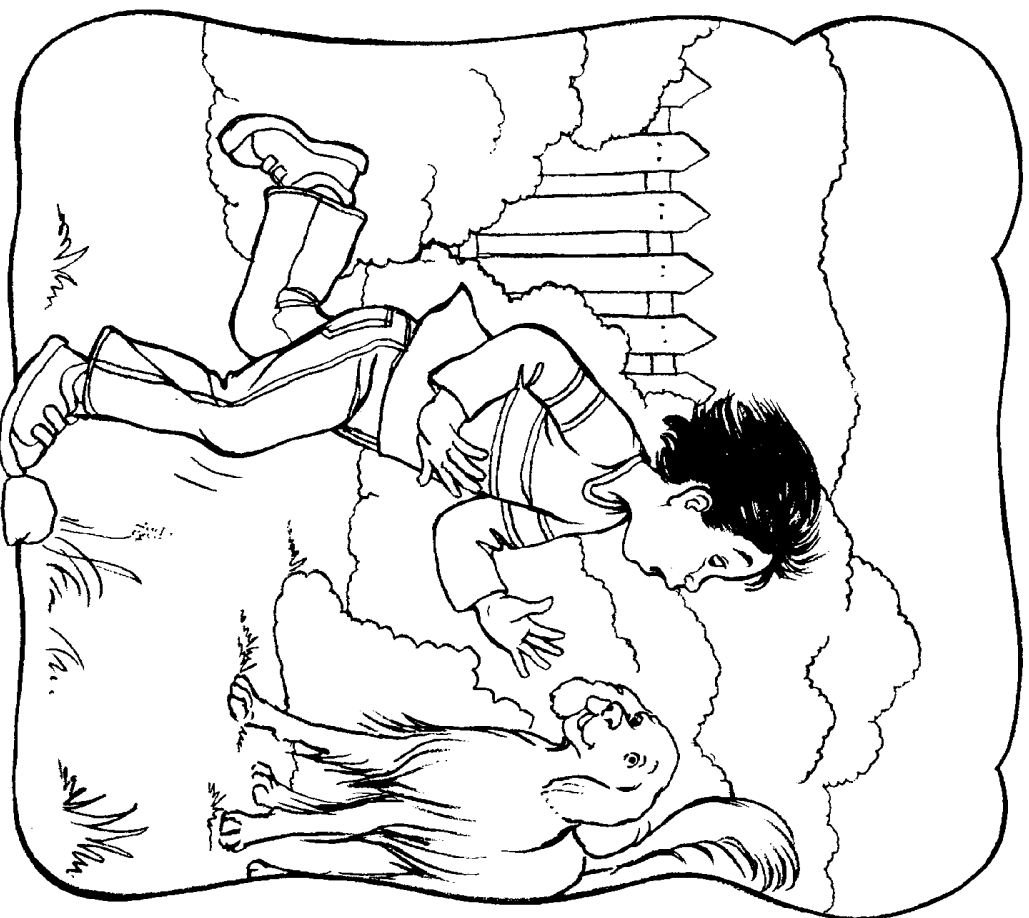

Rick sprints and trips on a rock.

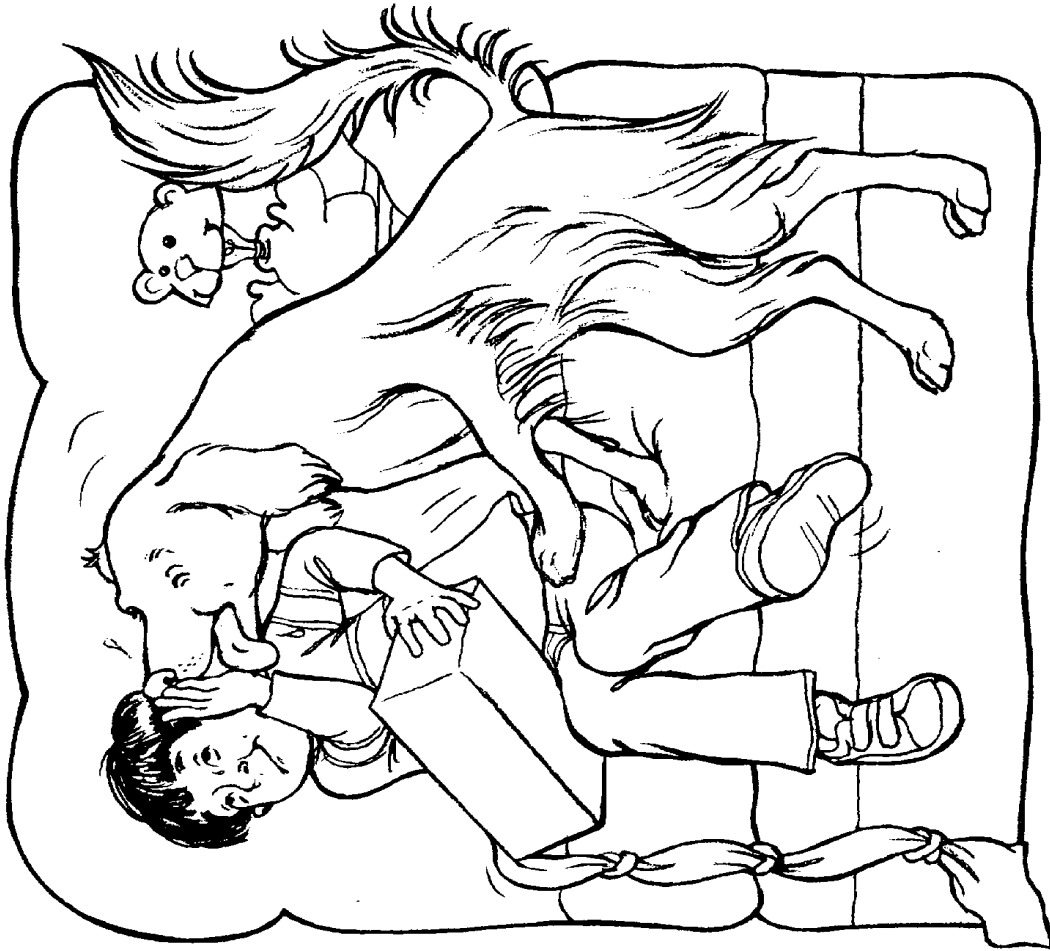

Rob licks Rick. Rick can't pick a trick.

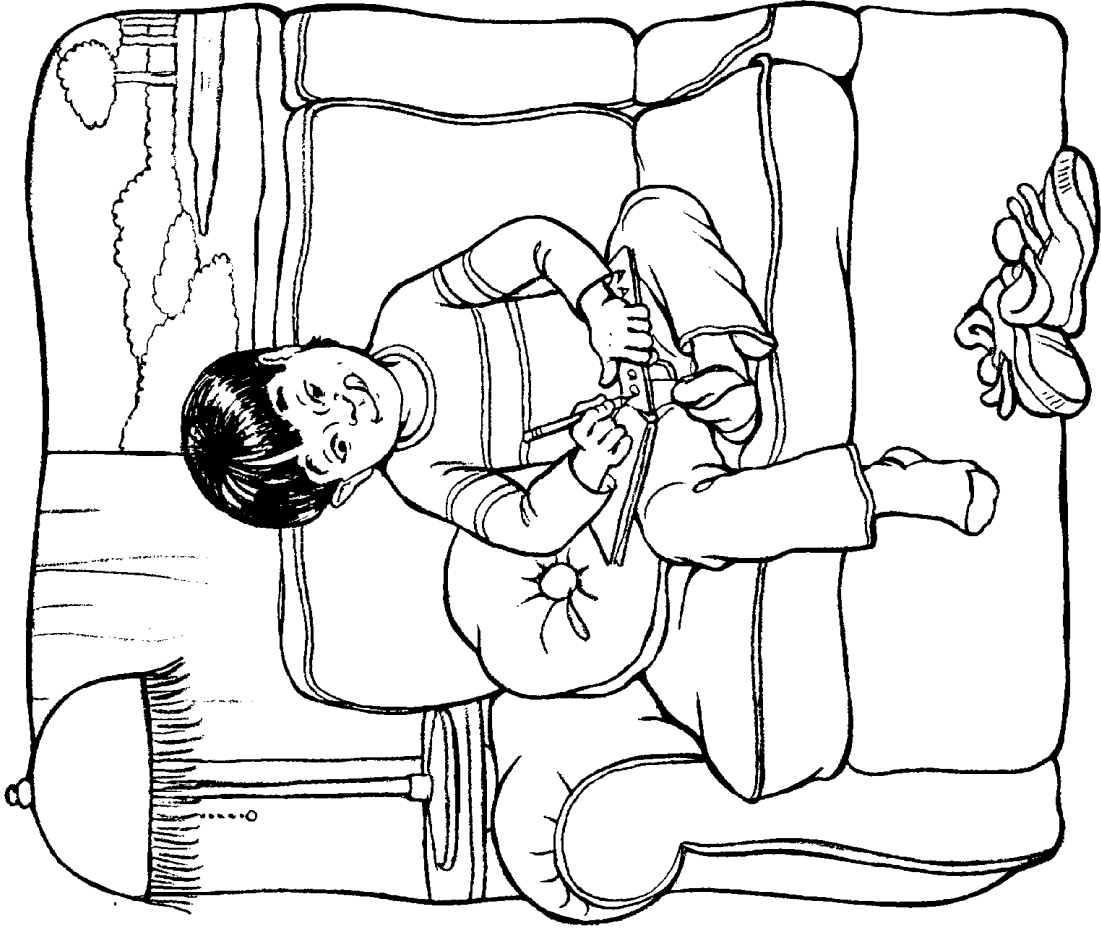

Rick sits and prints.



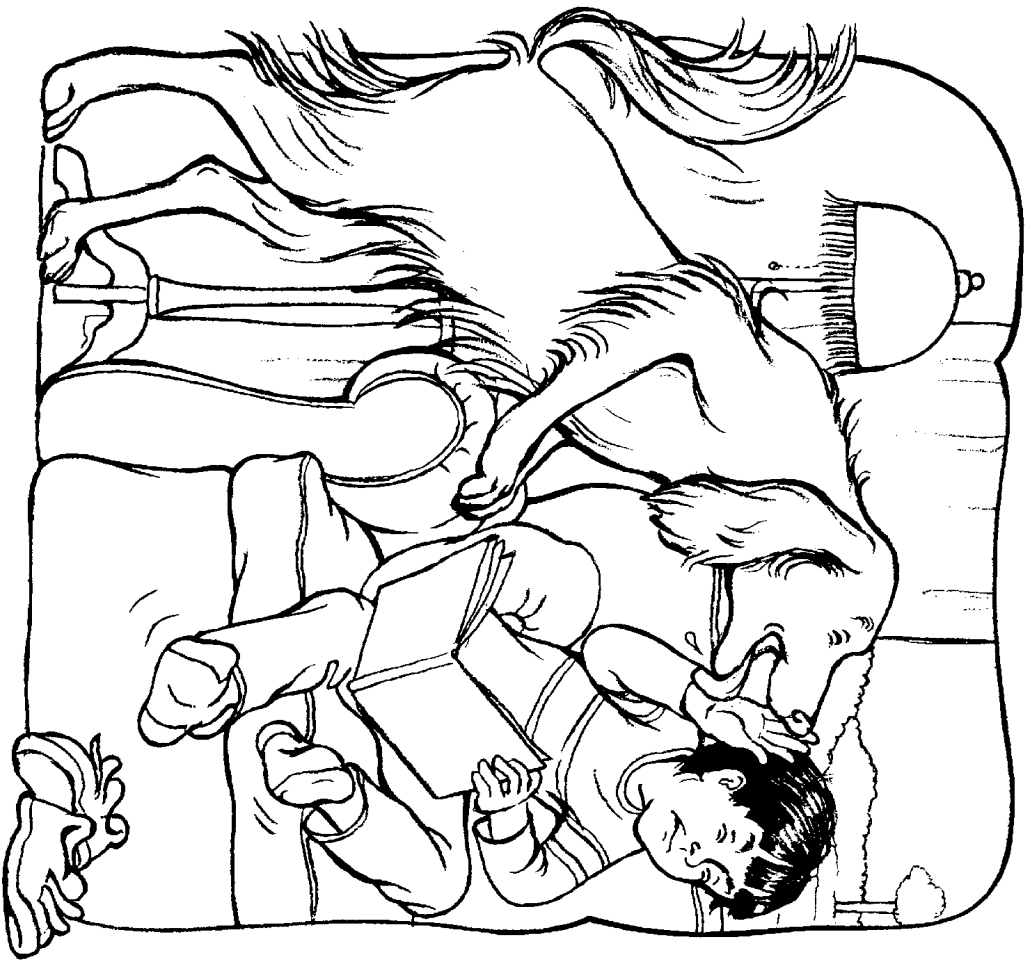

Rob licks Rick. Rick can't print.

4

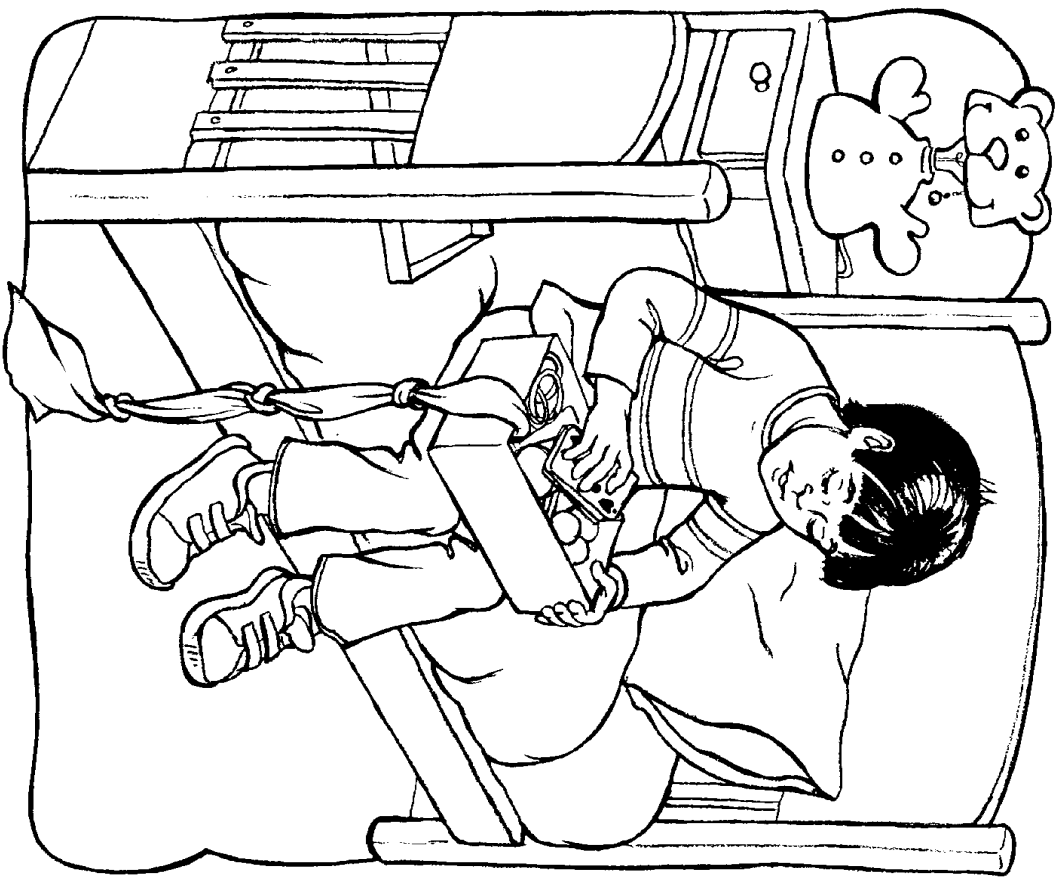

Rick sits and picks a trick.

5



The tall man trots past Cal and Kip.

# Cal and Kip

by Alex Yu  
illustrated by Kersti Frigell

Core Decodable 23



Bothell, WA • Chicago, IL • Columbus, OH • New York, NY



“It’s hot,” said Cal.

“Sip and drip a lot,” said Kip.

MHEonline.com



Copyright © 2015 McGraw-Hill Education

All rights reserved. The contents, or parts thereof, may be reproduced in print form for non-profit educational use with *SRA Open Court Reading*, provided such reproductions bear copyright notice, but may not be reproduced in any form for any other purpose without the prior written consent of McGraw-Hill Education, including, but not limited to, network storage or transmission, or broadcast for distance learning.

Send all inquiries to:  
 McGraw-Hill Education  
 8787 Orion Place  
 Columbus, OH 43240



The tall man had a sip.



A tall man is on the sand.



Bobcats spot the tall man.  
Cal and Kip Bobcat talk.



“And Bobcats skip snacks,” said Kip.





The tall man had a small snack.



“The sand is hot,” said Kip.





The tall man sat on a small rock.

6



“Bobcats can’t have backpacks,” said Cal.

11



The tall man had a backpack.



The tall man had a black cap.



"Can I have a cap?" said Cal.

8



"Bobcats can't have caps," said Kip.

9



A bobcat sprints fast!

# Bobcat

by Robert Bridges  
illustrated by Meryl Henderson

Core Decodable 24



Bothell, WA • Chicago, IL • Columbus, OH • New York, NY



MHEonline.com



Copyright © 2015 McGraw-Hill Education

All rights reserved. The contents, or parts thereof, may be reproduced in print form for non-profit educational use with *SRA Open Court Reading*, provided such reproductions bear copyright notice, but may not be reproduced in any form for any other purpose without the prior written consent of McGraw-Hill Education, including, but not limited to, network storage or transmission, or broadcast for distance learning.

Send all inquiries to:  
McGraw-Hill Education  
8787 Orion Place  
Columbus, OH 43240

2



Look! A bobcat can stand stiff.

7



A bobcat can look fast.



Look! A bobcat is on a cliff.  
It sits on a flat rock.





Can it look at the fat rabbit?

4

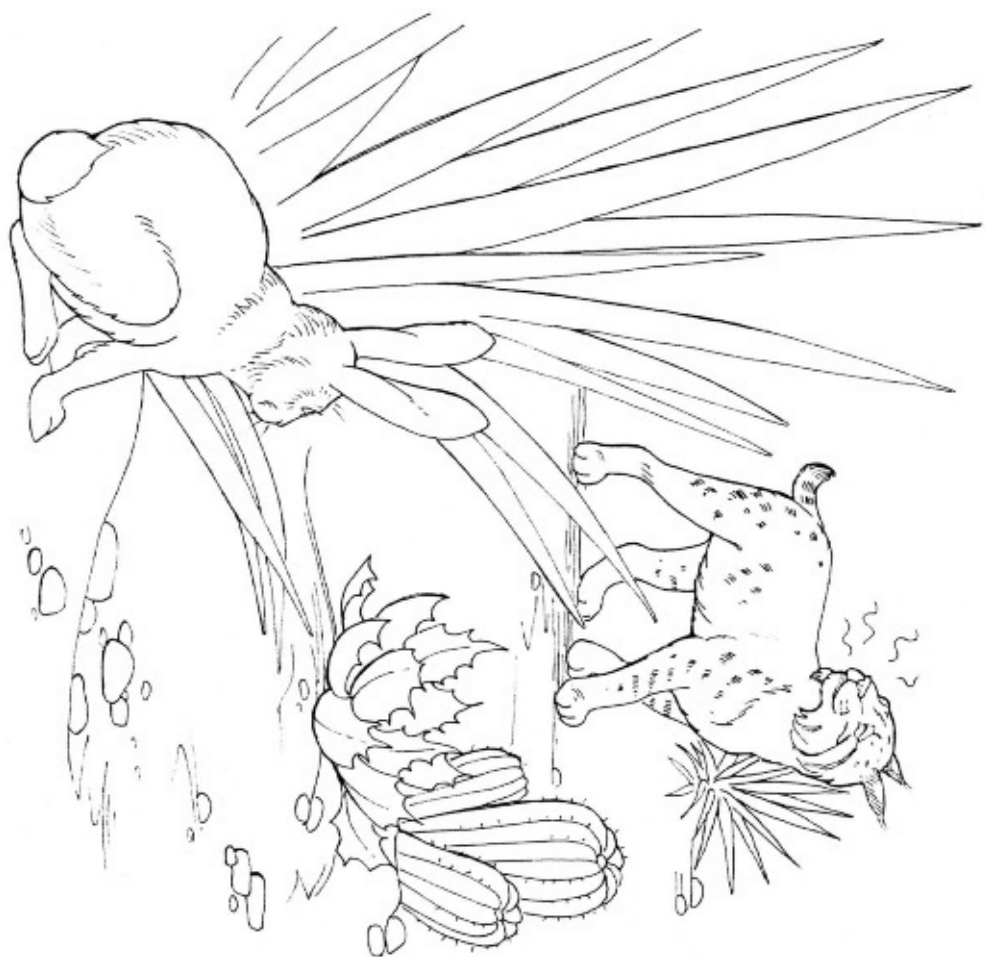

A bobcat sniffs a rabbit.

5

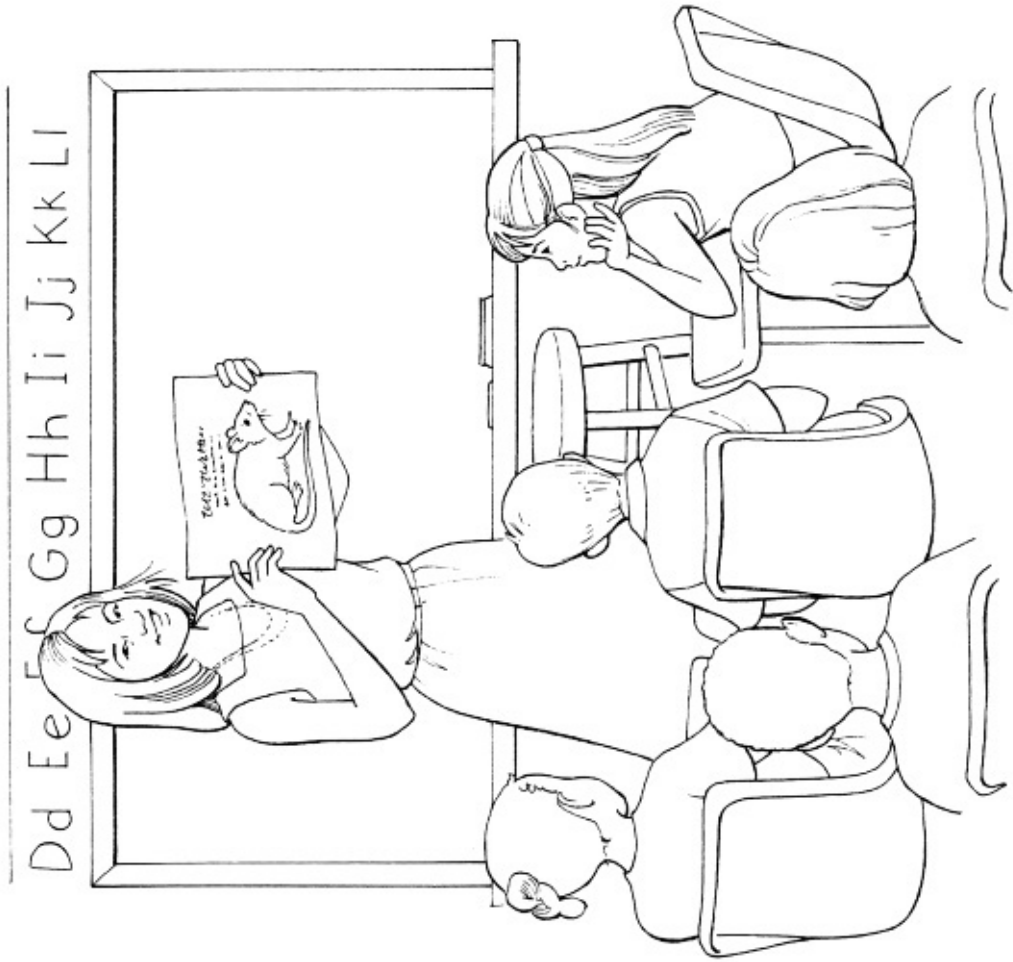

Pat's class was back.

Pat's class trip was a blast!

# Pat's Class Trip

by Jessica Evans  
illustrated by Meryl Henderson

Core Decodable 25



Bothell, WA • Chicago, IL • Columbus, OH • New York, NY

MHEonline.com



Copyright © 2015 McGraw-Hill Education

All rights reserved. The contents, or parts thereof, may be reproduced in print form for non-profit educational use with *SRA Open Court Reading*, provided such reproductions bear copyright notice, but may not be reproduced in any form for any other purpose without the prior written consent of McGraw-Hill Education, including, but not limited to, network storage or transmission, or broadcast for distance learning.

Send all inquiries to:  
McGraw-Hill Education  
8787 Orion Place  
Columbus, OH 43240

2

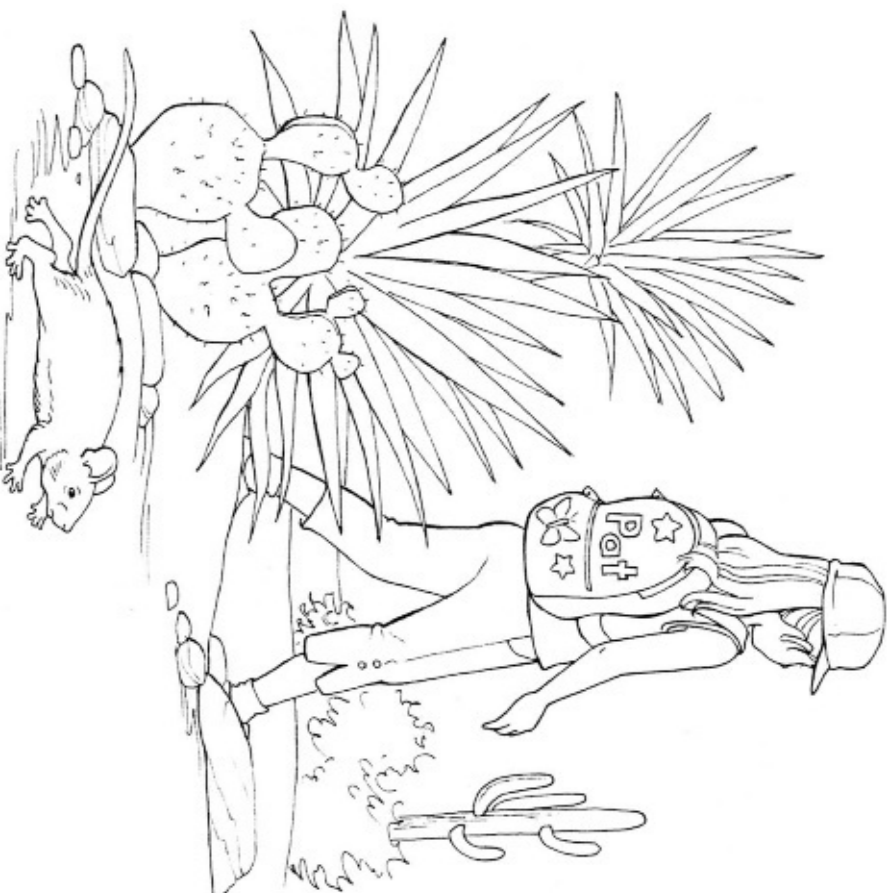

What ran fast?

A rat did pass Pat's class.

7



What can hop past?



Pat's class was on a trip.





It was hot in the sand.

4

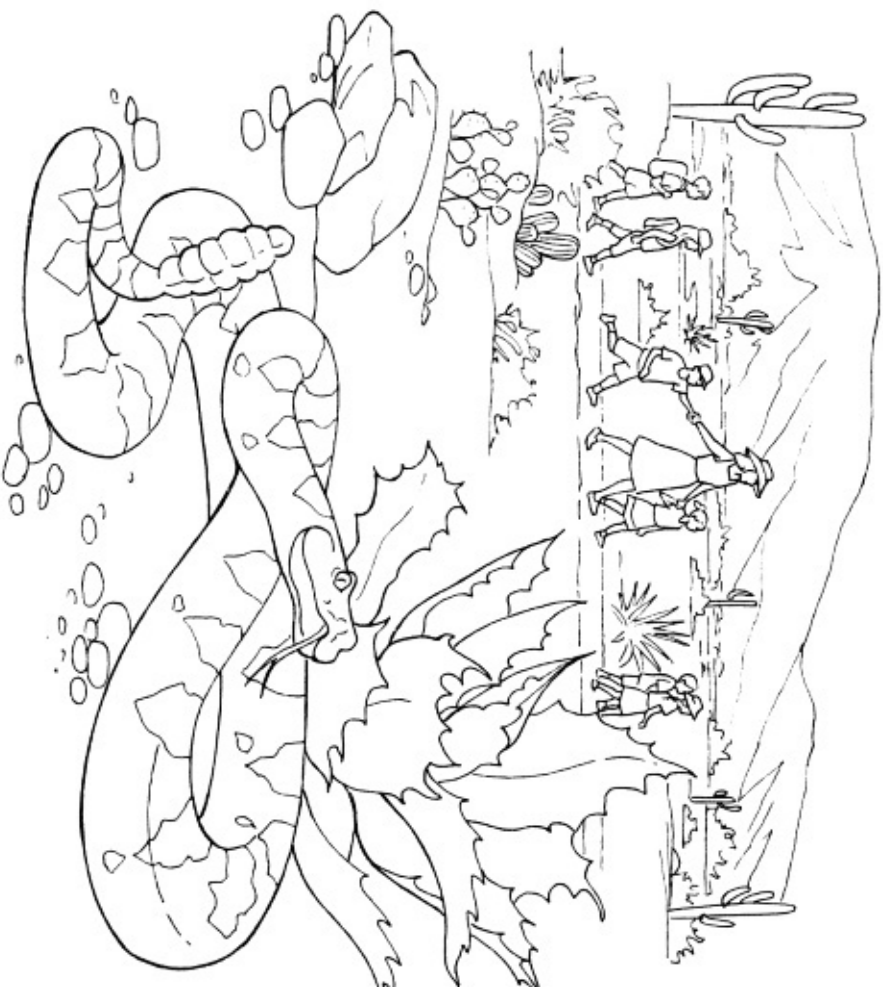

What did Pat's class miss?

What can hiss?

5



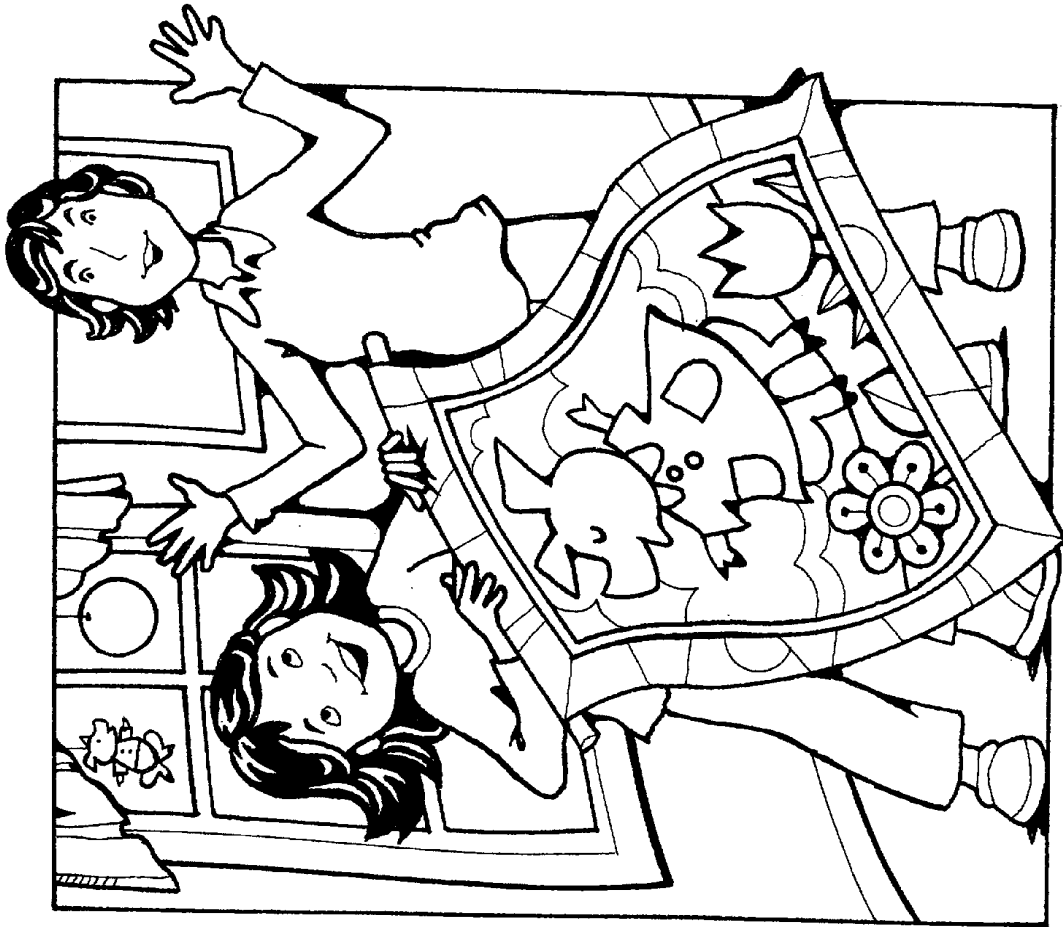

Mom got a pig gift.  
It was a pig flag.

# Rag Bits

by Greg Frazier  
illustrated by Olivia Cole

Core Decodable 26



Bothell, WA • Chicago, IL • Columbus, OH • New York, NY

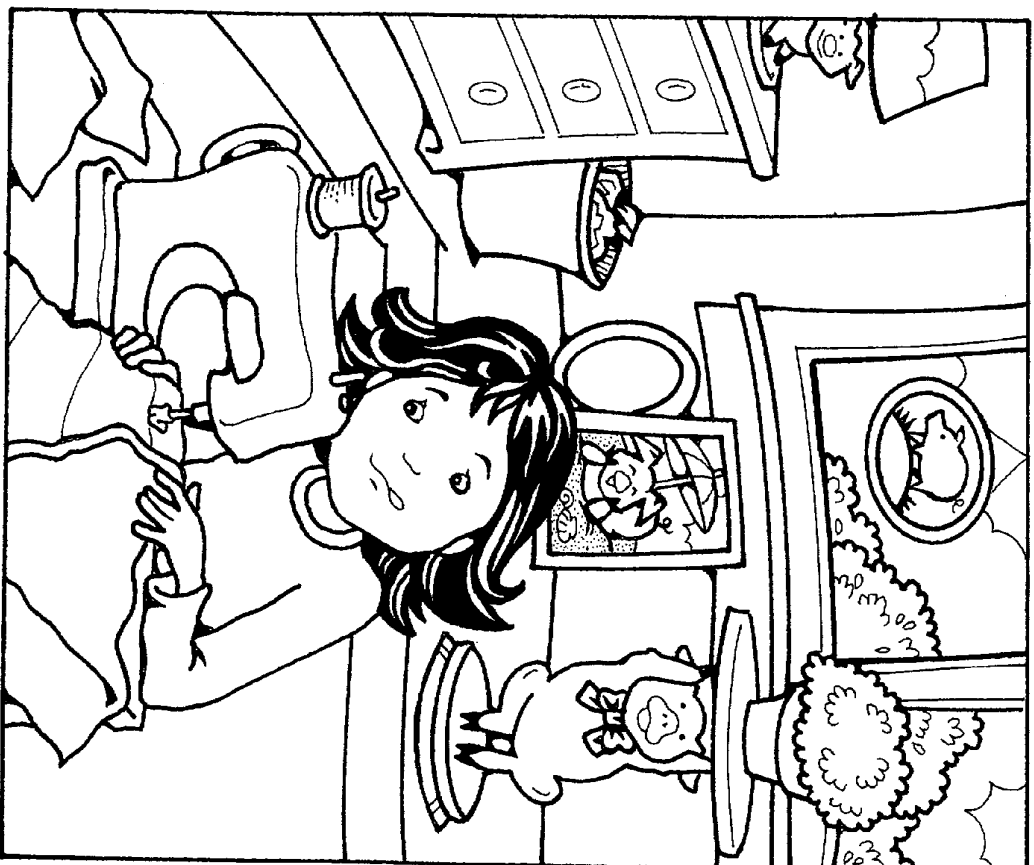

Mom was a pig fan.  
Nan had a rag gift.

MHEonline.com



Copyright © 2015 McGraw-Hill Education

All rights reserved. The contents, or parts thereof, may be reproduced in print form for non-profit educational use with *SRA Open Court Reading*, provided such reproductions bear copyright notice, but may not be reproduced in any form for any other purpose without the prior written consent of McGraw-Hill Education, including, but not limited to, network storage or transmission, or broadcast for distance learning.

Send all inquiries to:  
McGraw-Hill Education  
8787 Orion Place  
Columbus, OH 43240

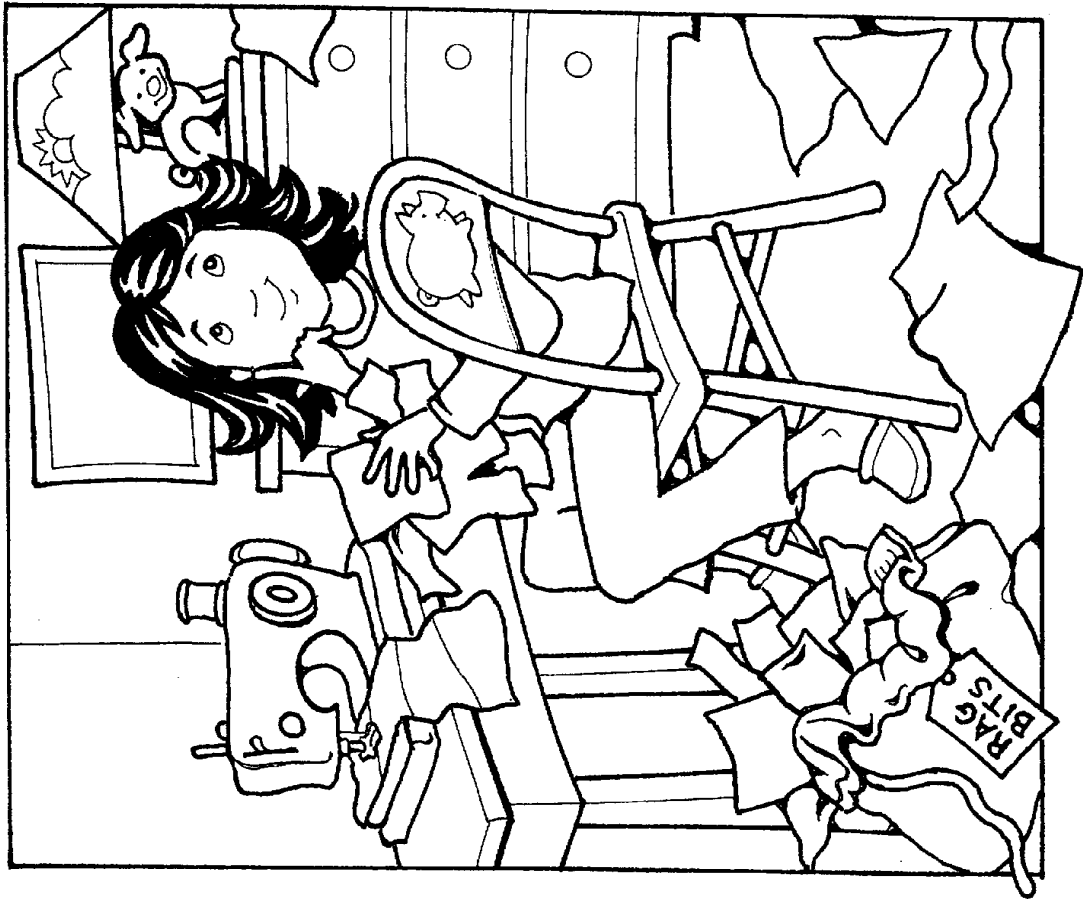

Nan had a plan.  
Nan got the bag.

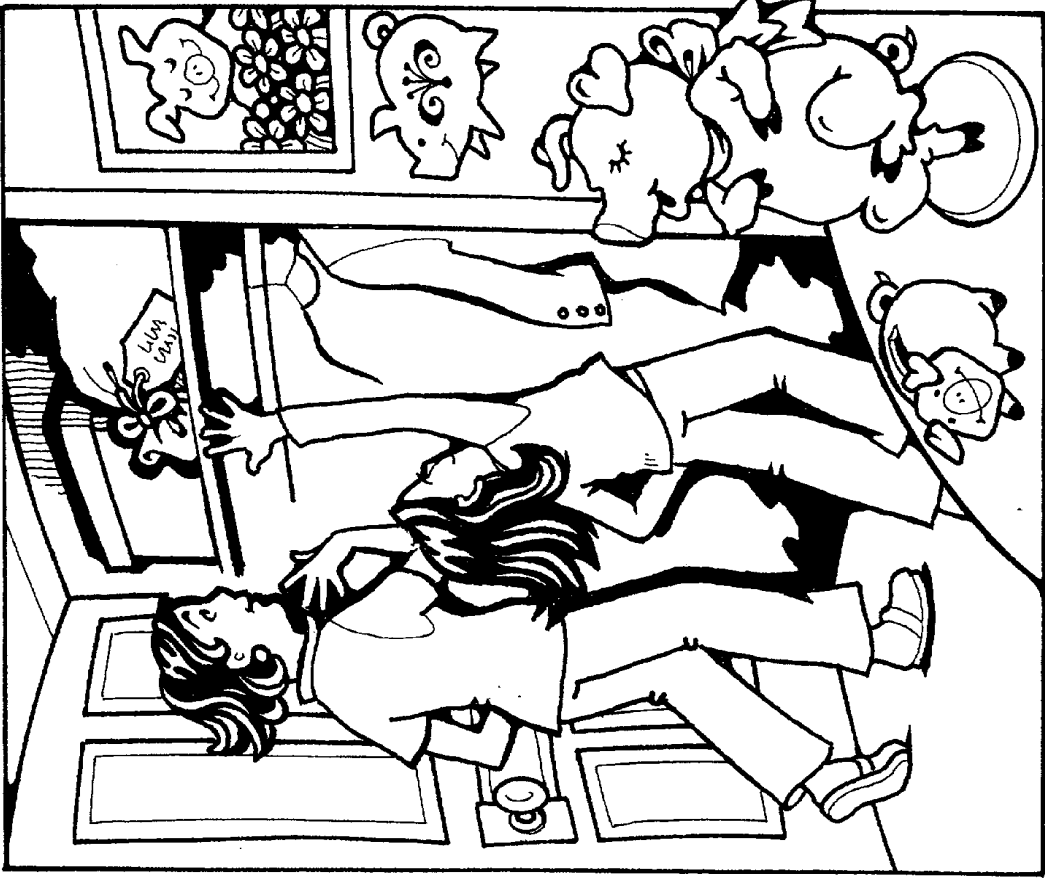

Mom had a big bag.



The bag had a tag.

4

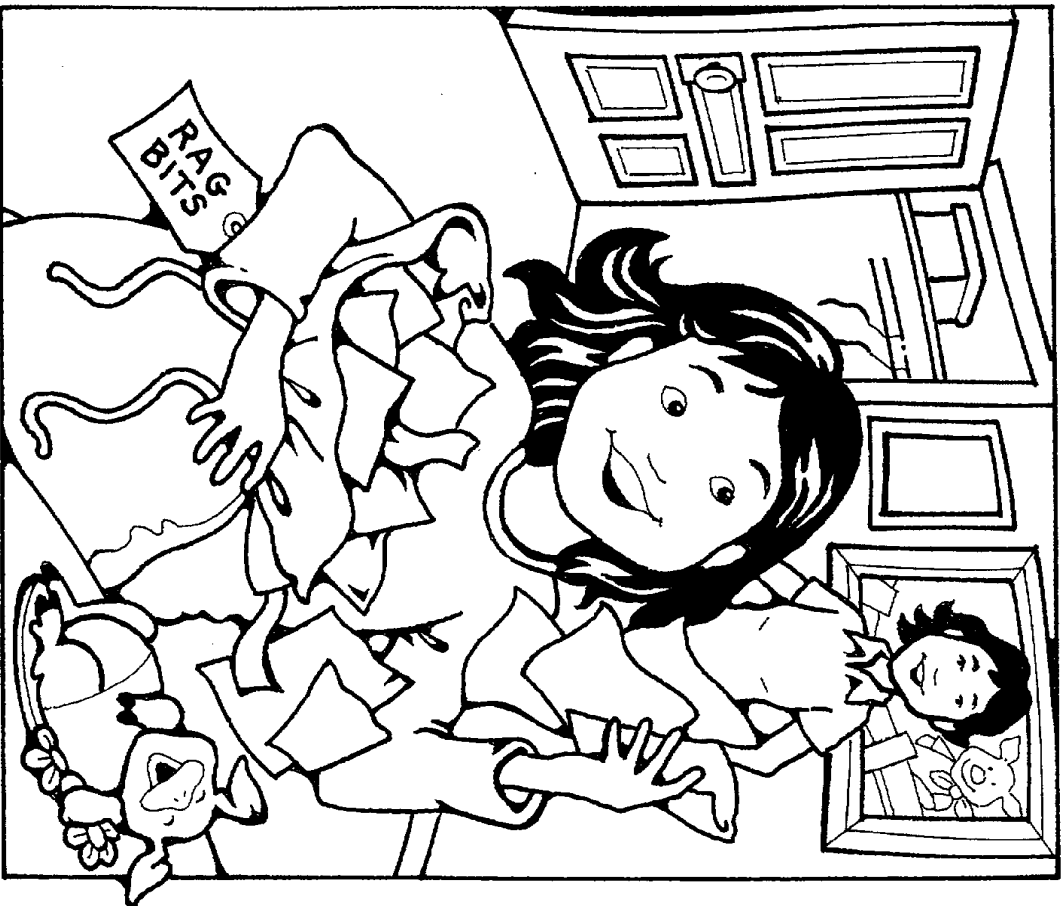

"Grab the bag and look," said Mom.

5

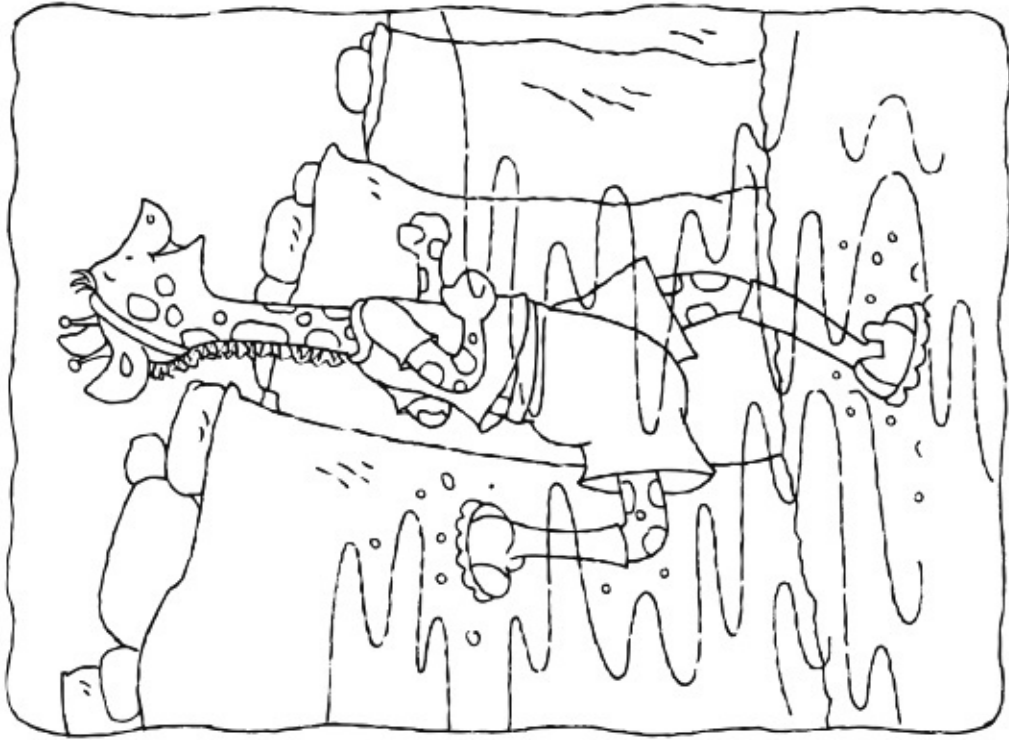

Jill can jog!

Jill can see in the fog!

# A Jog in Fog

by Jesse Griffin  
illustrated by C. A. Nobens

Core Decodable 27



Bothell, WA • Chicago, IL • Columbus, OH • New York, NY



MHEonline.com



Copyright © 2015 McGraw-Hill Education

All rights reserved. The contents, or parts thereof, may be reproduced in print form for non-profit educational use with SRA Open Court Reading, provided such reproductions bear copyright notice, but may not be reproduced in any form for any other purpose without the prior written consent of McGraw-Hill Education, including, but not limited to, network storage or transmission, or broadcast for distance learning.

Send all inquiries to:  
McGraw-Hill Education  
8787 Orion Place  
Columbus, OH 43240

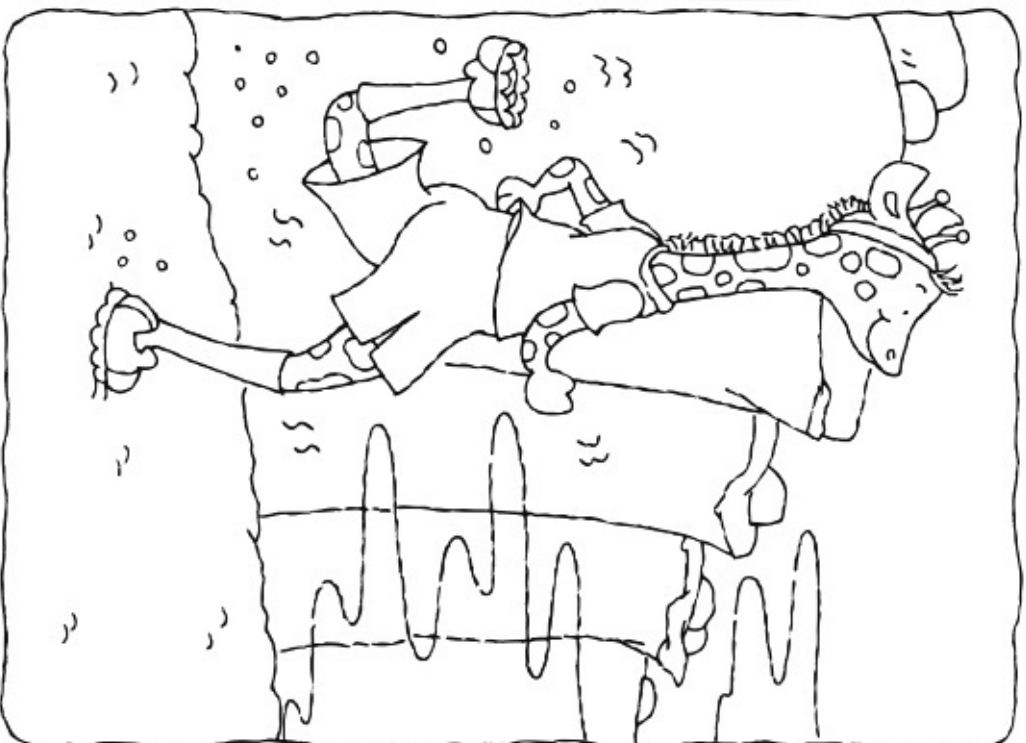

Jill is at the rocks.  
Can Jill jog?

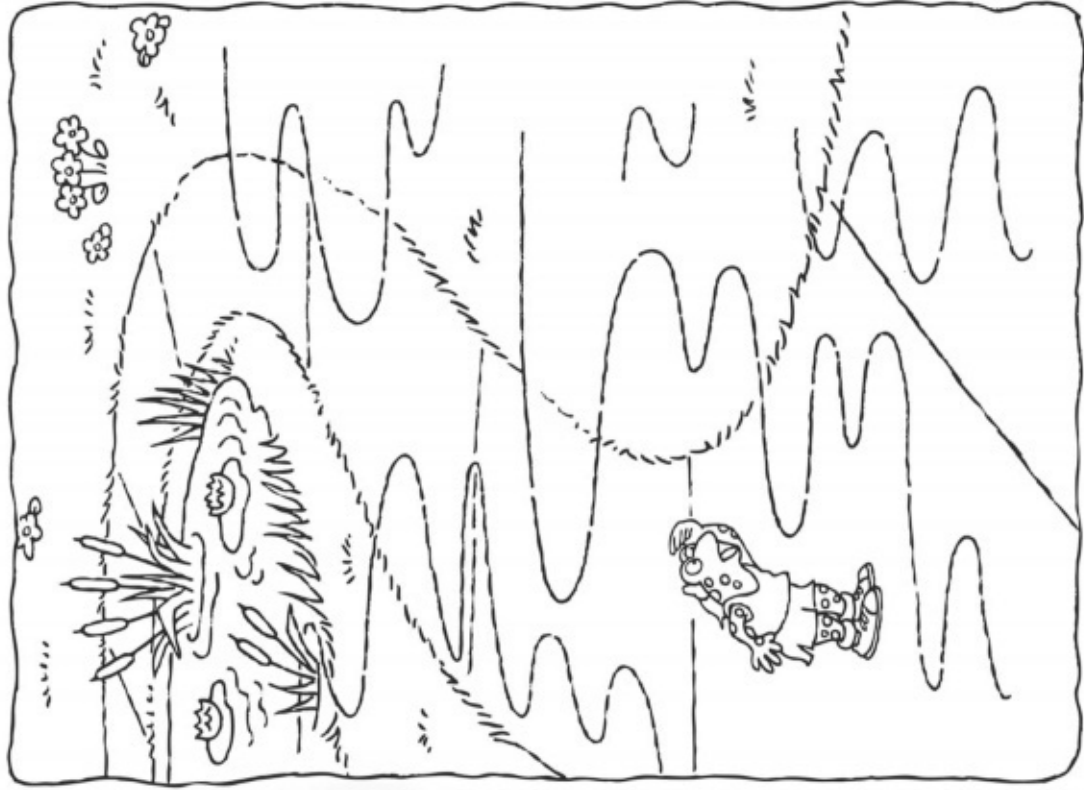

Jan cannot jog in fog.

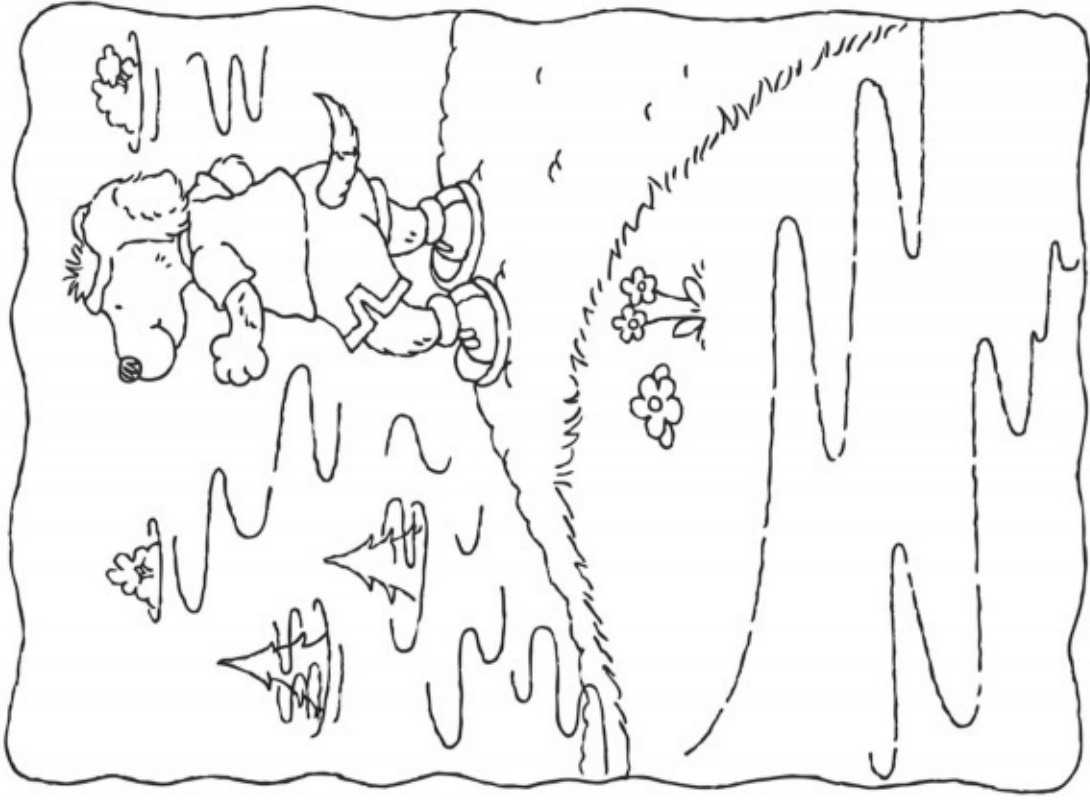

Jack is a dog on a hilltop.

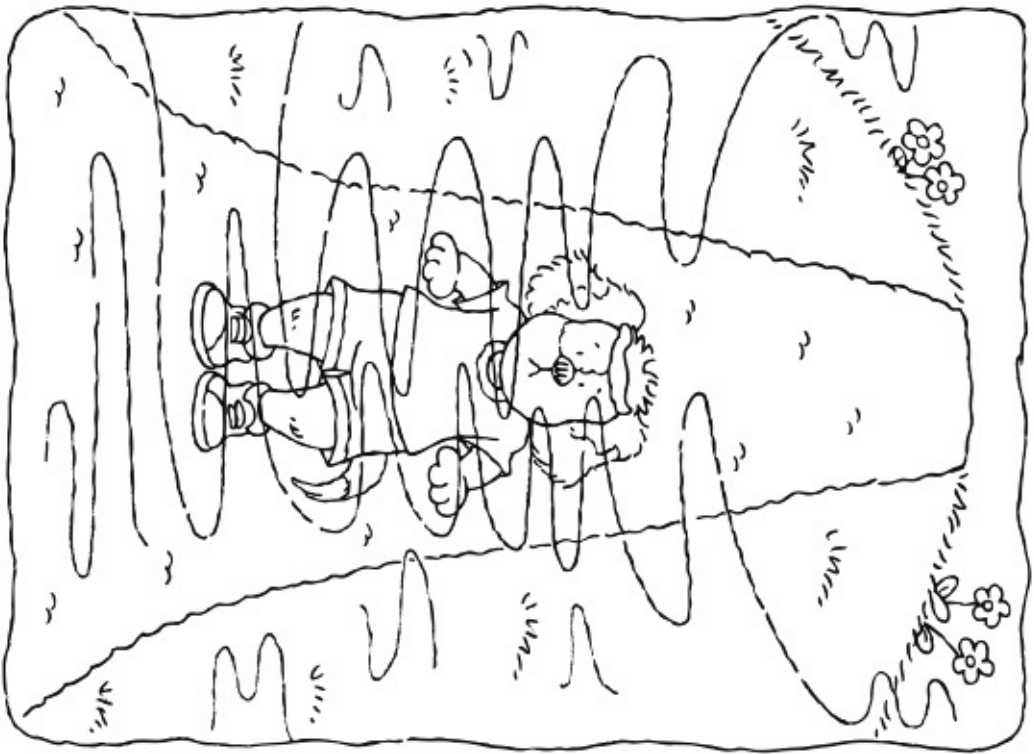

Jack cannot jog.

Jack cannot see in fog.

4

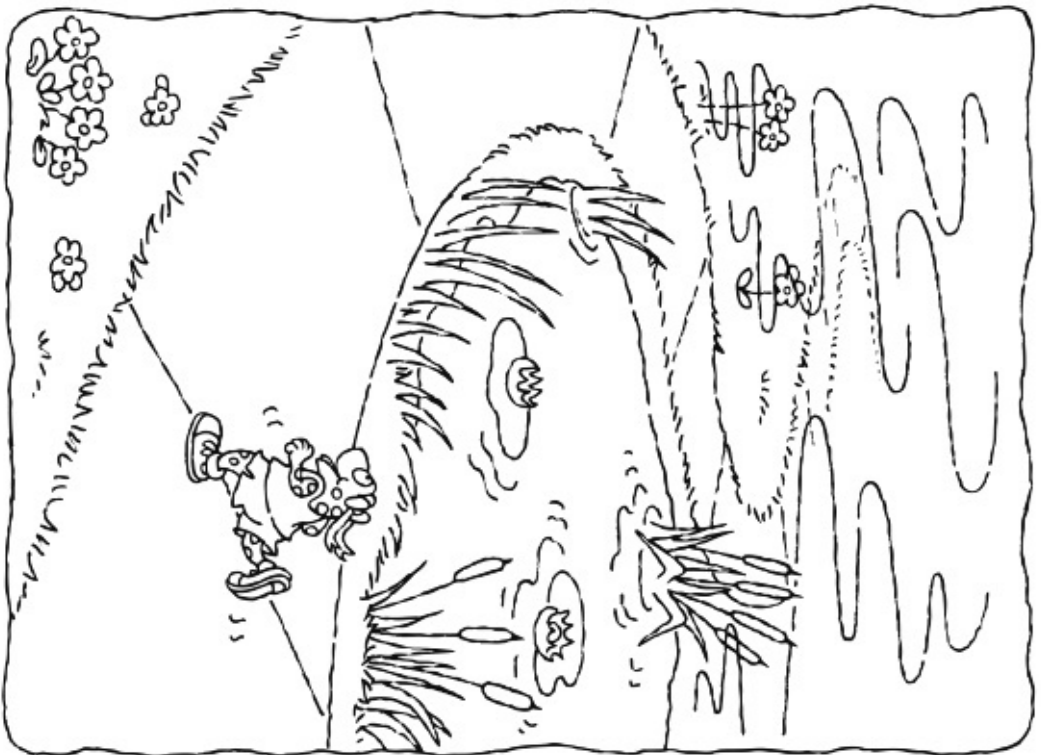

Jan is a frog at a pond.

5

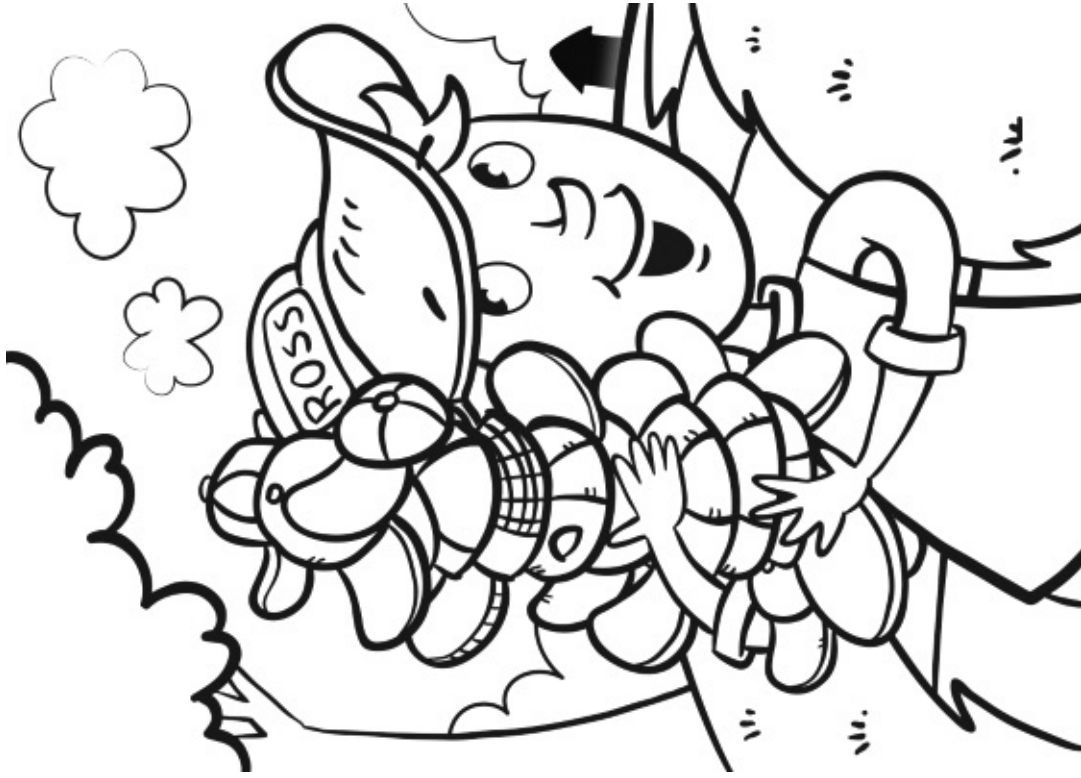

Ross is a big cap fan!

# A Cap Fan

by Gavin Hoffman  
illustrated by Merrill Rainey

Core Decodable 28



Bothell, WA • Chicago, IL • Columbus, OH • New York, NY

MHEonline.com



Copyright © 2015 McGraw-Hill Education

All rights reserved. The contents, or parts thereof, may be reproduced in print form for non-profit educational use with *SRA Open Court Reading*, provided such reproductions bear copyright notice, but may not be reproduced in any form for any other purpose without the prior written consent of McGraw-Hill Education, including, but not limited to, network storage or transmission, or broadcast for distance learning.

Send all inquiries to:  
 McGraw-Hill Education  
 8787 Orion Place  
 Columbus, OH 43240

2



Got caps? Call Ross!

Ross can pick the caps up.

15



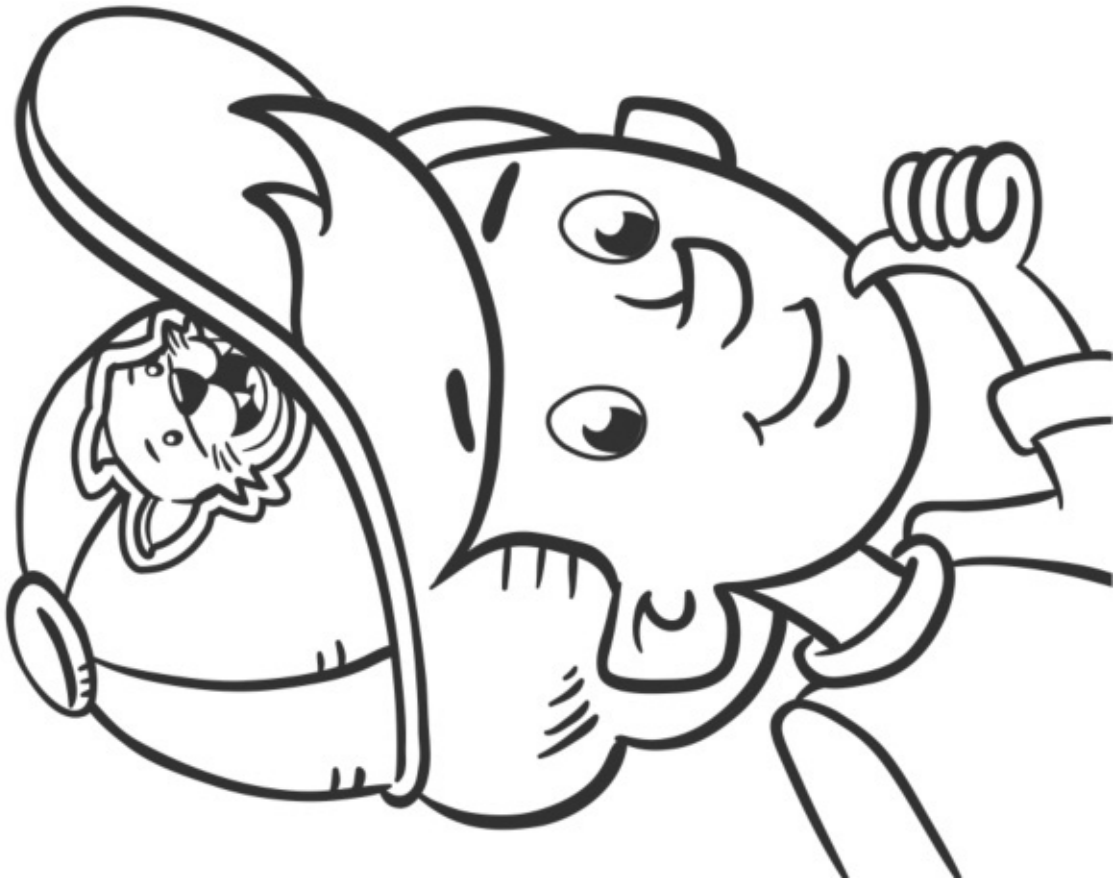

Ross has on a Bobcat cap.



If a cap rips, Ross still has it.

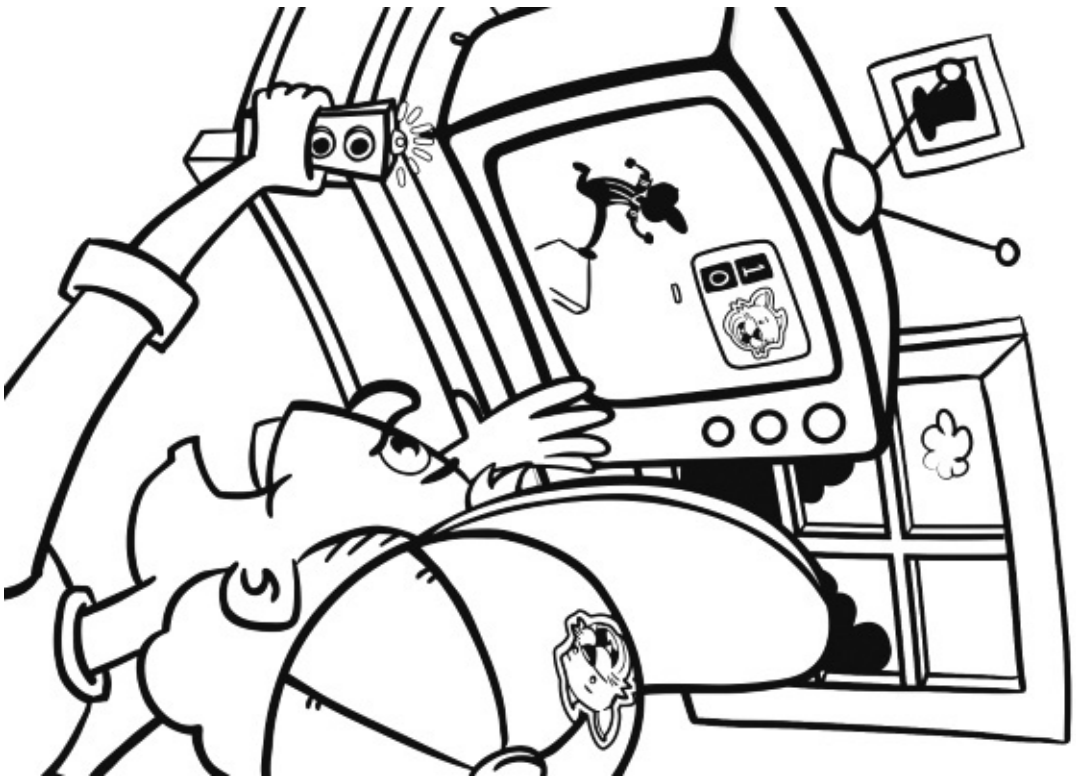

Is Ross a Bobcat fan?

4

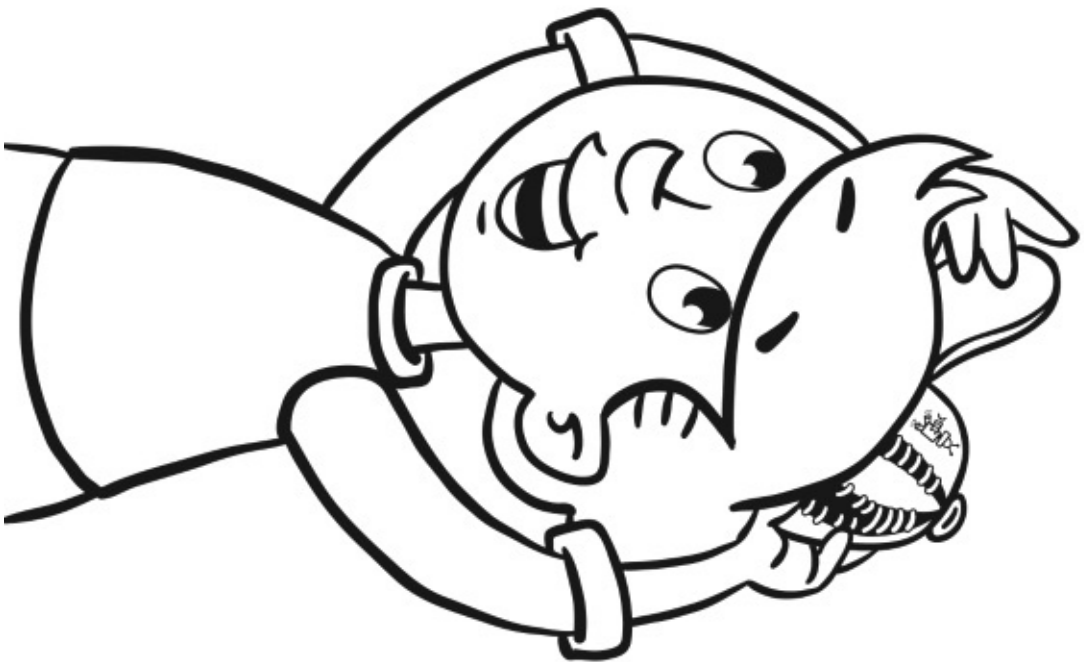

Ross can jam on the tan cap.

13

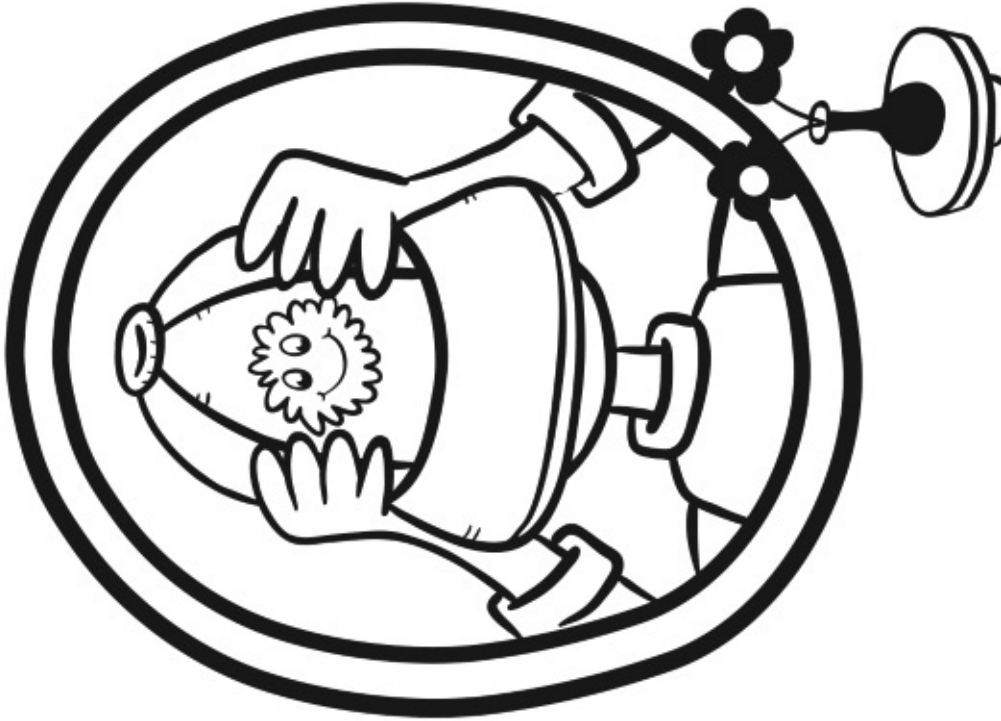

The black cap was big.  
Ross still has it.

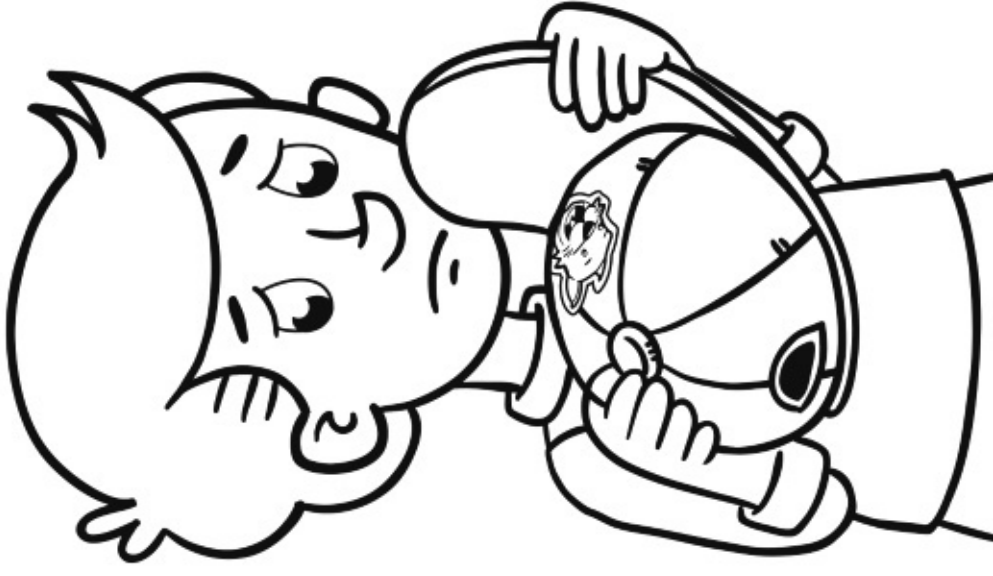

Ross is not a big Bobcat fan.

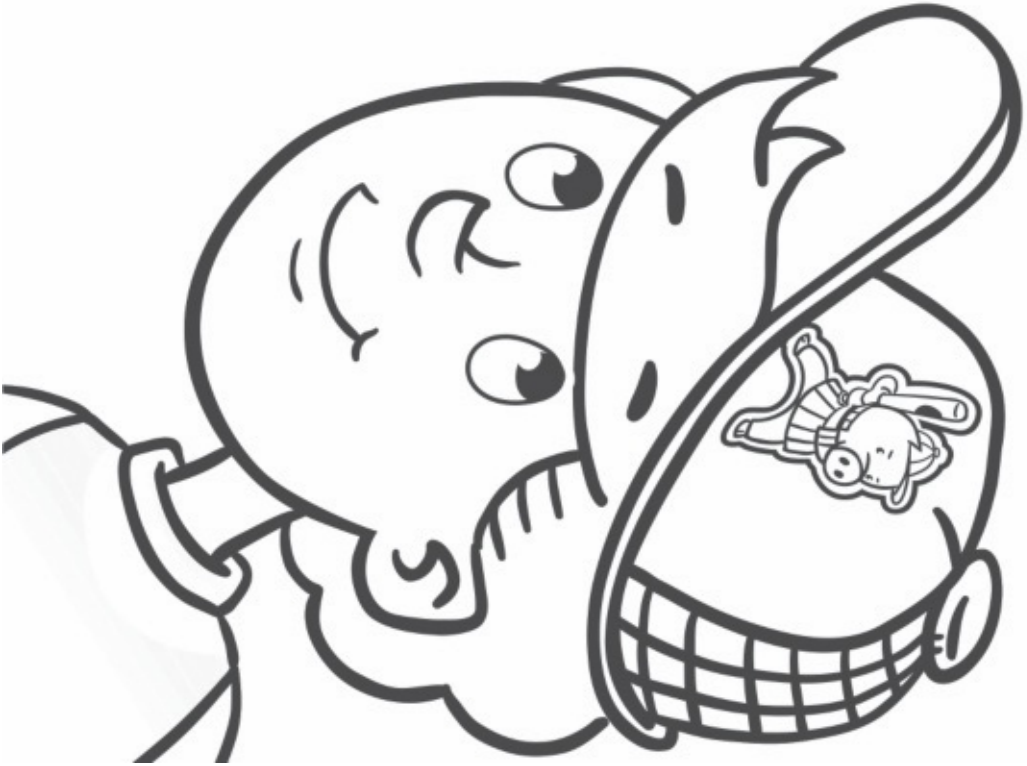

Ross is a big cap fan.

6

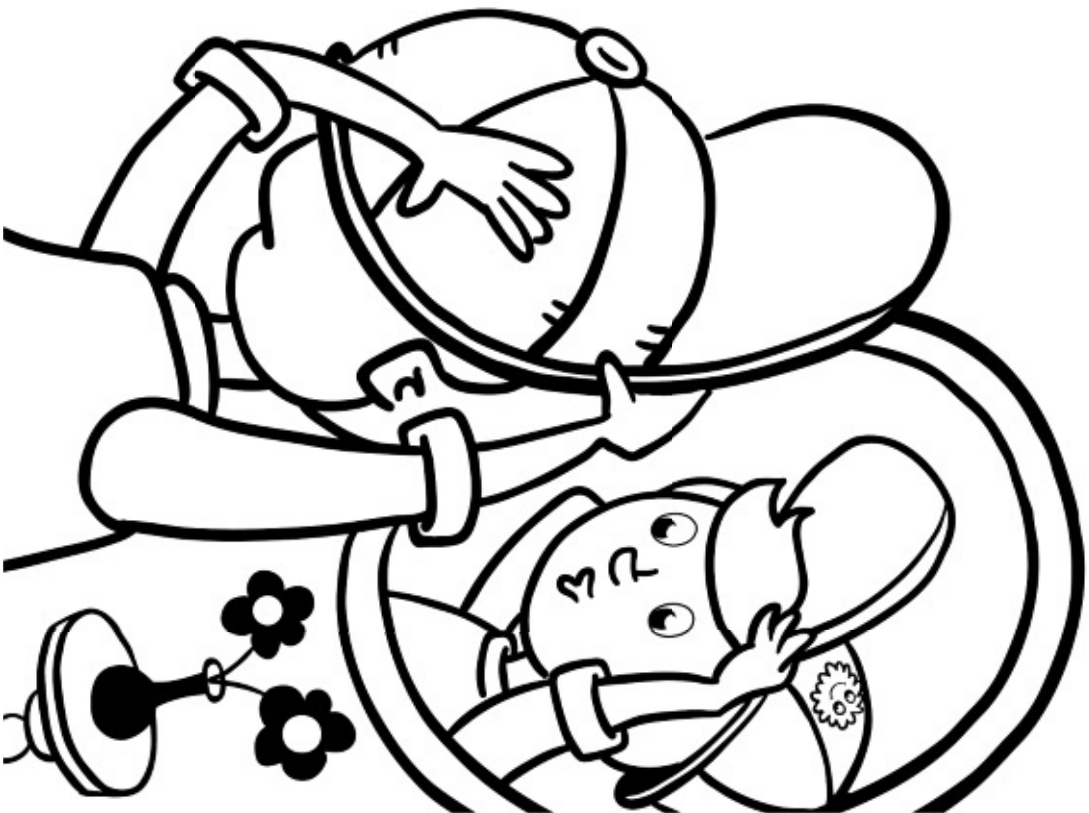

Not all caps fit Ross.

11





Ross sticks soft caps in a bag.

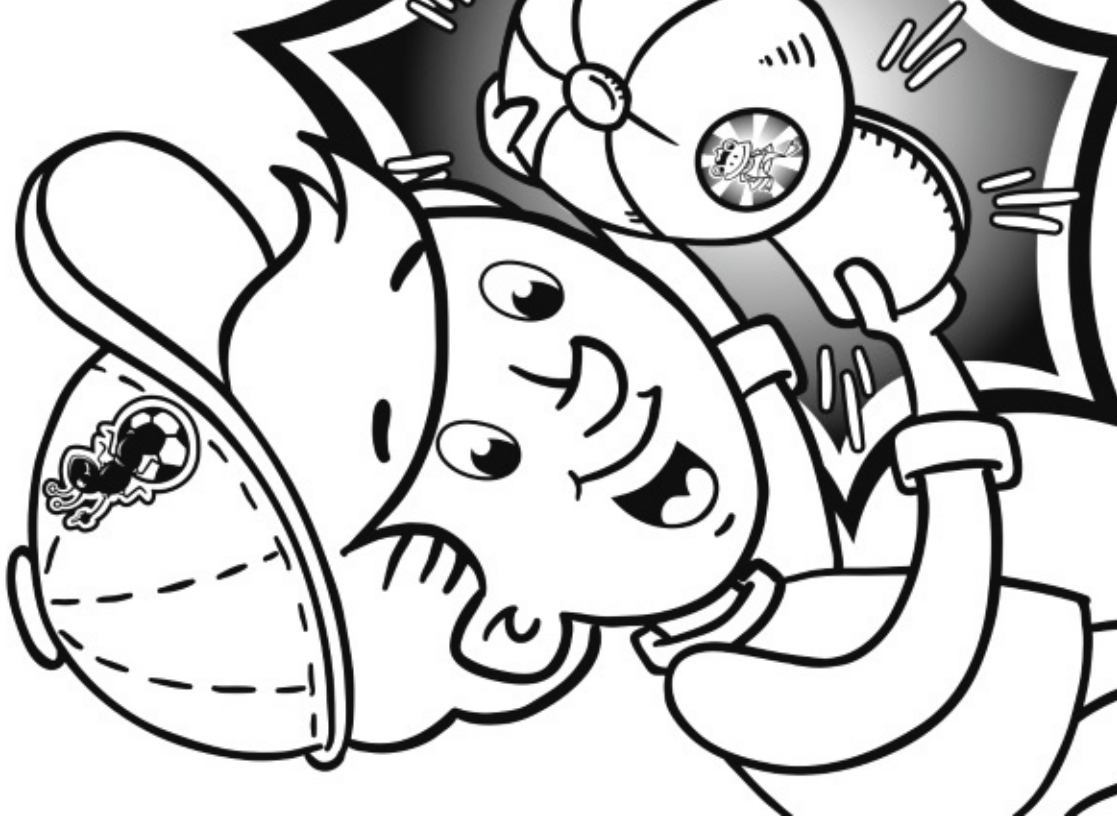

Ross has Pig, Ants, and Frog caps.



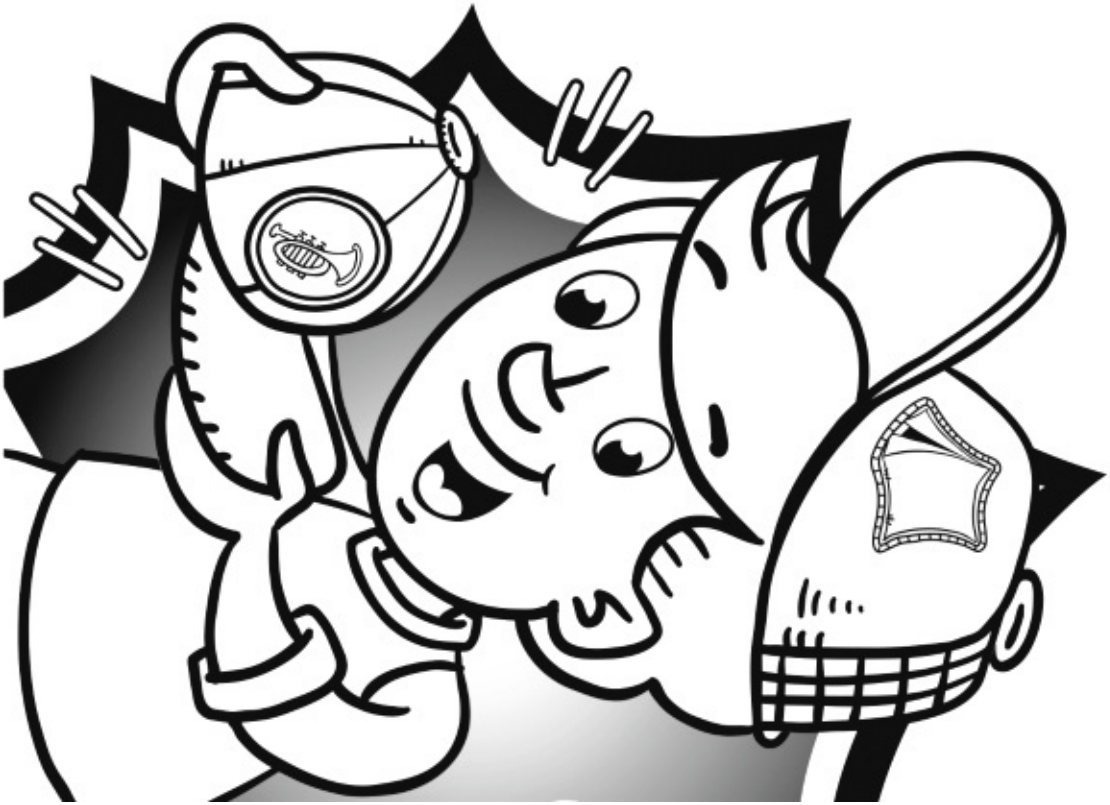

Ross has camp and band caps.

8

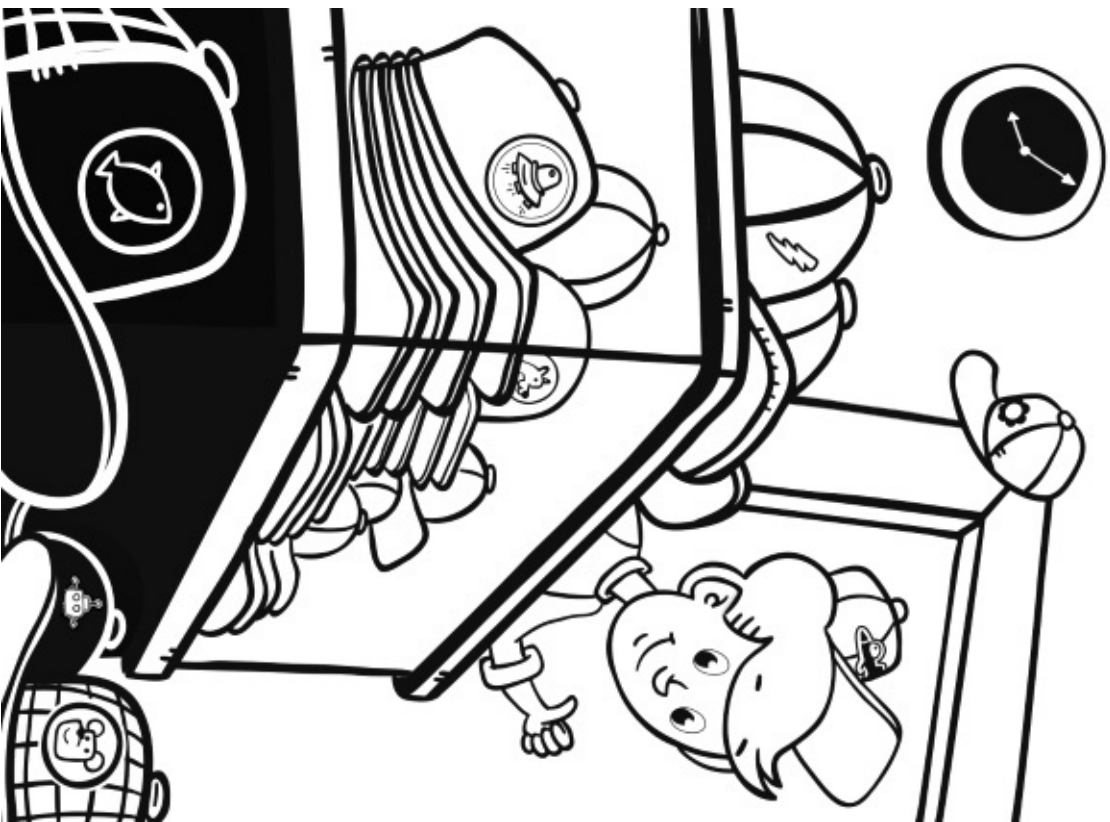

Ross stacks stiff caps in glass.

9

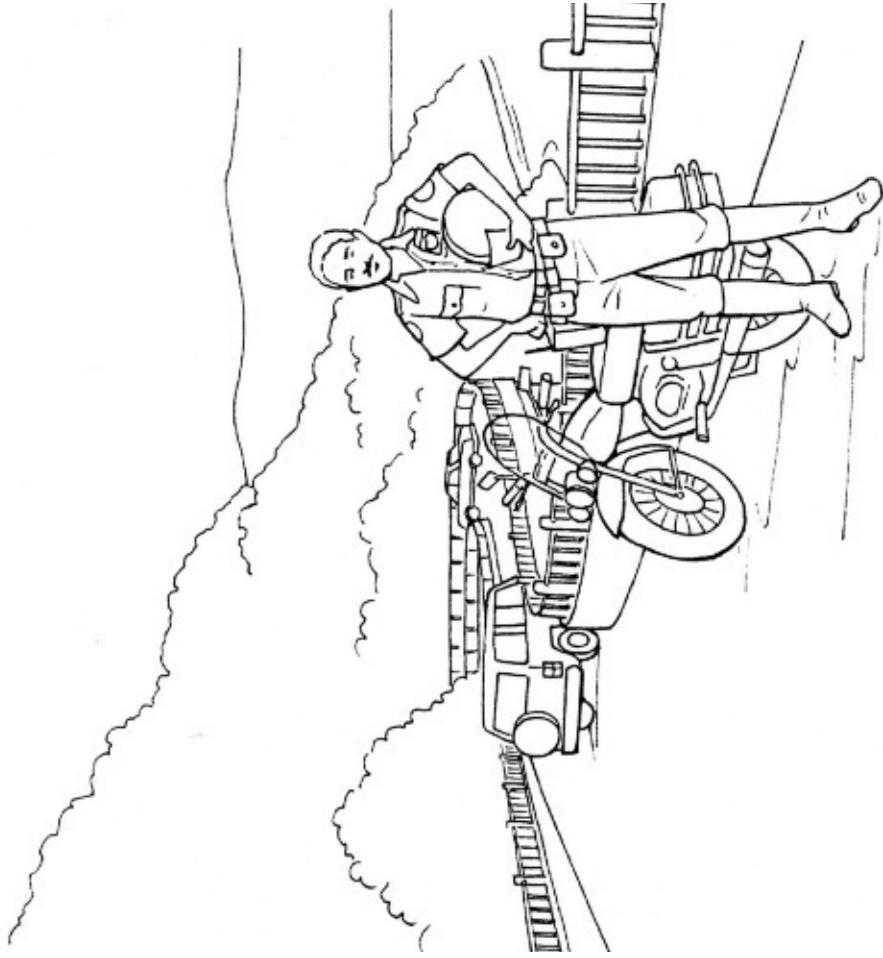

# Jack's Job

by Robert Bridges  
illustrated by Meryl Henderson

Core Decodable 29



Bothell, WA • Chicago, IL • Columbus, OH • New York, NY

Jack got the bridge traffic to pass.

MHEonline.com



Copyright © 2015 McGraw-Hill Education

All rights reserved. The contents, or parts thereof, may be reproduced in print form for non-profit educational use with *SRA Open Court Reading*, provided such reproductions bear copyright notice, but may not be reproduced in any form for any other purpose without the prior written consent of McGraw-Hill Education, including, but not limited to, network storage or transmission, or broadcast for distance learning.

Send all inquiries to:  
McGraw-Hill Education  
8787 Orion Place  
Columbus, OH 43240

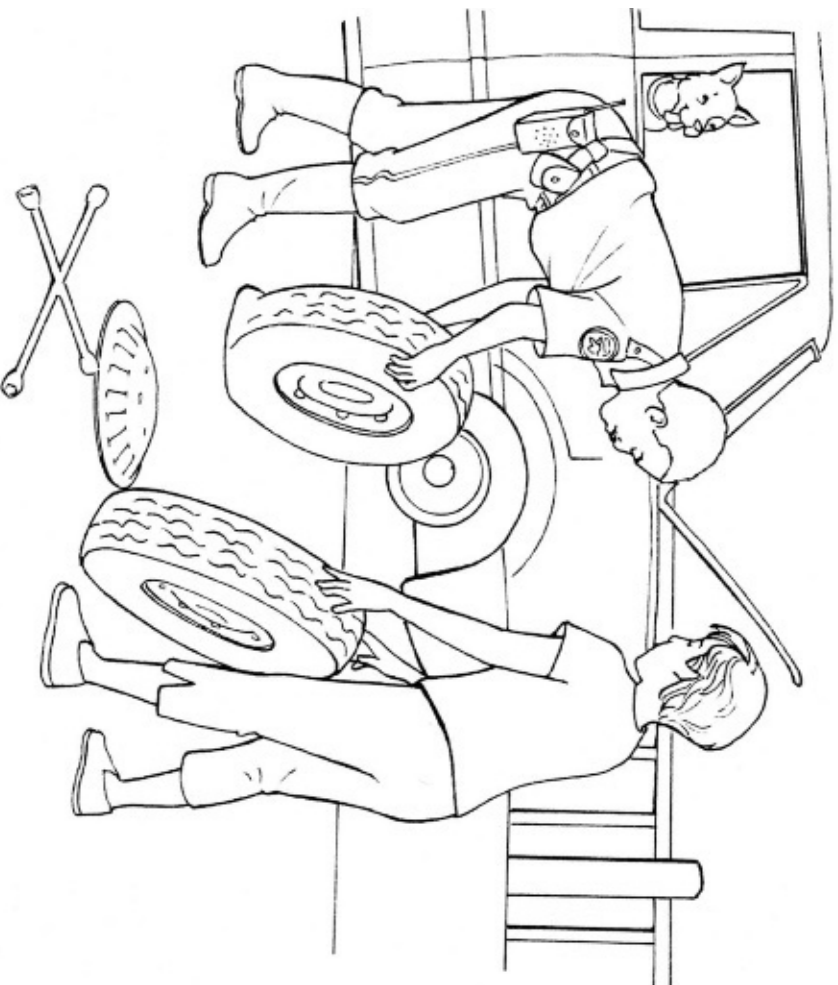

Bridge traffic had to pass.

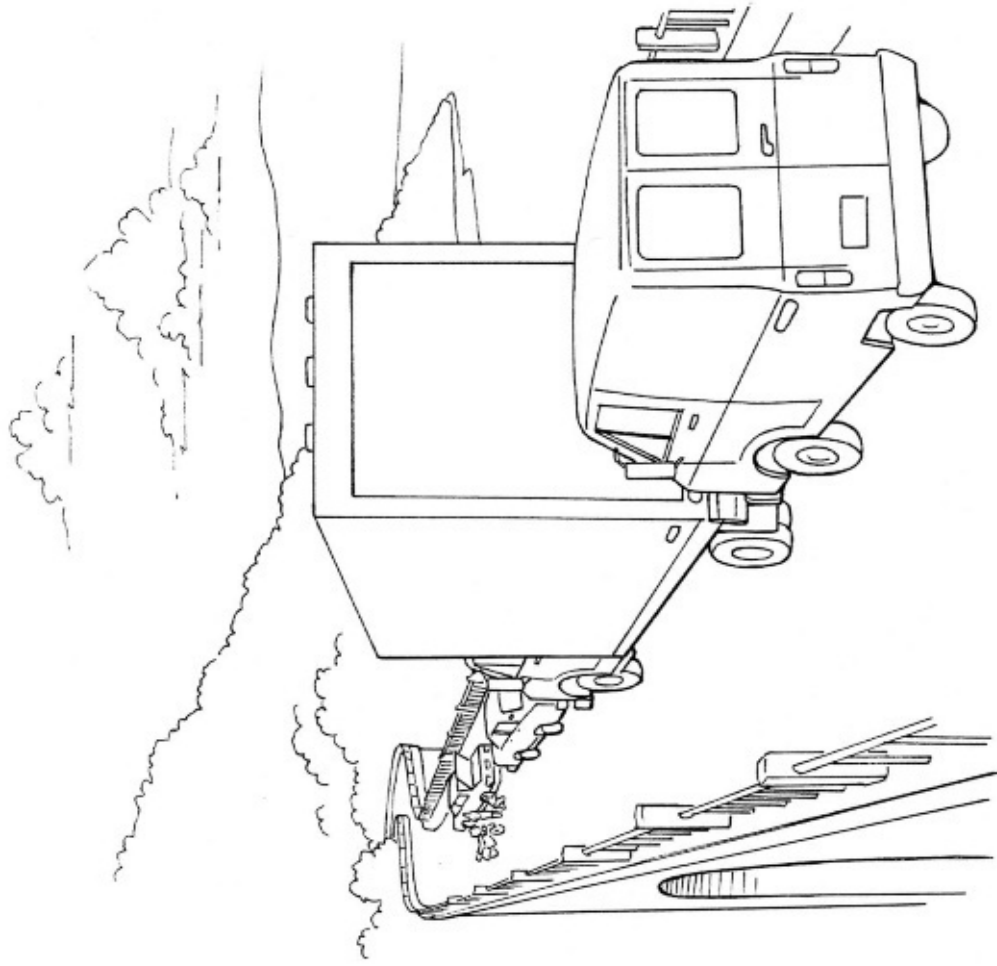

Traffic did not pass Jan.  
It had to stop.



Jack's job had a badge.



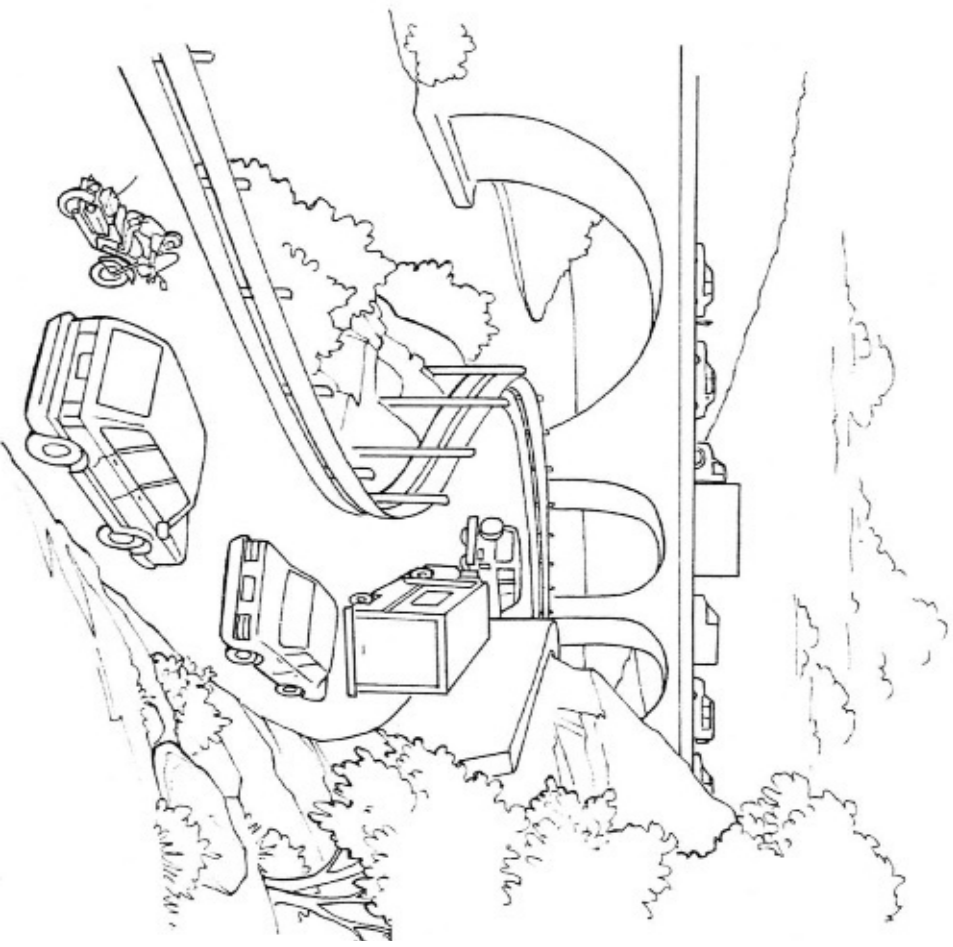

The bridge had a traffic jam.

Jack had to act fast.

4

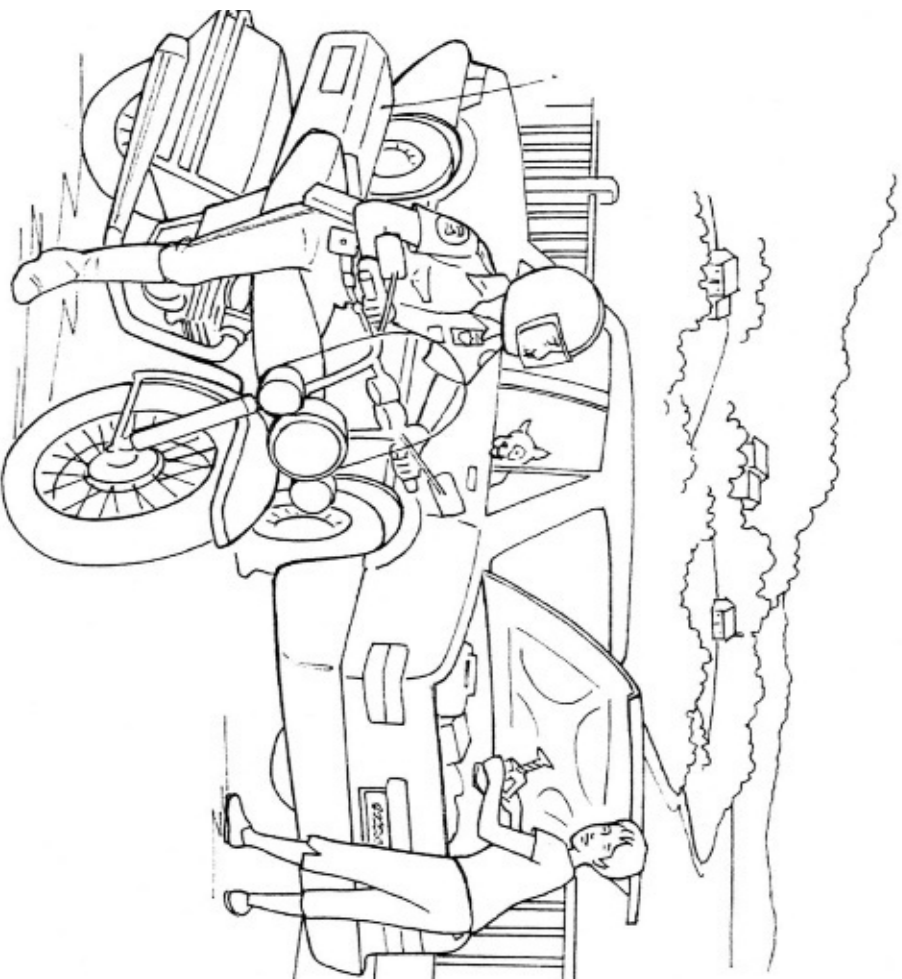

Jan had a flat on the bridge.

5





# Plum Pond

by Bud Hamilton  
illustrated by Deborah Colvin Borgo

Core Decodable 30



Bothell, WA • Chicago, IL • Columbus, OH • New York, NY

Plum Pond is fun!

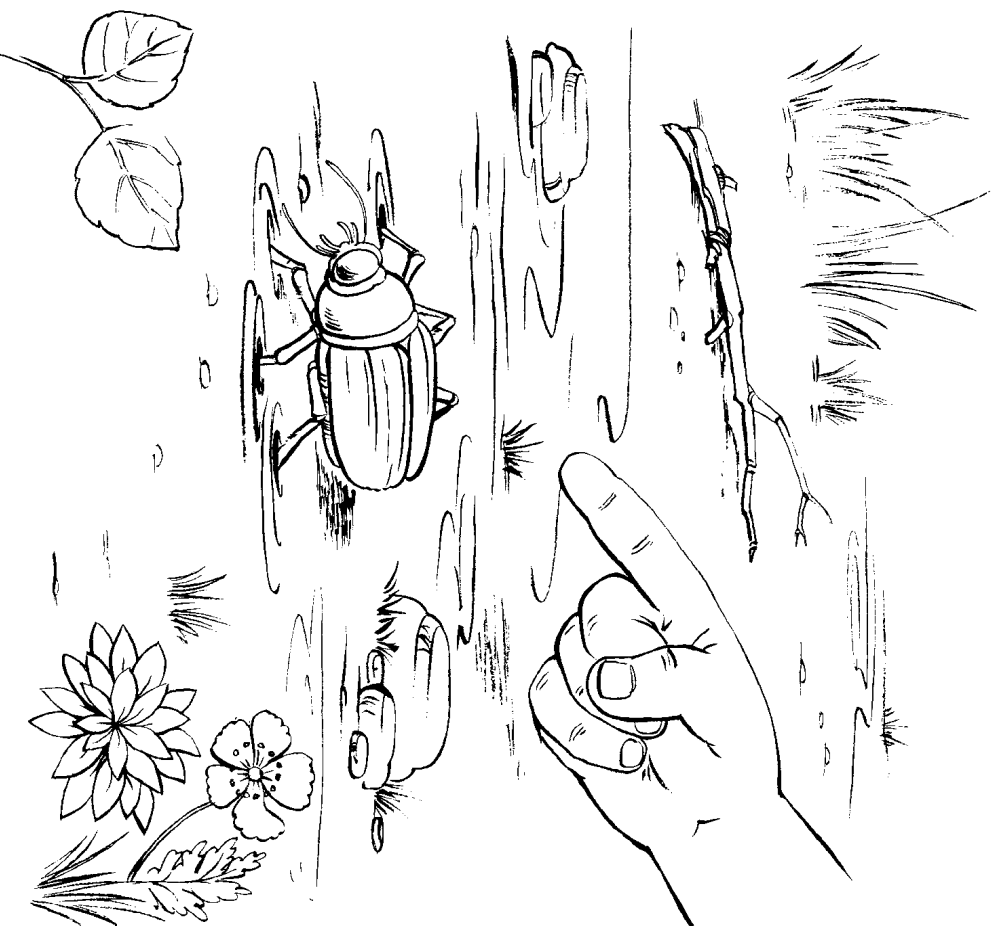

A big bug sat in mud.  
“Did it get stuck?” said Jill.

MHEonline.com



Copyright © 2015 McGraw-Hill Education

All rights reserved. The contents, or parts thereof, may be reproduced in print form for non-profit educational use with *SRA Open Court Reading*, provided such reproductions bear copyright notice, but may not be reproduced in any form for any other purpose without the prior written consent of McGraw-Hill Education, including, but not limited to, network storage or transmission, or broadcast for distance learning.

Send all inquiries to:  
McGraw-Hill Education  
8787 Orion Place  
Columbus, OH 43240

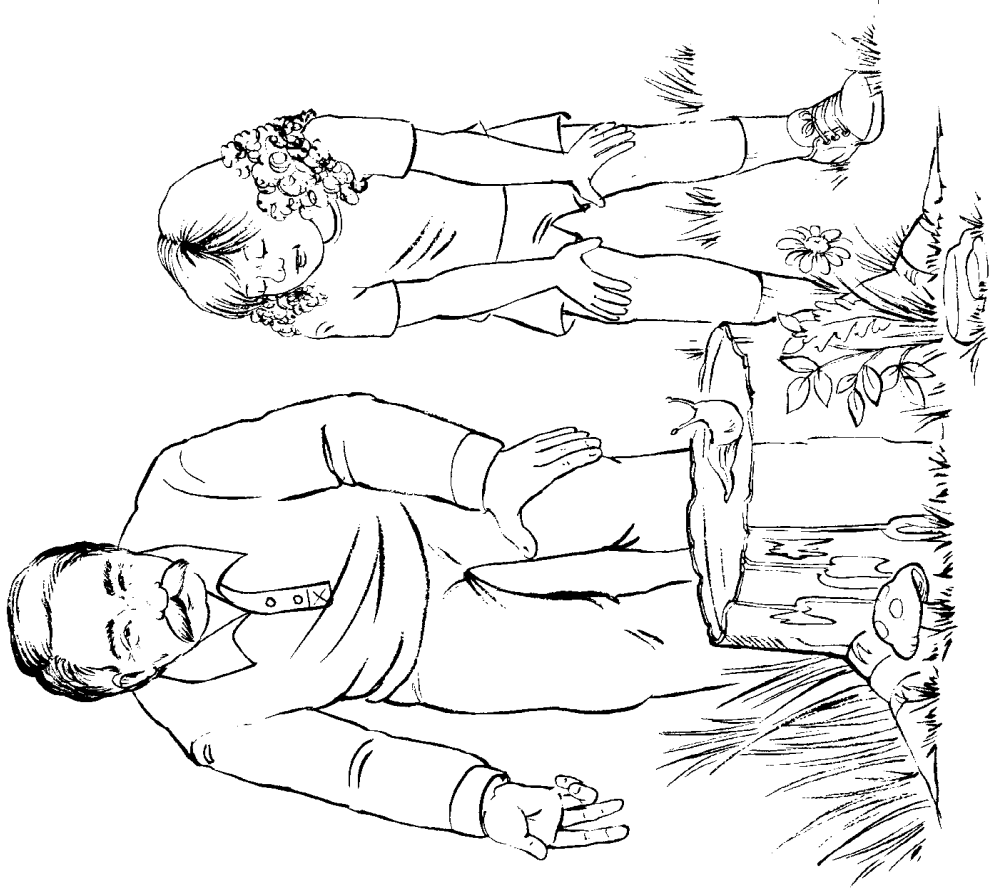

“Look on the stump,” said Gramps.

“It’s a slug.”

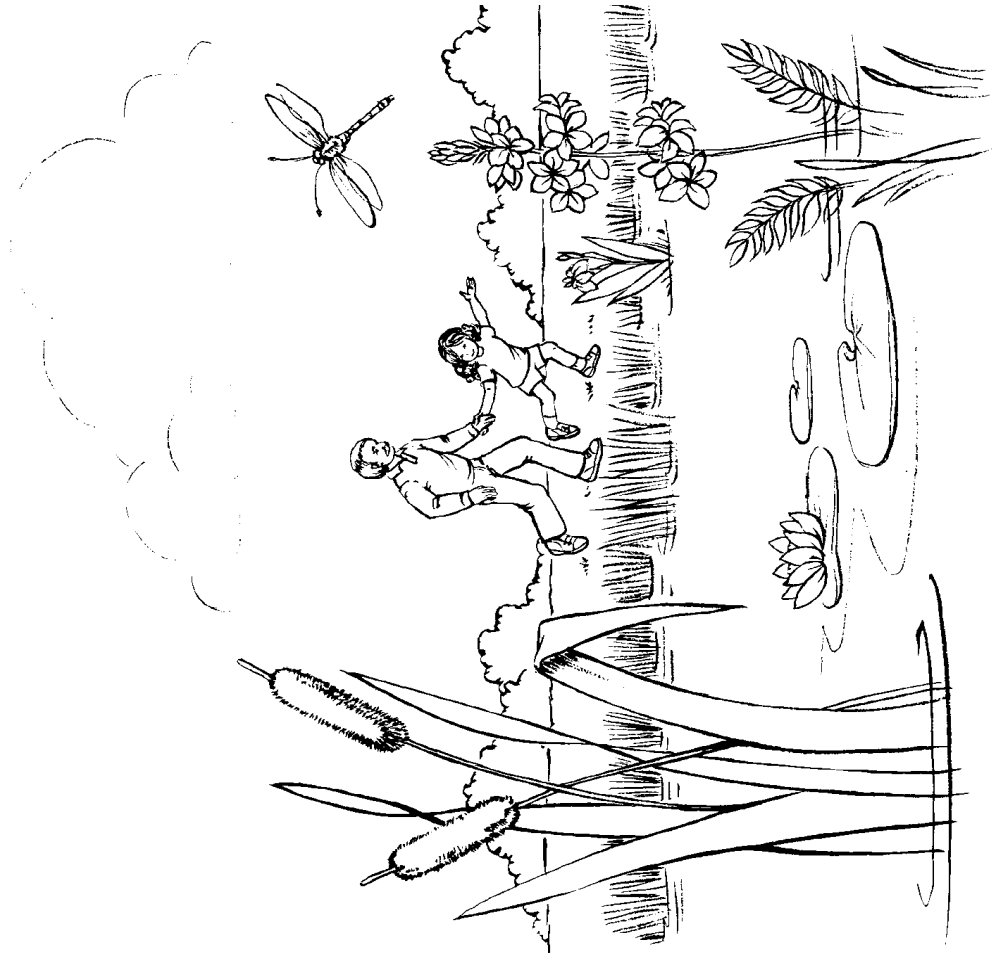

The sun was up at Plum Pond.

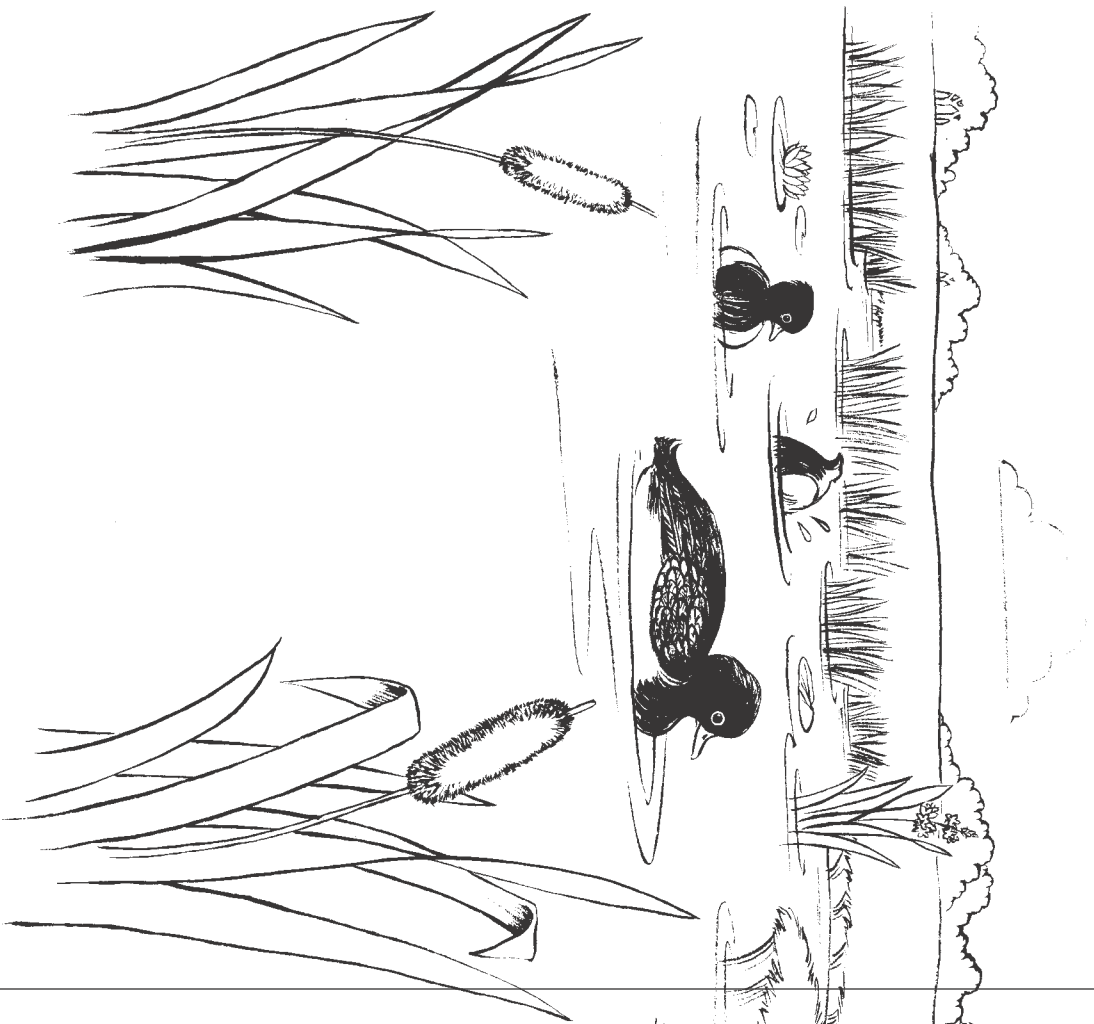

"I spot black ducks," said Jill.

4



"Plus I spot a gull," said Gramps.

5



Zack the bug can!

# Buzz and Zip

by Tamera Williams  
illustrated by Kersti Frigell

Core Decodable 3I



Bothell, WA • Chicago, IL • Columbus, OH • New York, NY





“What can buzz and zip?” asks Liz.

MHEonline.com



Copyright © 2015 McGraw-Hill Education

All rights reserved. The contents, or parts thereof, may be reproduced in print form for non-profit educational use with *SRA Open Court Reading*, provided such reproductions bear copyright notice, but may not be reproduced in any form for any other purpose without the prior written consent of McGraw-Hill Education, including, but not limited to, network storage or transmission, or broadcast for distance learning.

Send all inquiries to:  
McGraw-Hill Education  
8787 Orion Place  
Columbus, OH 43240



“Can I buzz? Can I zip?” Zack asks.



Zack is in a hat of fuzz.

Zack is in lots of fuzz.



Zack is in back of Liz.

4



Zack asks lots of stuff.

5



“Is he still a bug?” asks Liz.

“I am Zack,” he grins.

# Hills of Fuzz

by Tamera Williams  
illustrated by Kersti Frigell

Core Decodable 32



Bothell, WA • Chicago, IL • Columbus, OH • New York, NY



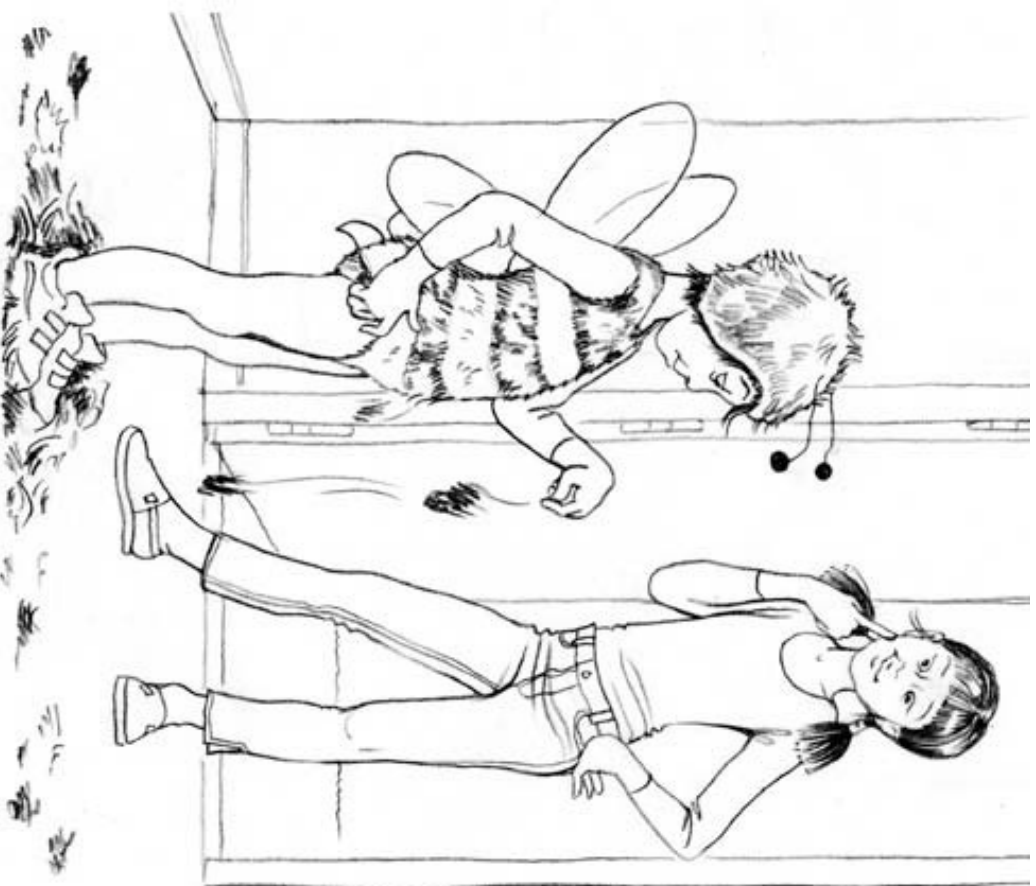

Zack stops.  
He stands in hills of fuzz.

MHEonline.com



Copyright © 2015 McGraw-Hill Education

All rights reserved. The contents, or parts thereof, may be reproduced in print form for non-profit educational use with *SRA Open Court Reading*, provided such reproductions bear copyright notice, but may not be reproduced in any form for any other purpose without the prior written consent of McGraw-Hill Education, including, but not limited to, network storage or transmission, or broadcast for distance learning.

Send all inquiries to:  
McGraw-Hill Education  
8787 Orion Place  
Columbus, OH 43240





As he hums, lots of fuzz drops.



Zack zigzags past Liz.

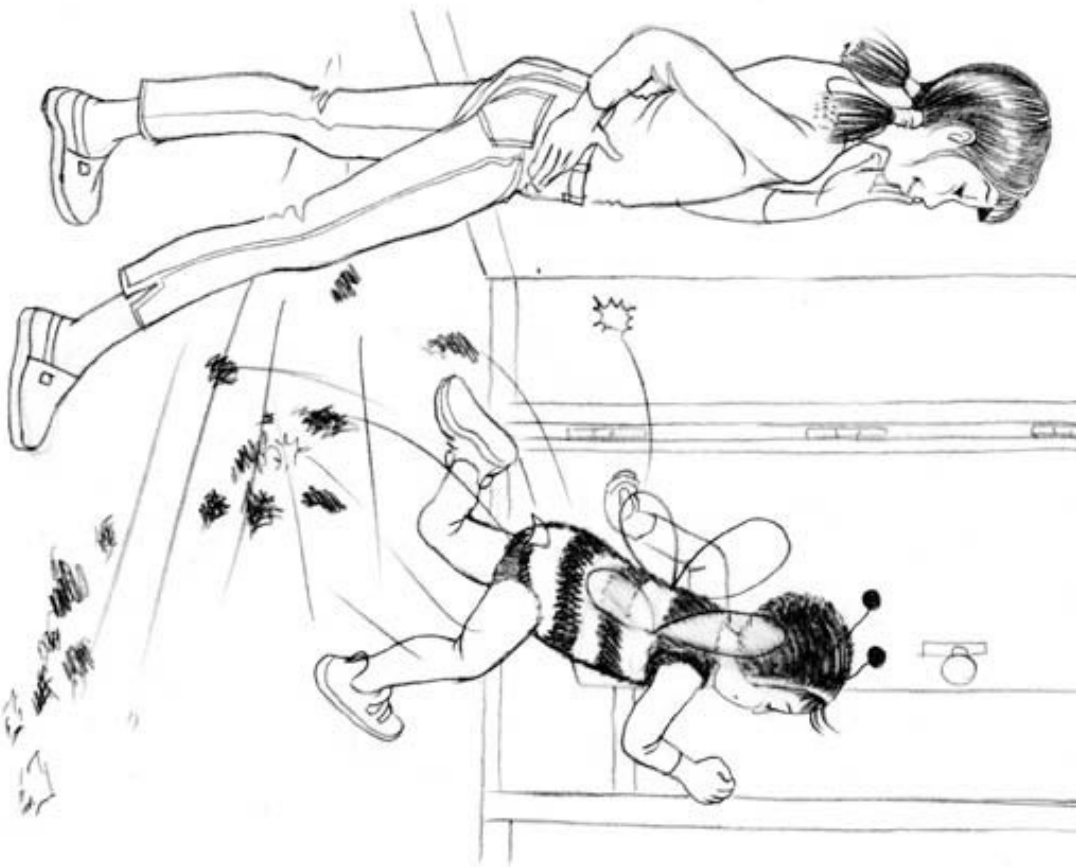

As he zags, bits of fuzz drop.

4



Zack hums as he zigs and zags.

5



Dad has his plugs.

# Rock and Jazz

by Bud Hamilton  
illustrated by Lynne Avril

Core Decodable 33



Bothell, WA • Chicago, IL • Columbus, OH • New York, NY

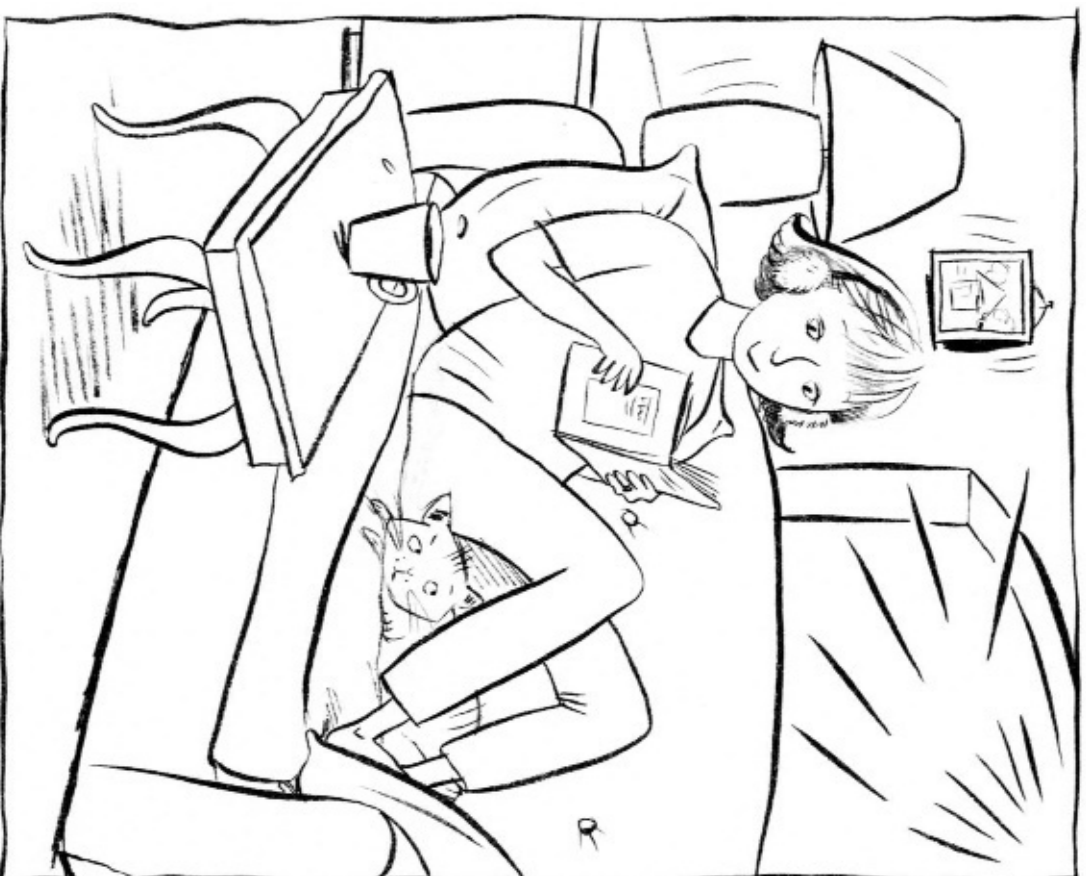

Mom has on muffs.

MHEonline.com



Copyright © 2015 McGraw-Hill Education

All rights reserved. The contents, or parts thereof, may be reproduced in print form for non-profit educational use with *SRA Open Court Reading*, provided such reproductions bear copyright notice, but may not be reproduced in any form for any other purpose without the prior written consent of McGraw-Hill Education, including, but not limited to, network storage or transmission, or broadcast for distance learning.

Send all inquiries to:  
McGraw-Hill Education  
8787 Orion Place  
Columbus, OH 43240





Mom has a gift of plugs.

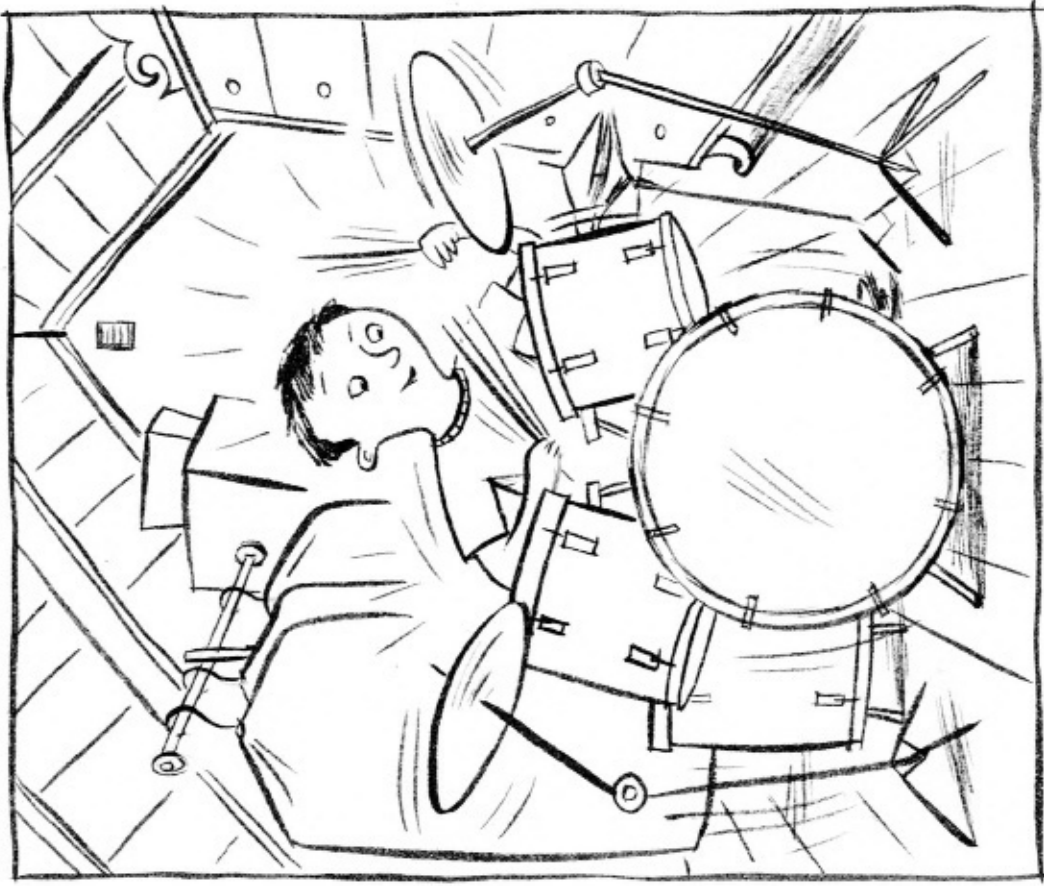

In the attic, Jim has drums.

Jim hits his drums.



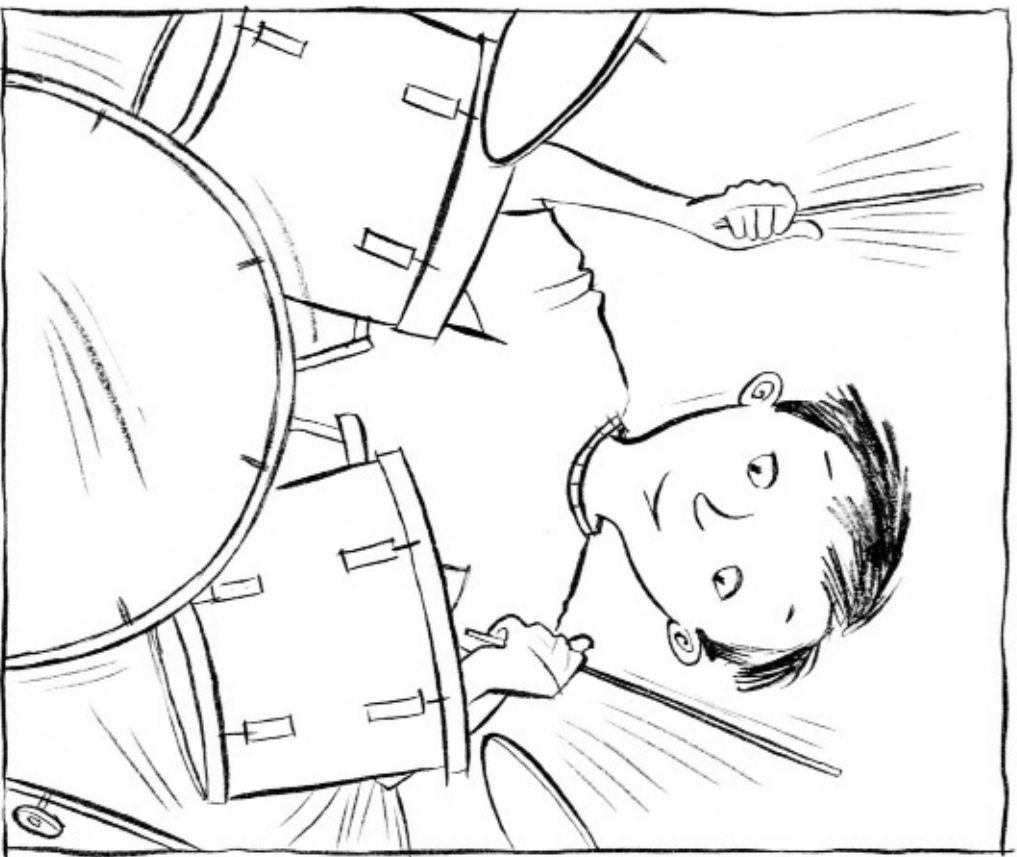

Jim's drumsticks hit and hit.

Bam! Bam! Bam!

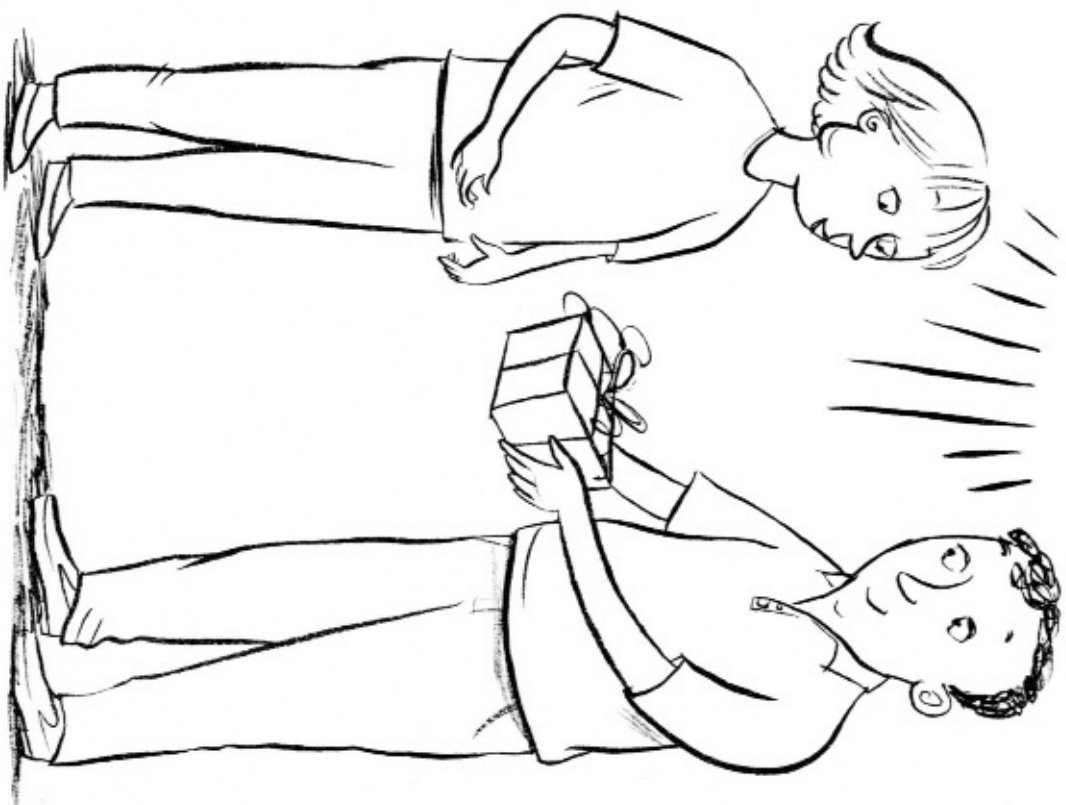

Dad has a gift of muffins.



Madge did not budge.

Madge just hits drums.

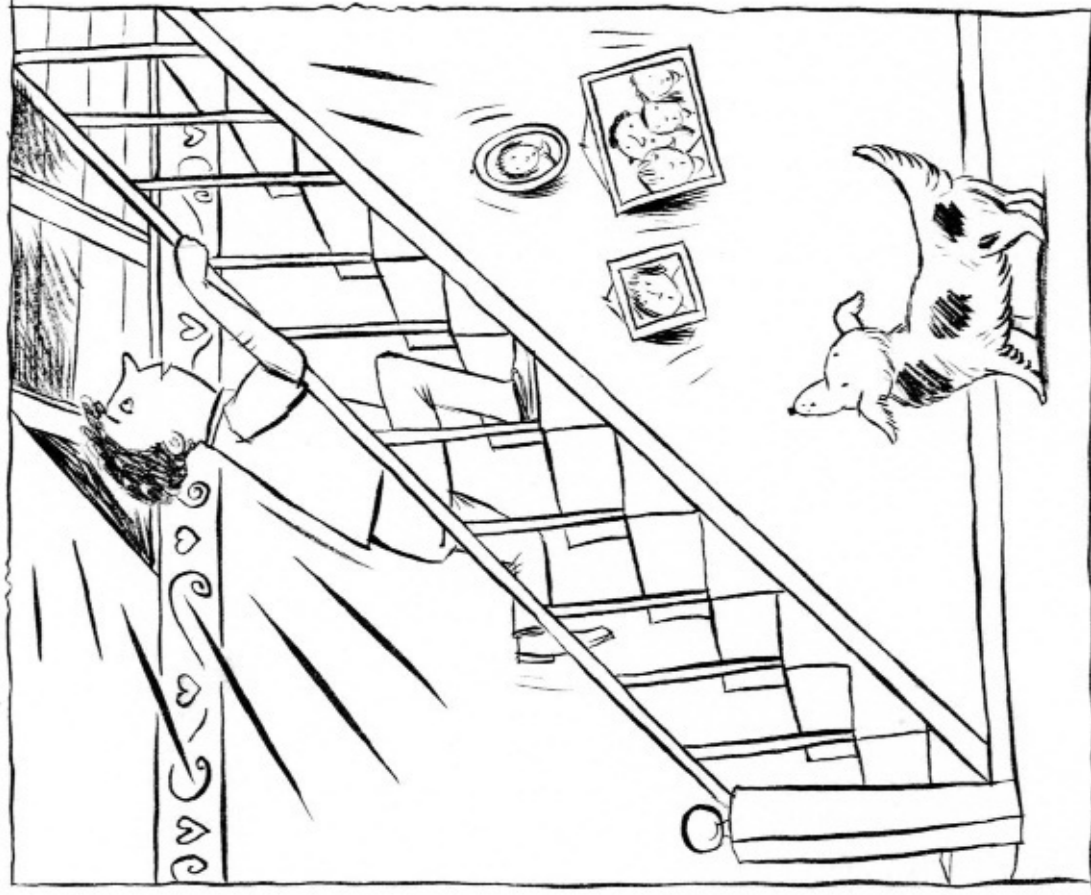

Dad zips to the attic.

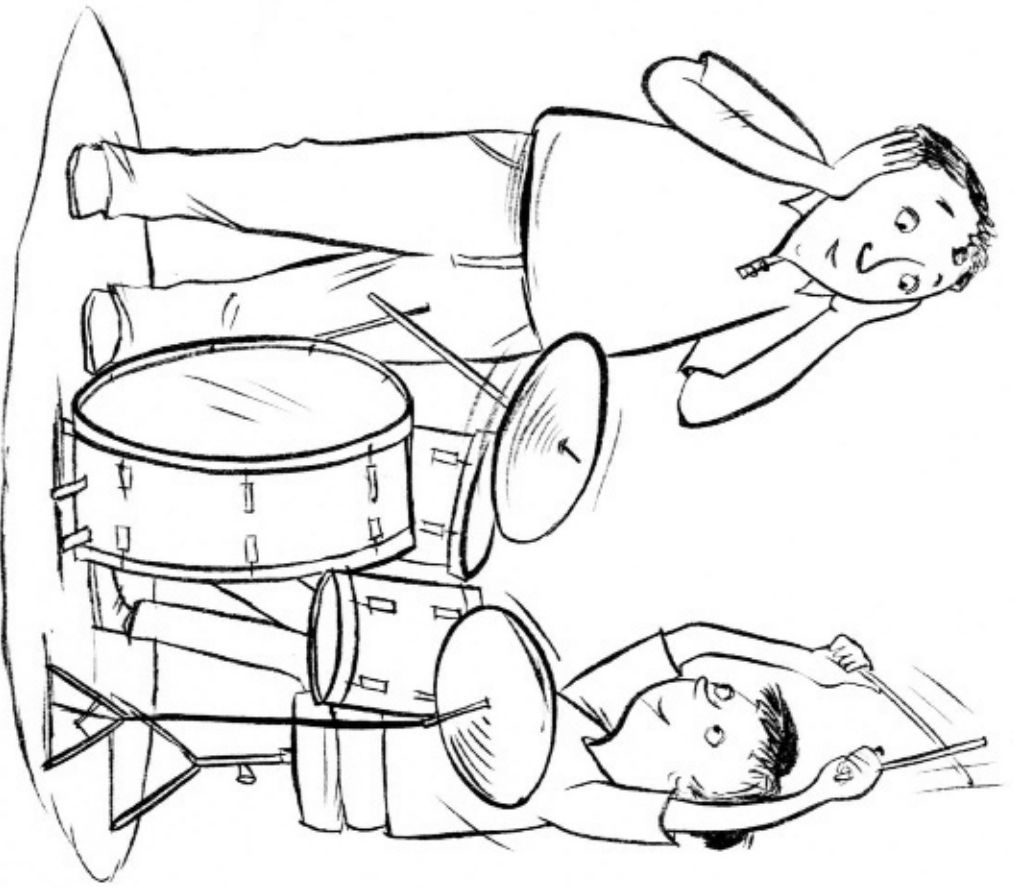

"I am in a rock band," said Jim.

6



Jim did not budge.

He just hits drums.

11



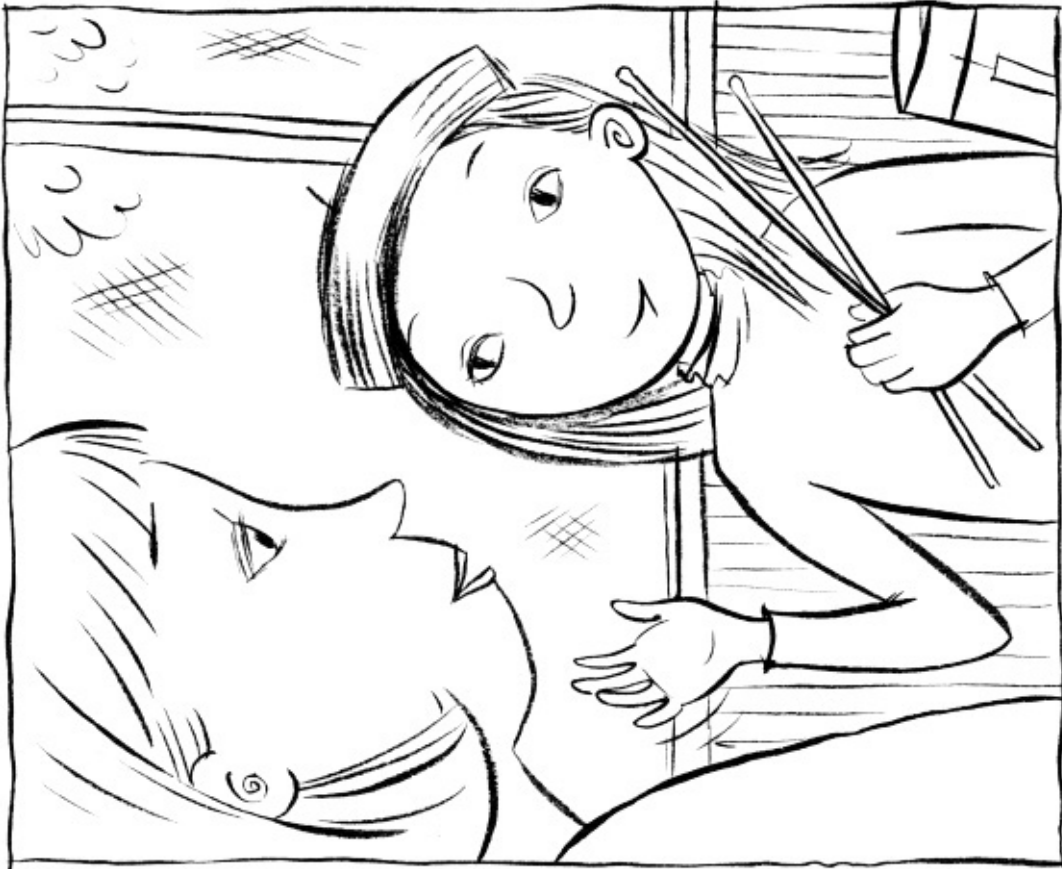

“I am in a jazz band,” said Madge.

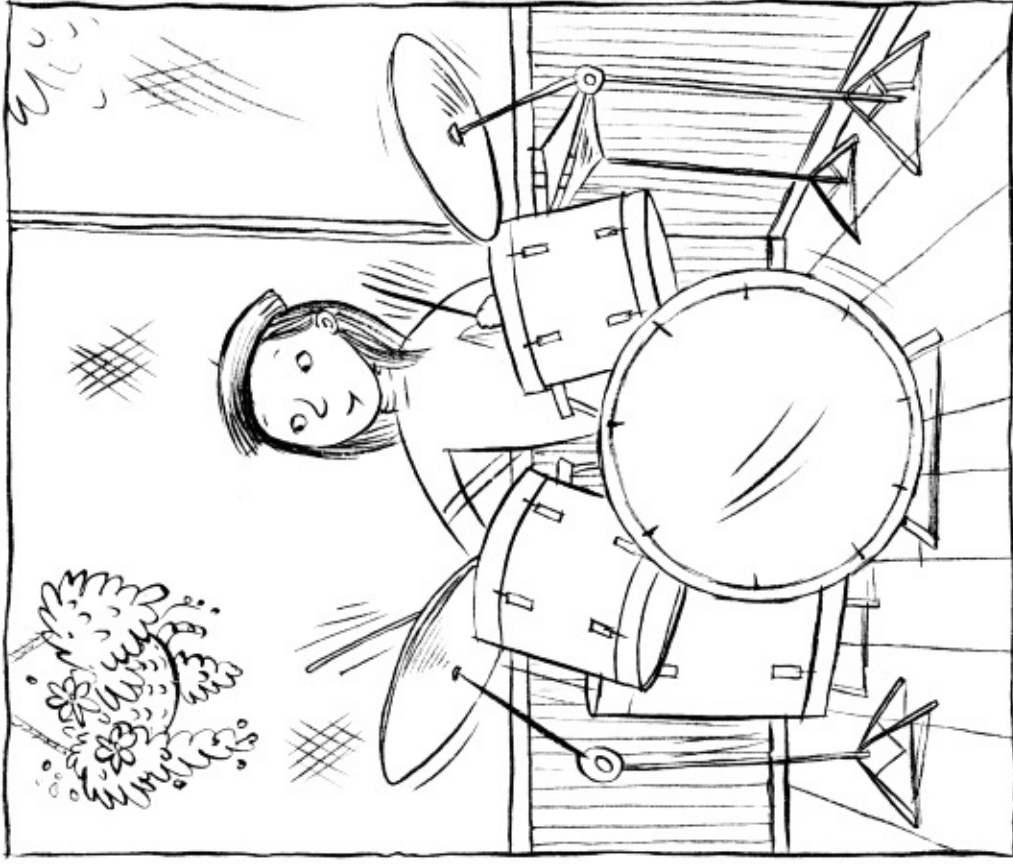

In back, Madge has drums.  
Madge hits the drums.



Bam! Bam! Bam!

Madge's drumsticks hit and hit.

8



Mom zips to the back.

9



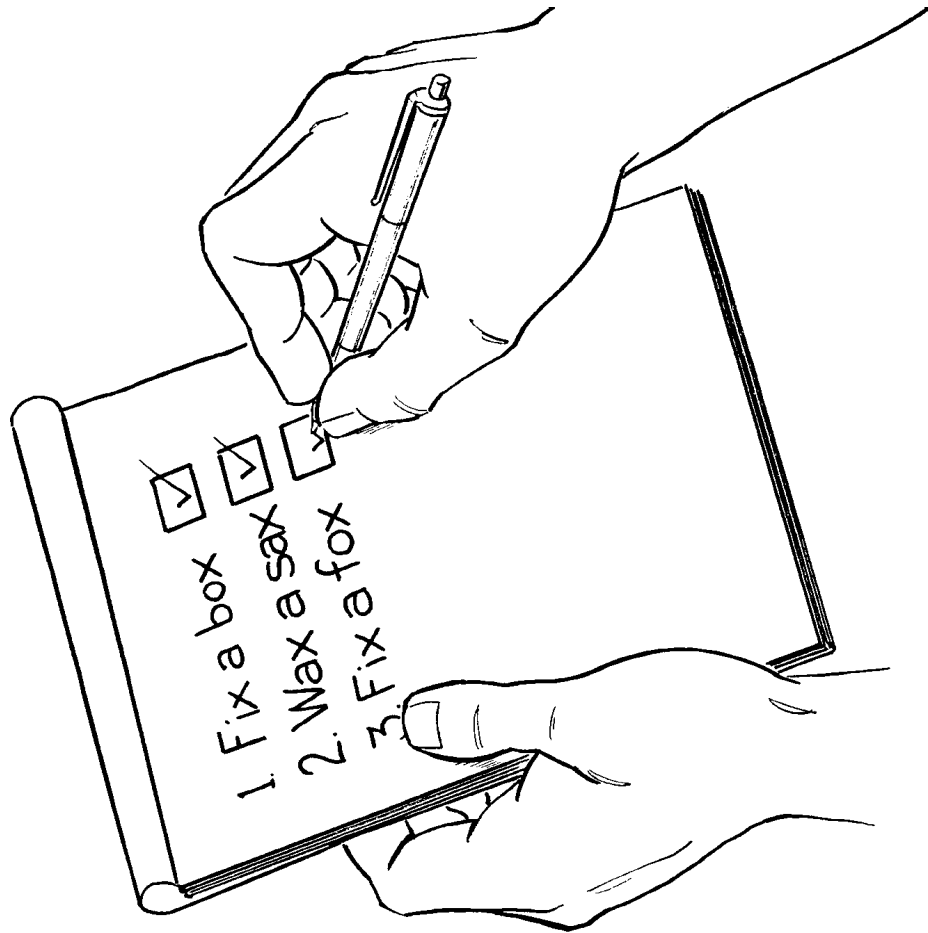

# Max and Sam

by Rebecca Blankenhorn  
illustrated by Barry Mullins

Core Decodable 34



Bothell, WA • Chicago, IL • Columbus, OH • New York, NY



Last, Max can list stuff.

MHEonline.com



Copyright © 2015 McGraw-Hill Education

All rights reserved. The contents, or parts thereof, may be reproduced in print form for non-profit educational use with *SRA Open Court Reading*, provided such reproductions bear copyright notice, but may not be reproduced in any form for any other purpose without the prior written consent of McGraw-Hill Education, including, but not limited to, network storage or transmission, or broadcast for distance learning.

Send all inquiries to:  
McGraw-Hill Education  
8787 Orion Place  
Columbus, OH 43240

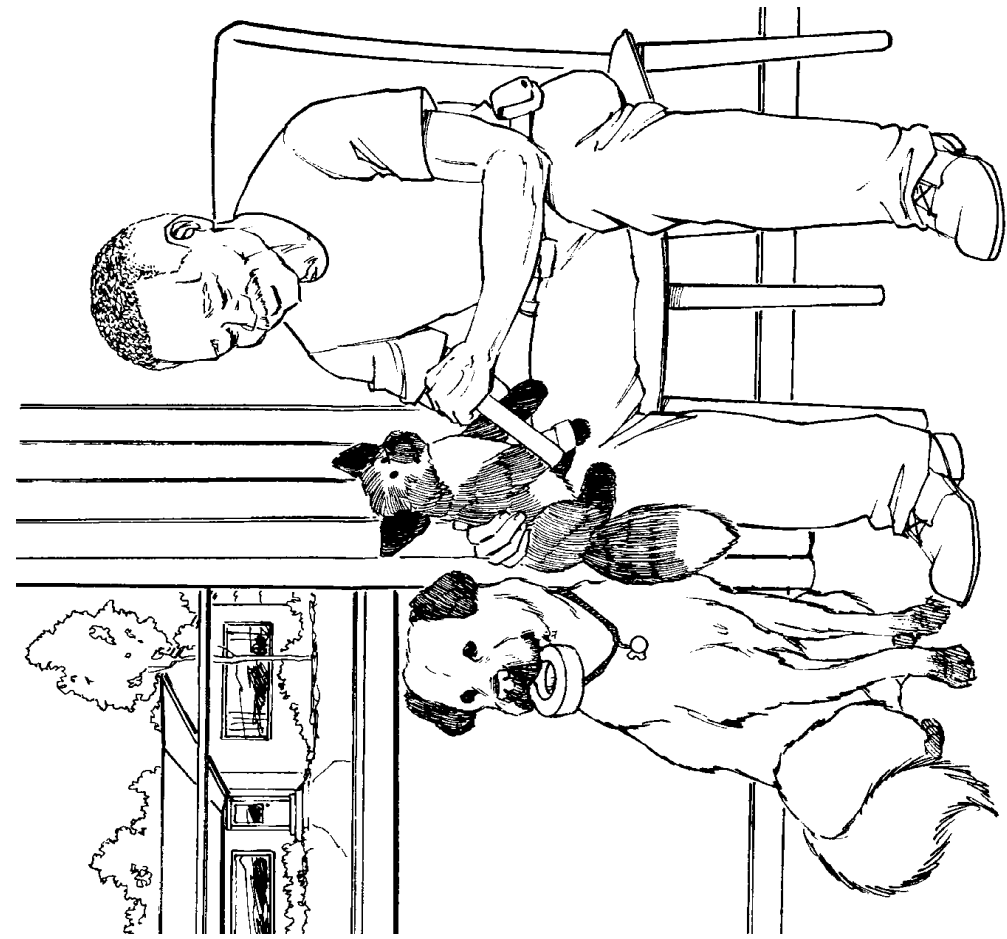

Max and Sam fix a fox.

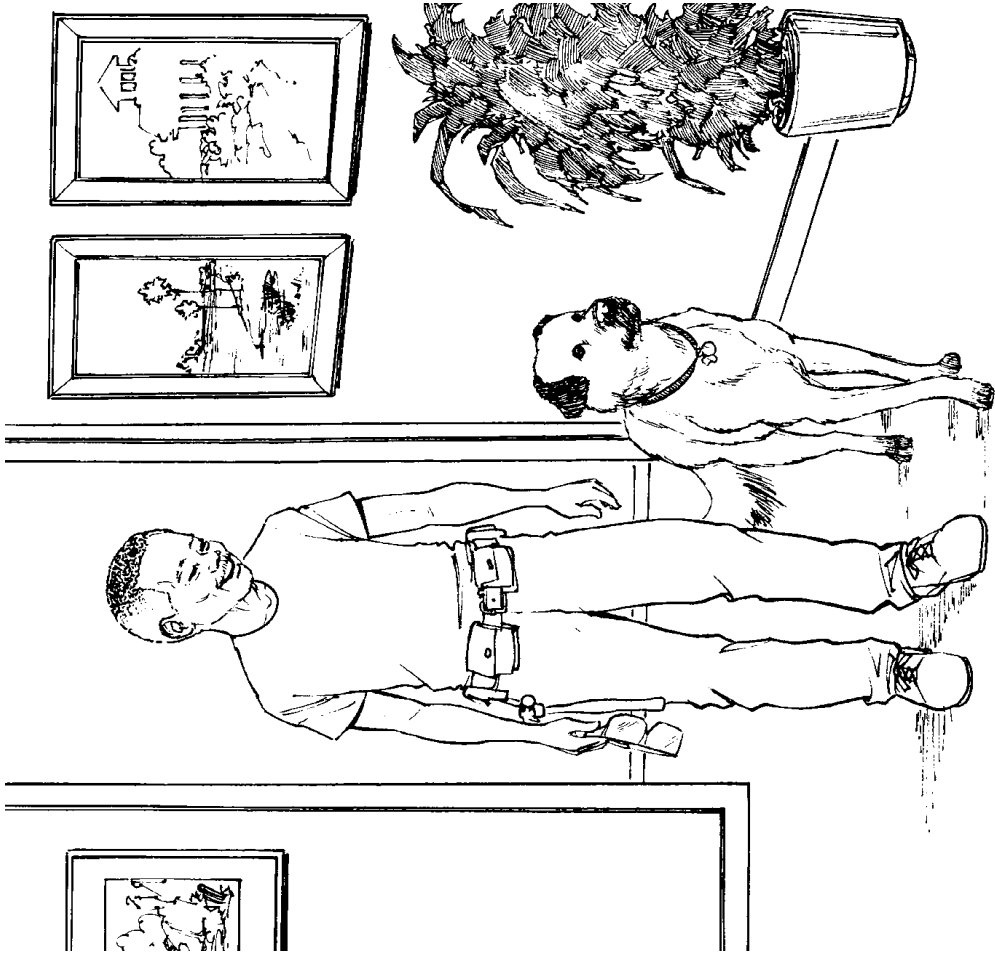

Max and Sam fix stuff.

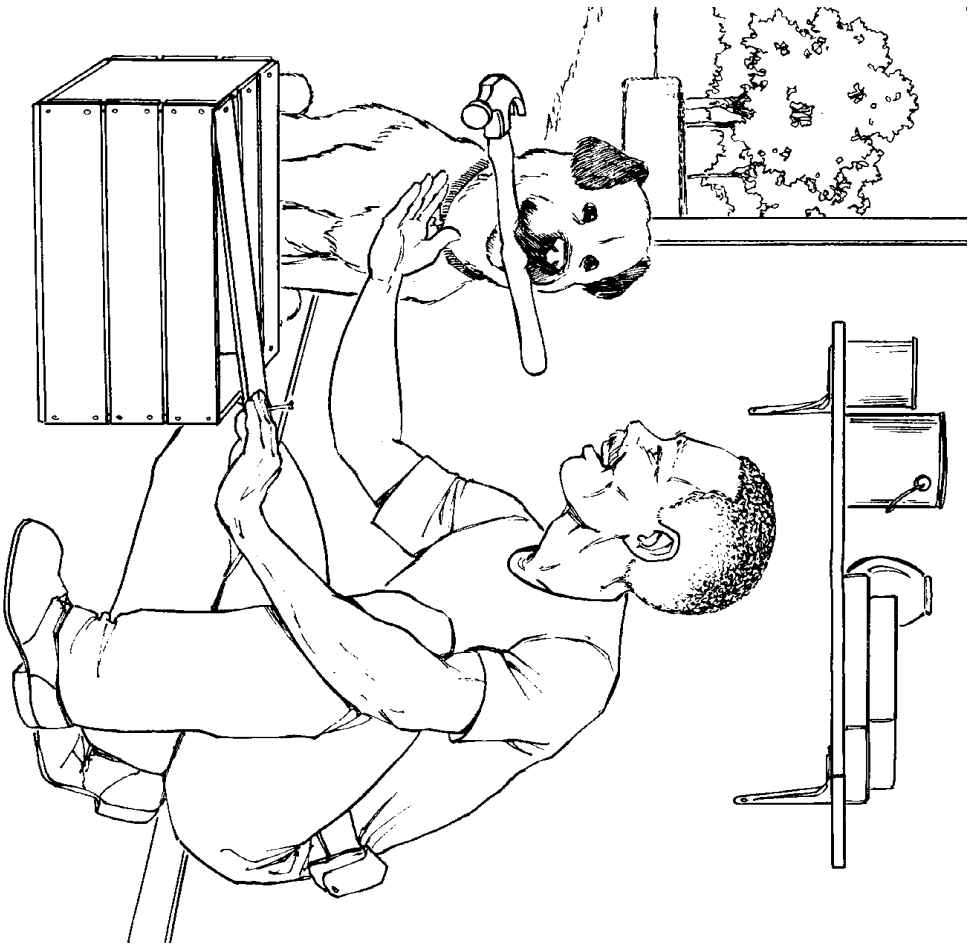

Max and Sam fix a box.

4

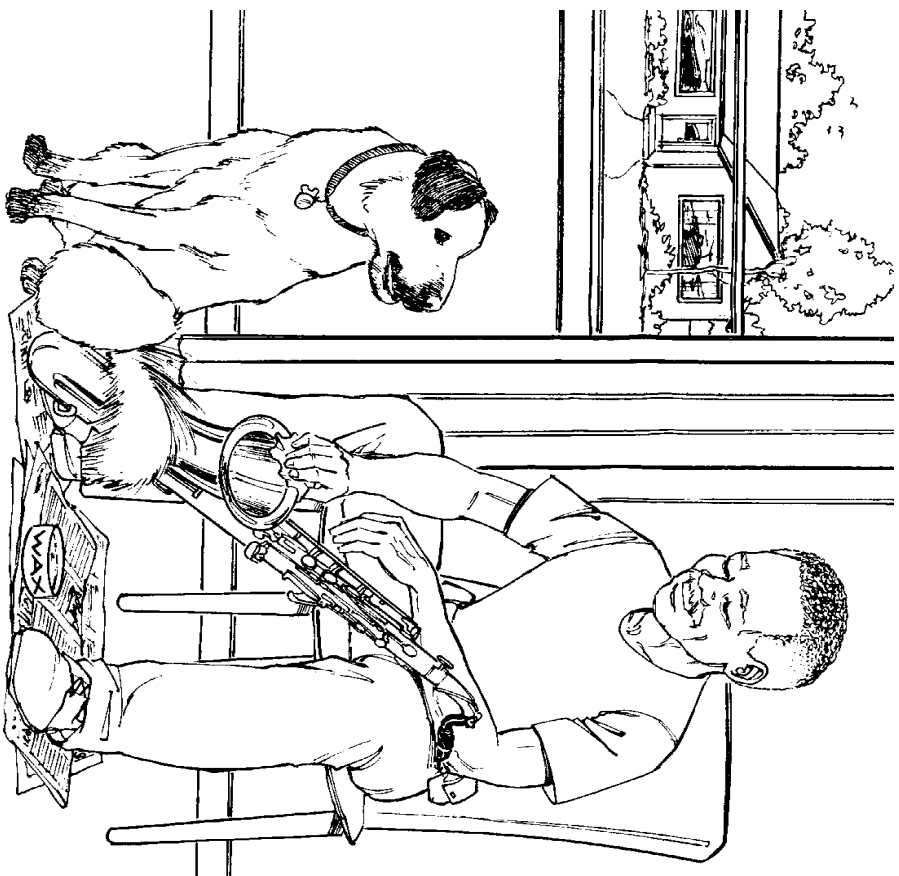

Max can rub a sax.

Can Sam rub a sax?

5



At sun-up, a red fox rests. It sits down.

# A Red Fox

by Joaquin Garcia  
illustrated by Pat Lucas-Morris

Core Decodable 35



Bothell, WA • Chicago, IL • Columbus, OH • New York, NY



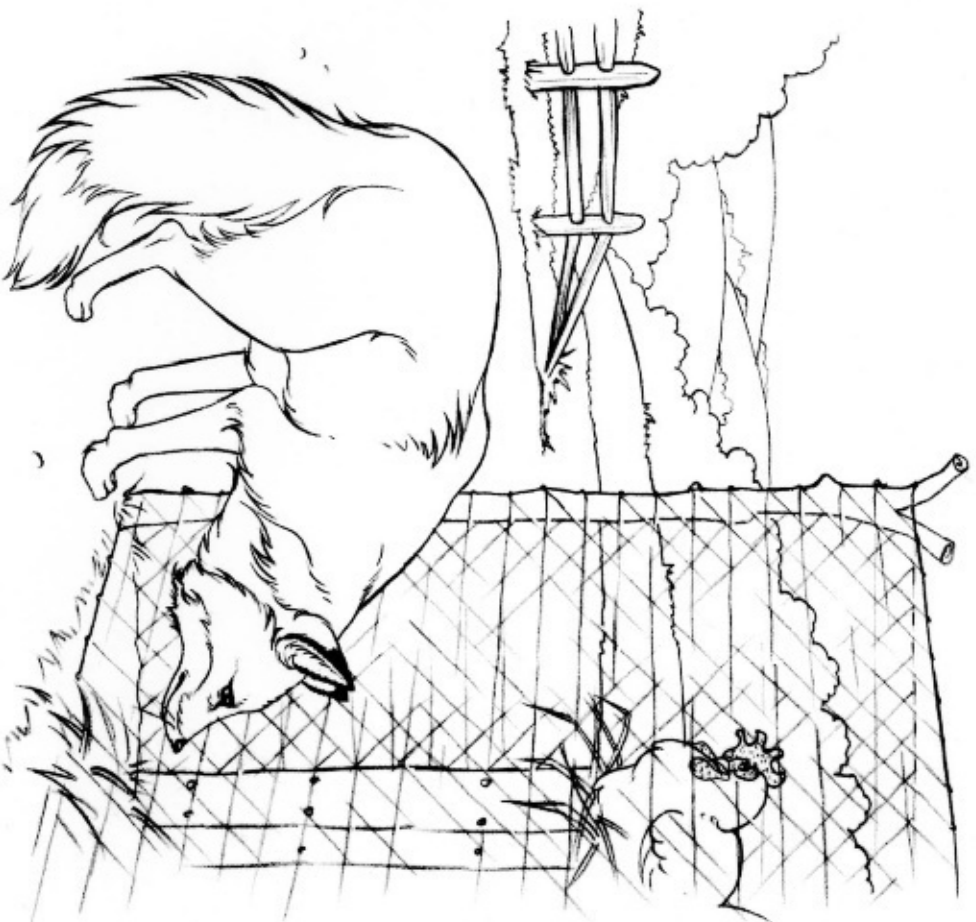

A red fox can smell hens.

MHEonline.com



Copyright © 2015 McGraw-Hill Education

All rights reserved. The contents, or parts thereof, may be reproduced in print form for non-profit educational use with SRA Open Court Reading, provided such reproductions bear copyright notice, but may not be reproduced in any form for any other purpose without the prior written consent of McGraw-Hill Education, including, but not limited to, network storage or transmission, or broadcast for distance learning.

Send all inquiries to:  
McGraw-Hill Education  
8787 Orion Place  
Columbus, OH 43240



A red fox can hunt down a rabbit.



A red fox has a den.



Its den is down in grass.

4

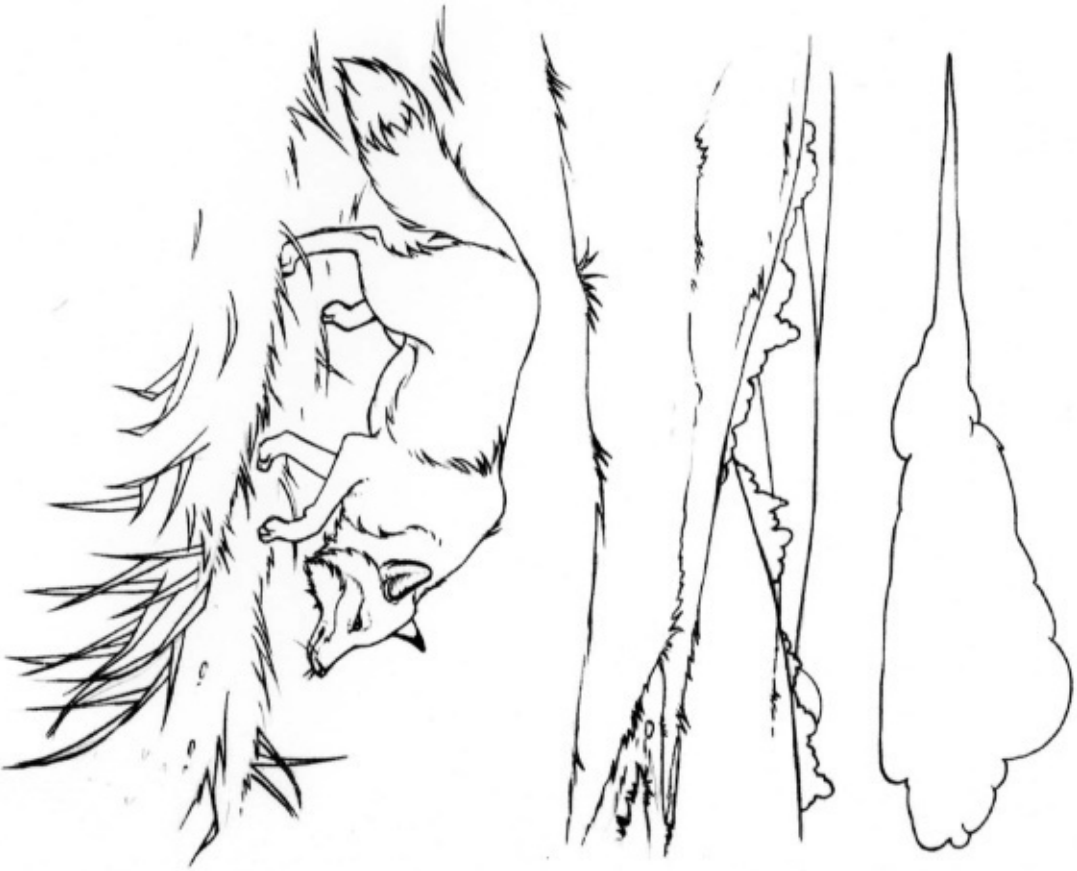

If the sun is down, a red fox hunts.

5



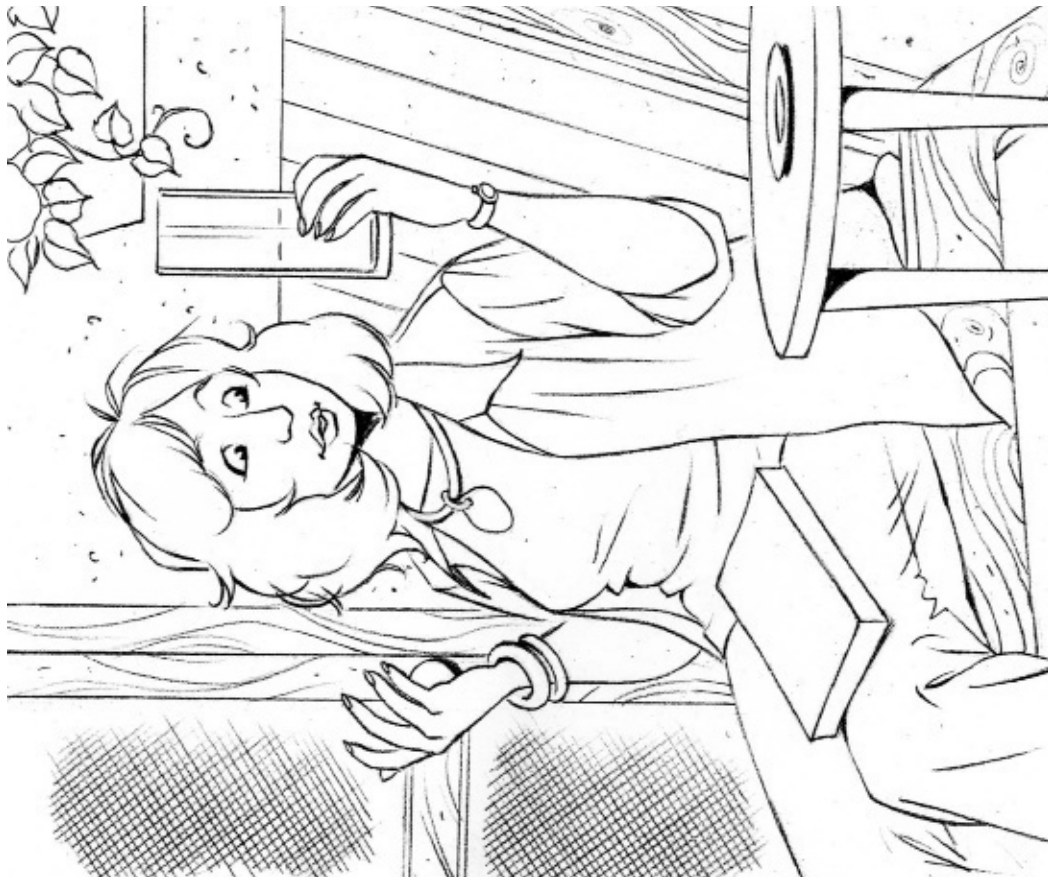

Mom sat up and lifted the glass.

“I cannot sip!” said Mom.

# The Glass

by Antonio Colantoni  
illustrated by Mark Corcoran

Core Decodable 36



Bothell, WA • Chicago, IL • Columbus, OH • New York, NY



Bugs buzzed back to the nest.

MHEonline.com



Copyright © 2015 McGraw-Hill Education

All rights reserved. The contents, or parts thereof, may be reproduced in print form for non-profit educational use with SRA Open Court Reading, provided such reproductions bear copyright notice, but may not be reproduced in any form for any other purpose without the prior written consent of McGraw-Hill Education, including, but not limited to, network storage or transmission, or broadcast for distance learning.

Send all inquiries to:  
McGraw-Hill Education  
8787 Orion Place  
Columbus, OH 43240





Bugs buzzed in a glass.



Mom filled a glass.

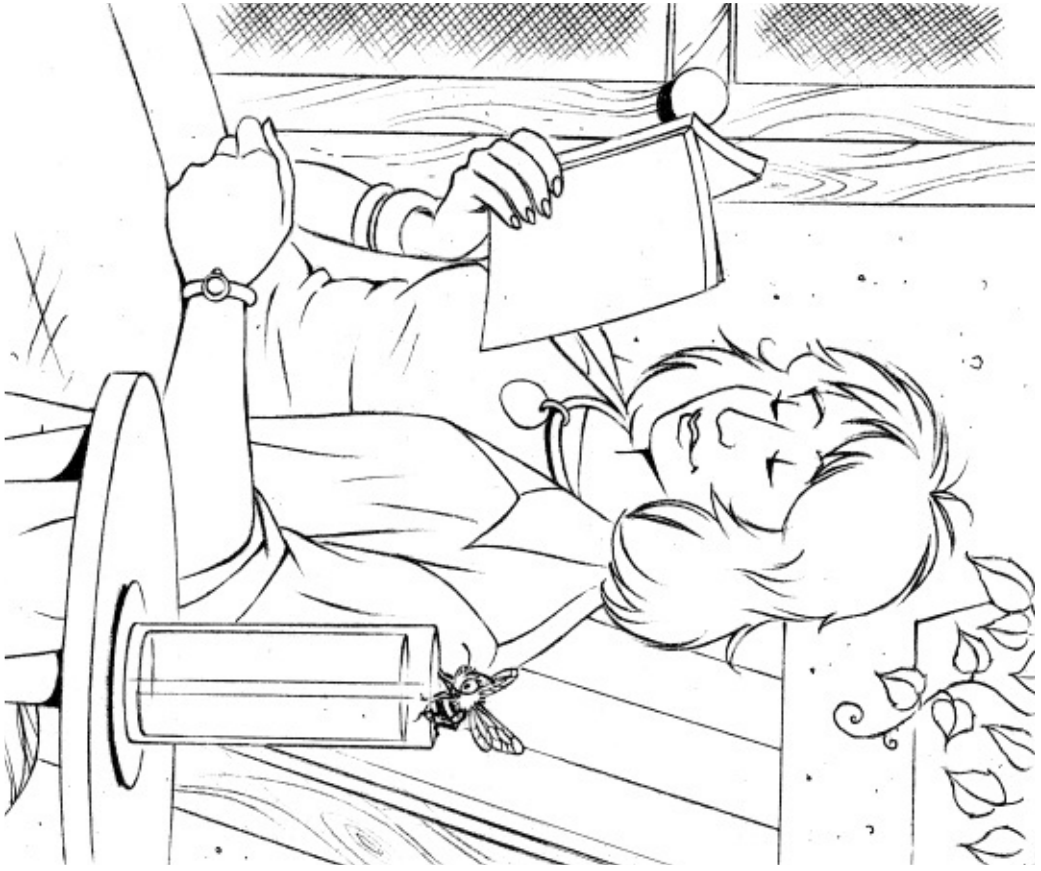

As Mom rested, a bug smelled the glass.

What was in it?

4



The bug buzzed to its nest.

5

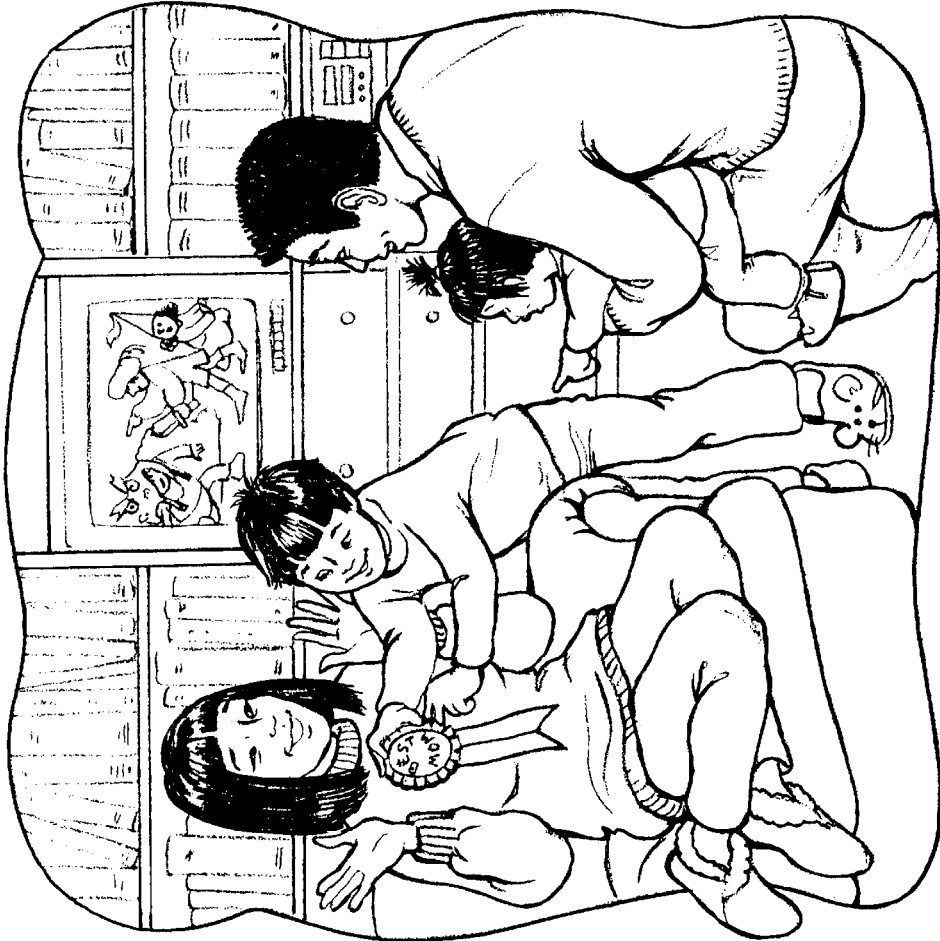

Dad handed Tom a pin.  
Tom pinned it on Mom.  
The pin said BEST MOM.

# Best Mom

by Lisa Boggs  
illustrated by Kersti Frigell

Core Decodable 37



Bothell, WA • Chicago, IL • Columbus, OH • New York, NY

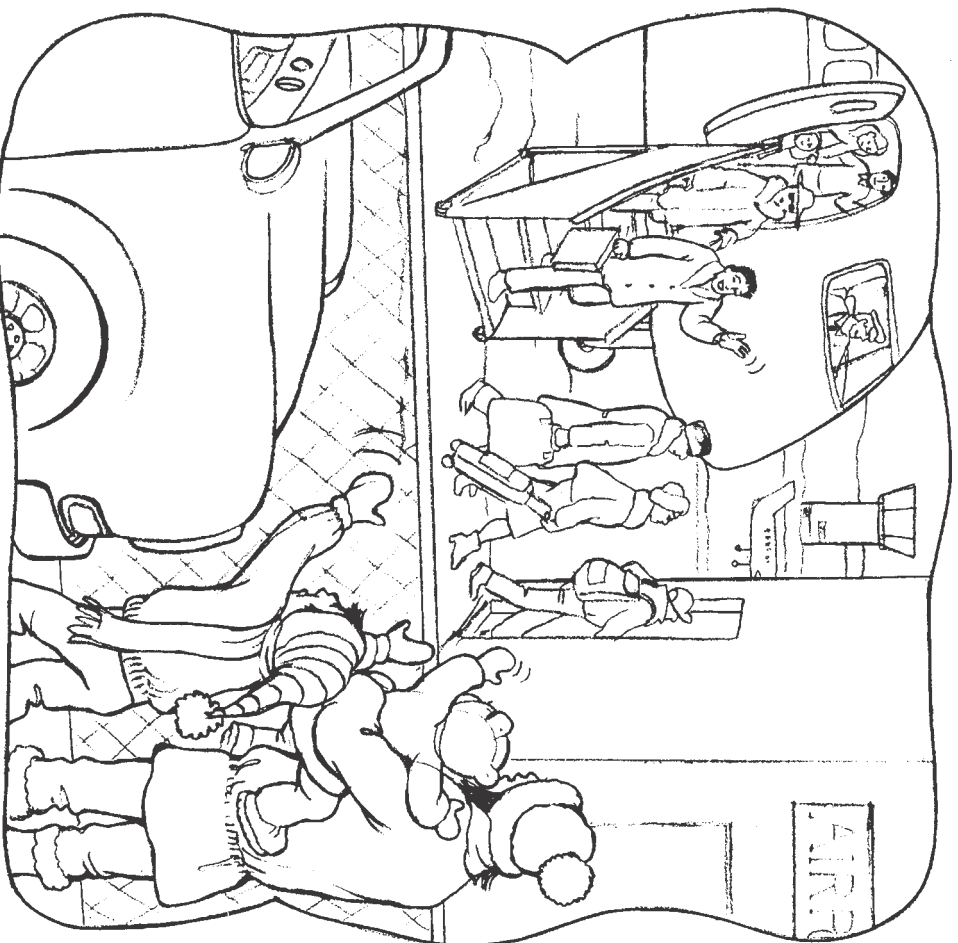

Dad landed.

Mom picked him up.

MHEonline.com



Copyright © 2015 McGraw-Hill Education

All rights reserved. The contents, or parts thereof, may be reproduced in print form for non-profit educational use with SRA Open Court Reading, provided such reproductions bear copyright notice, but may not be reproduced in any form for any other purpose without the prior written consent of McGraw-Hill Education, including, but not limited to, network storage or transmission, or broadcast for distance learning.

Send all inquiries to:  
McGraw-Hill Education  
8787 Orion Place  
Columbus, OH 43240



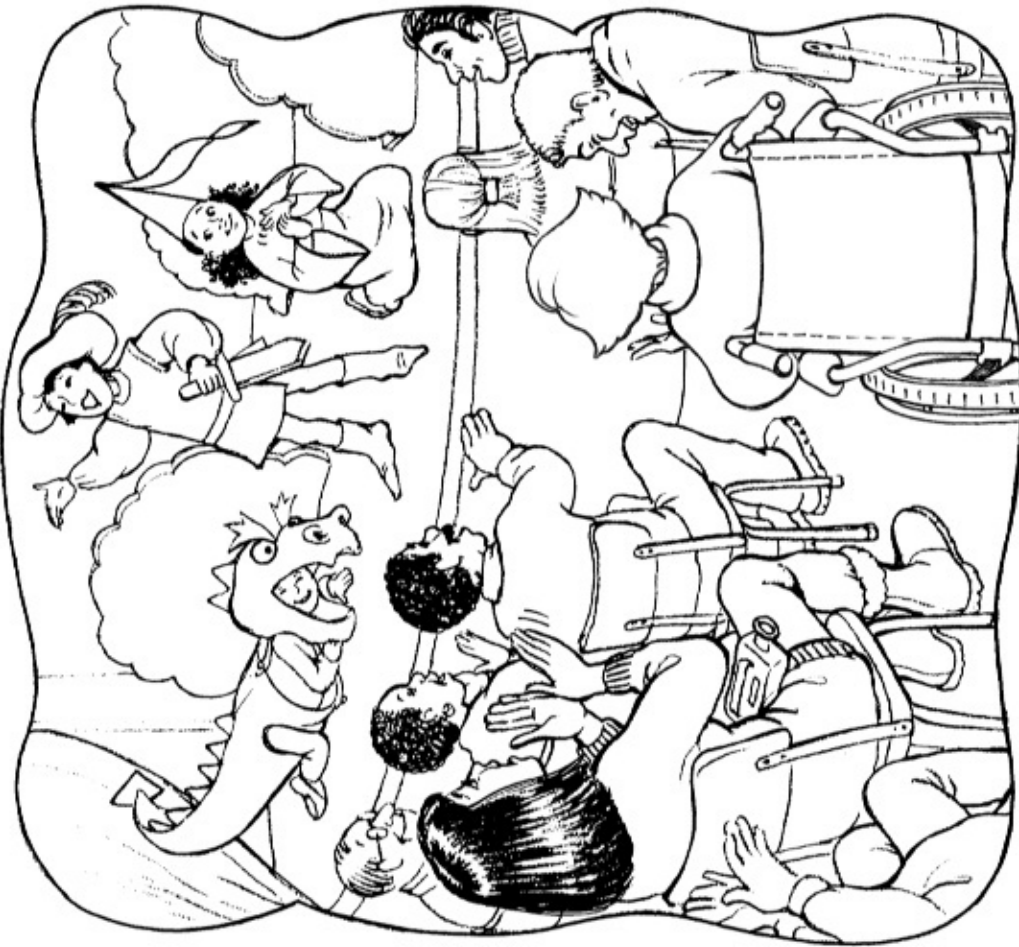

Tom acted.  
Mom clapped.

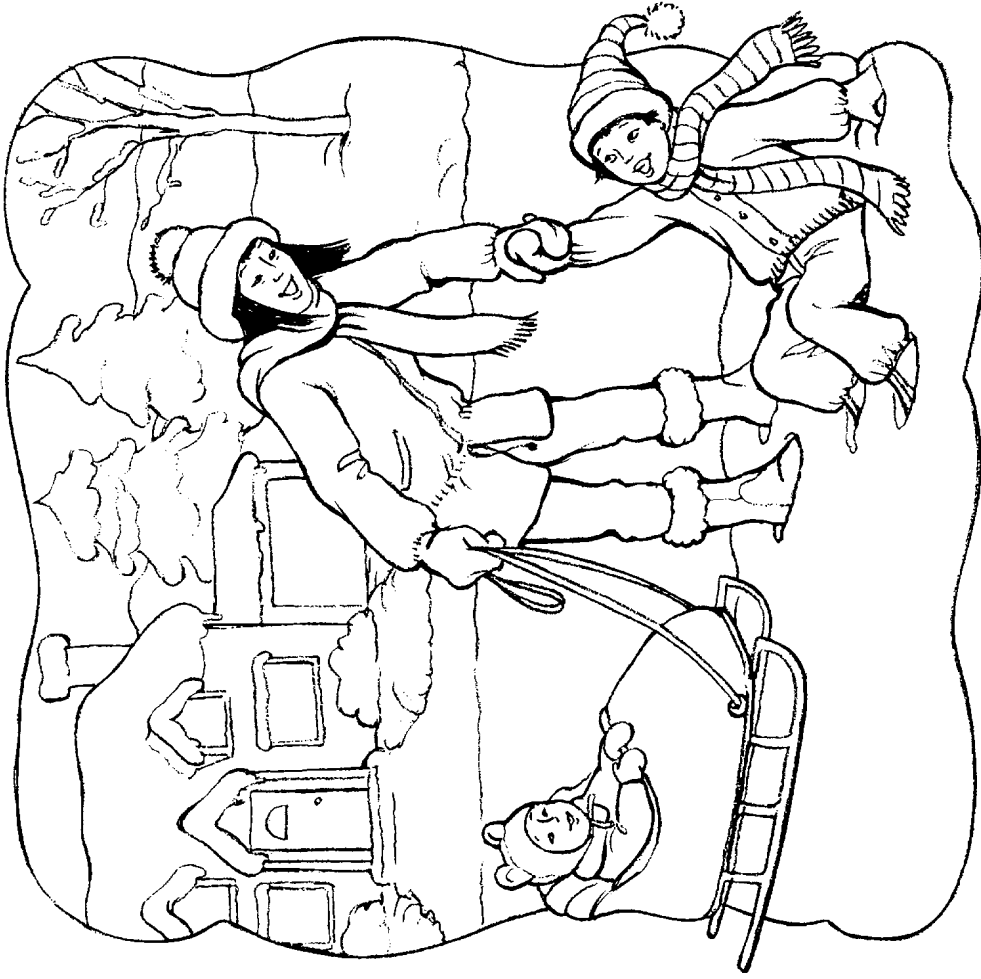

Tom slipped.  
Mom helped him up.



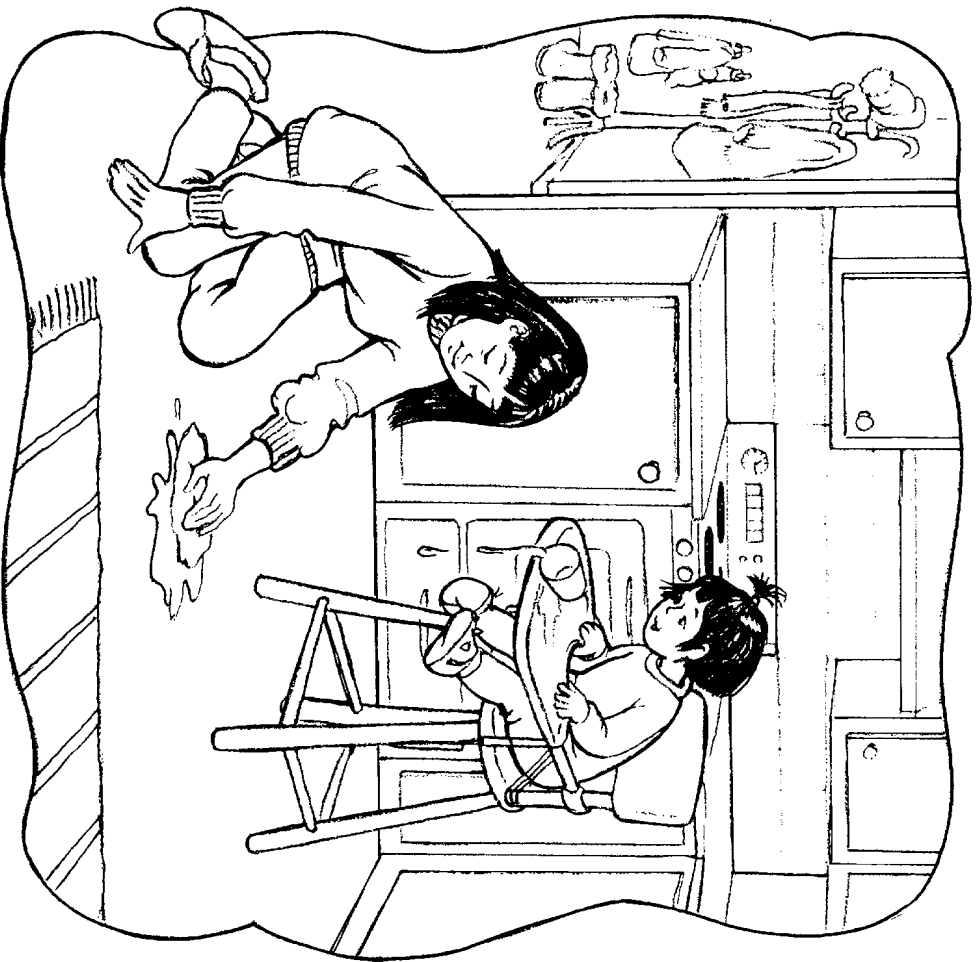

Pam spilled it.

Mom mopped it.

4

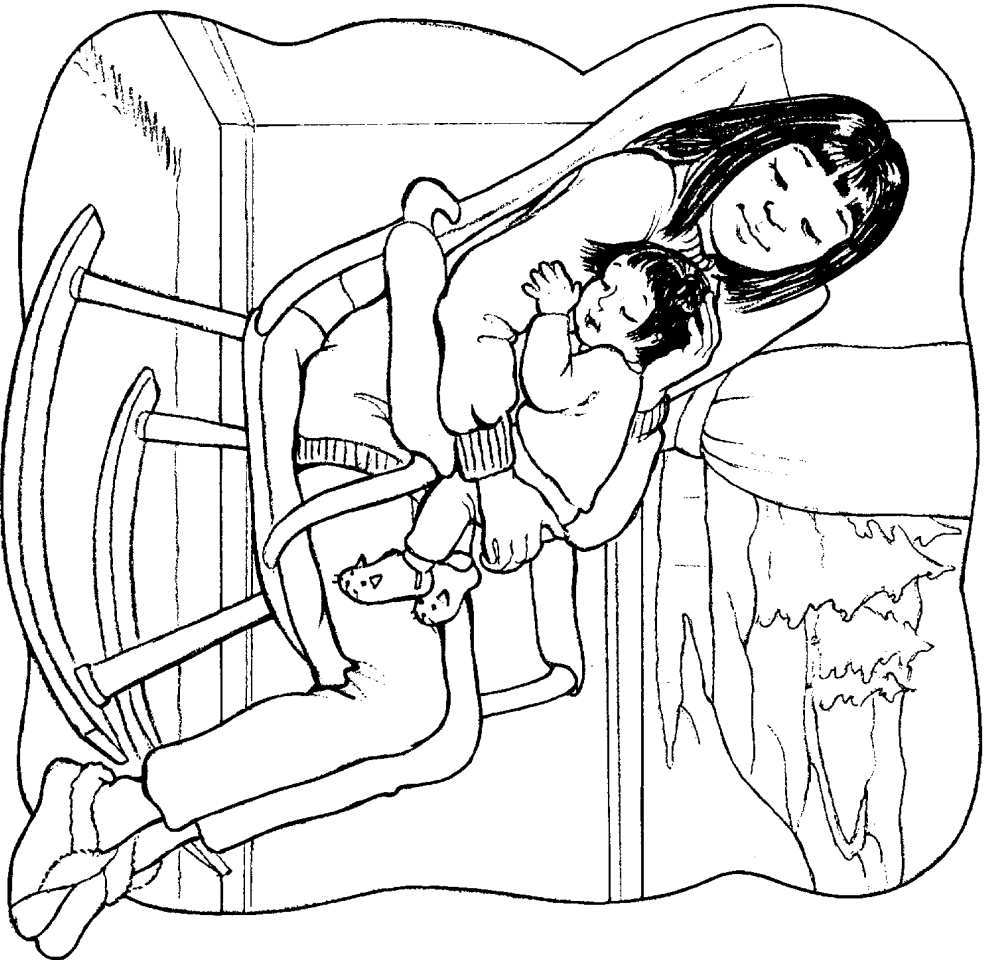

Mom patted Pam.

Pam napped.

5

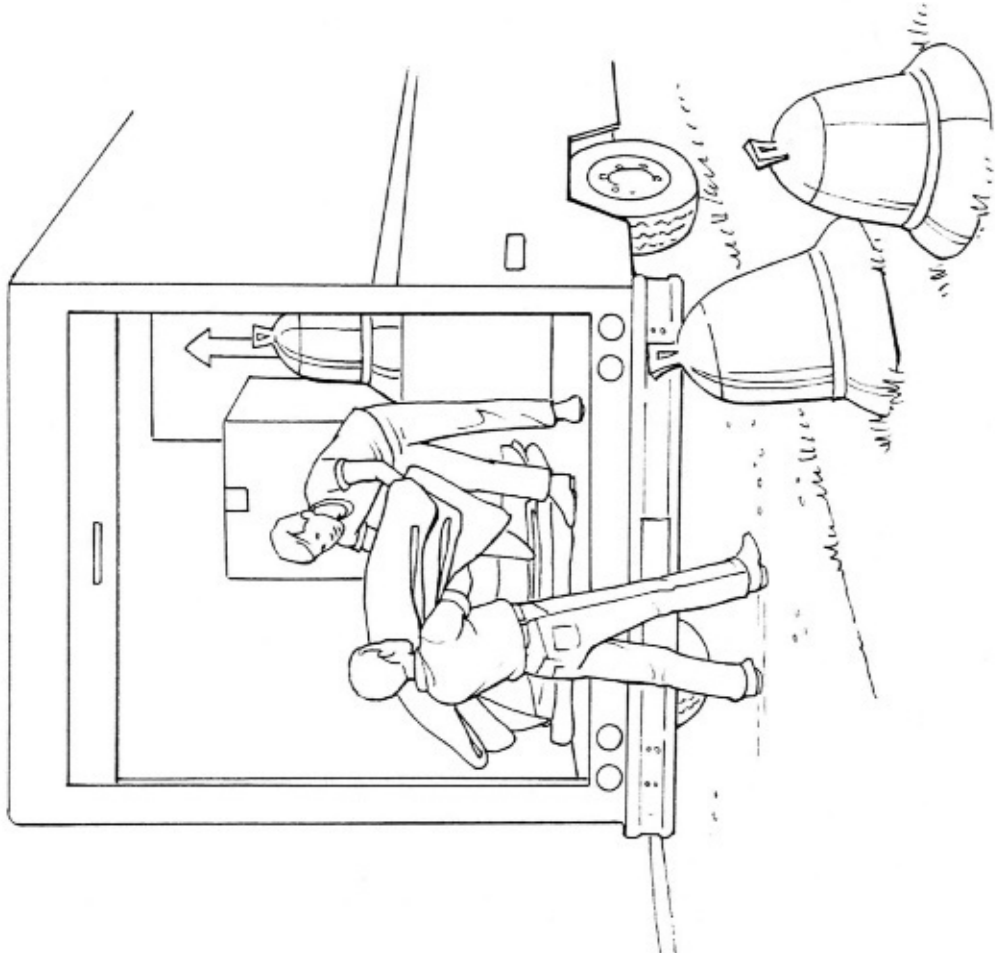

The men set stuff back in the truck.

# Fix a Truck

by Jessica Evans  
illustrated by Meryl Henderson

Core Decodable 38



Bothell, WA • Chicago, IL • Columbus, OH • New York, NY

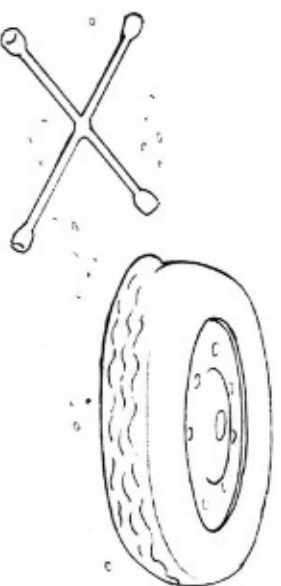
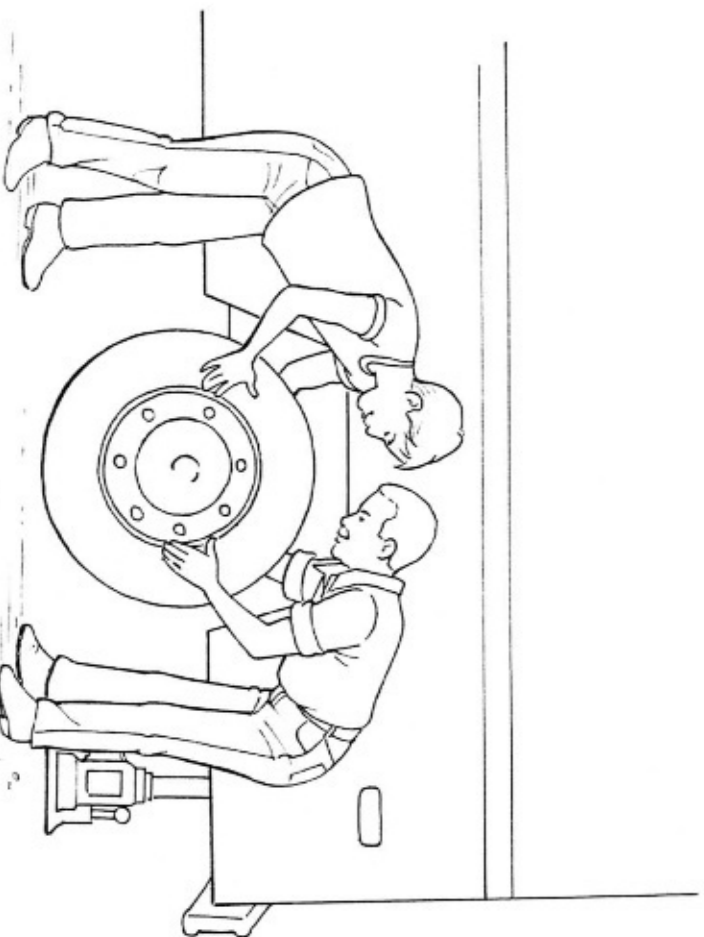

The men fixed the truck.

MHEonline.com



Copyright © 2015 McGraw-Hill Education

All rights reserved. The contents, or parts thereof, may be reproduced in print form for non-profit educational use with *SRA Open Court Reading*, provided such reproductions bear copyright notice, but may not be reproduced in any form for any other purpose without the prior written consent of McGraw-Hill Education, including, but not limited to, network storage or transmission, or broadcast for distance learning.

Send all inquiries to:  
McGraw-Hill Education  
8787 Orion Place  
Columbus, OH 43240

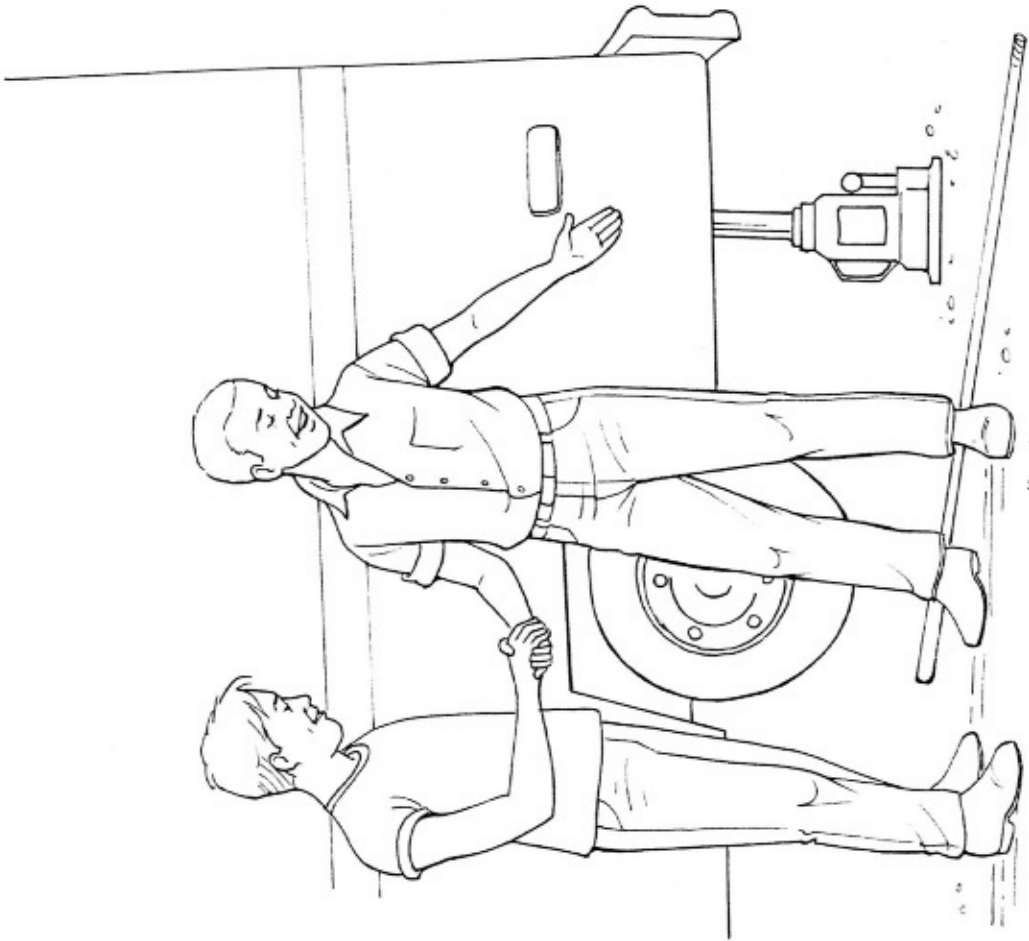

The truck budged!

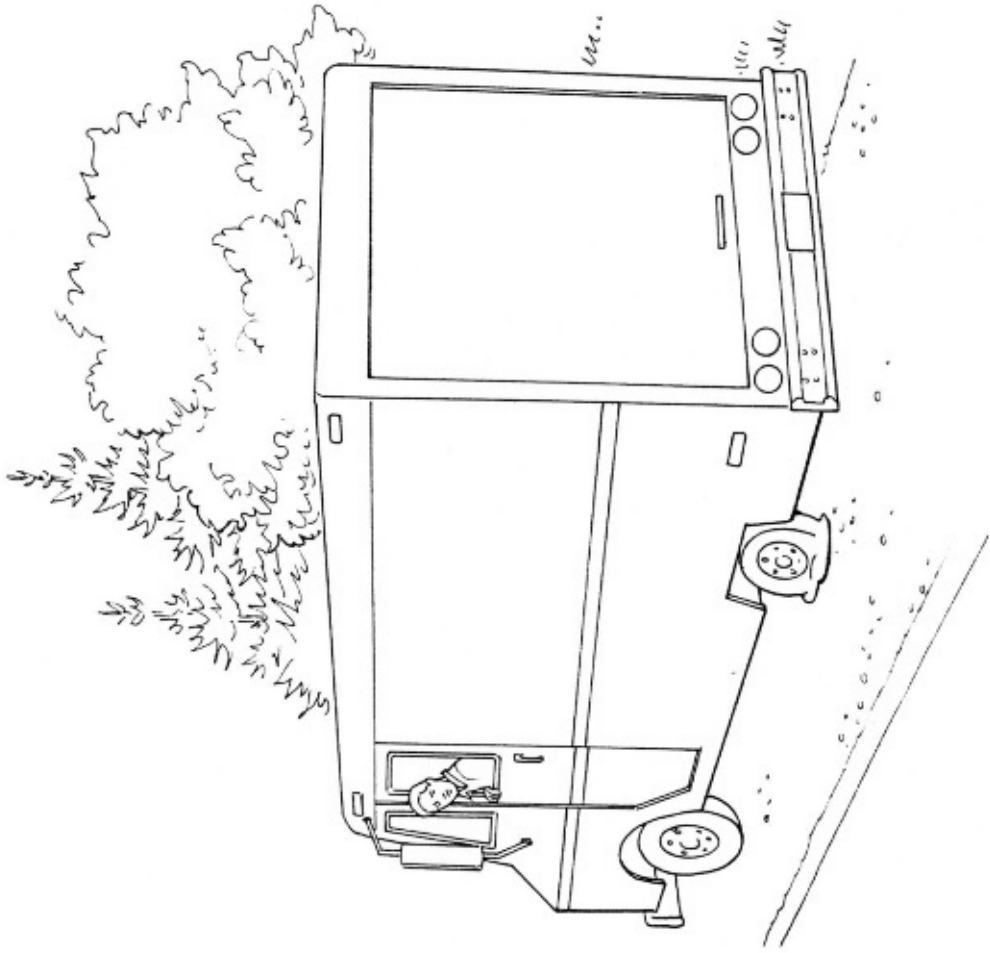

A red truck had a flat.  
It was stuck.

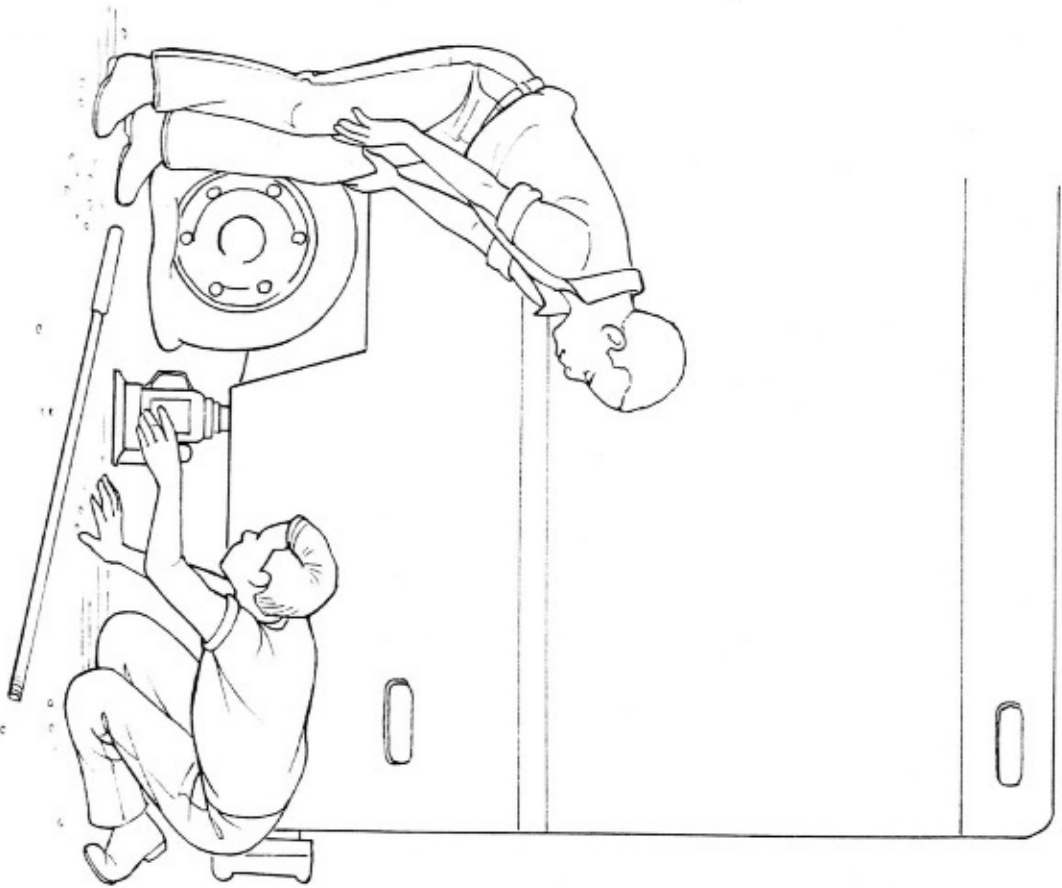

Can the men fix it?

4

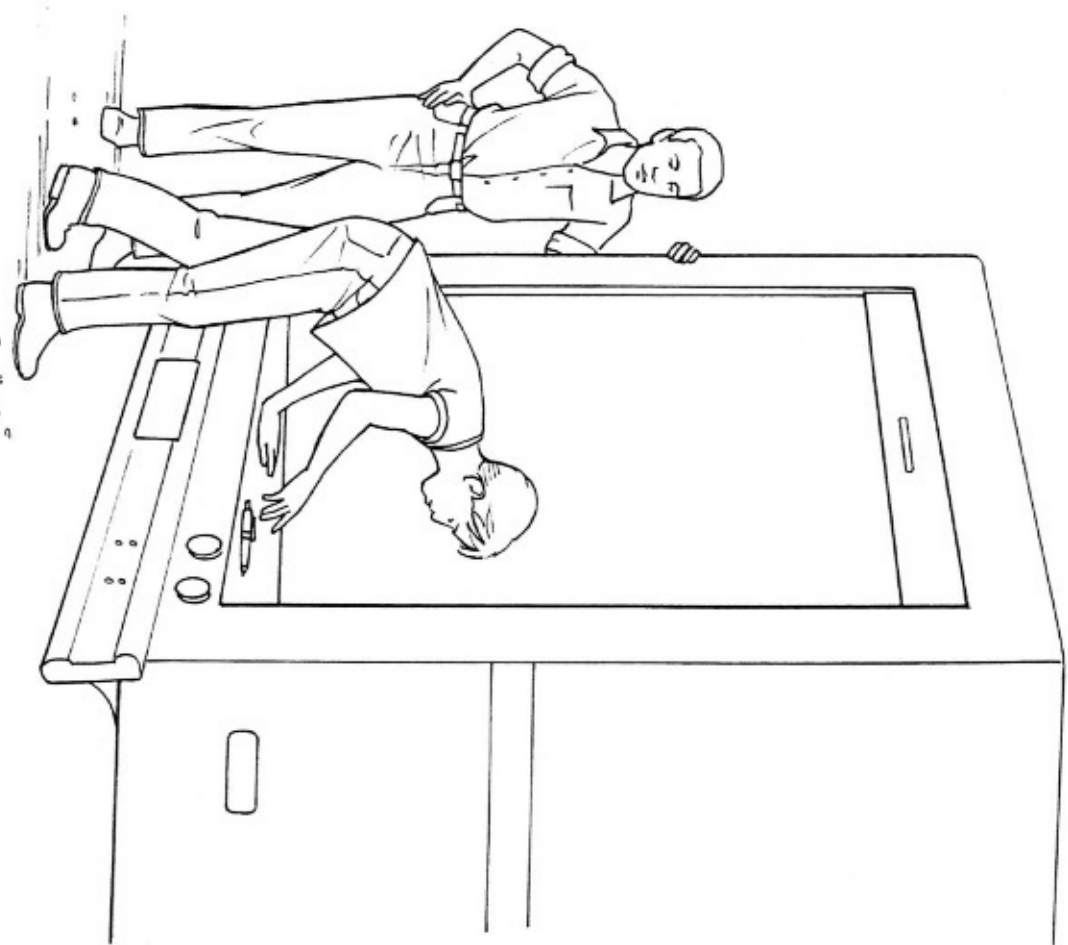

A big man picked up a red pen.

13



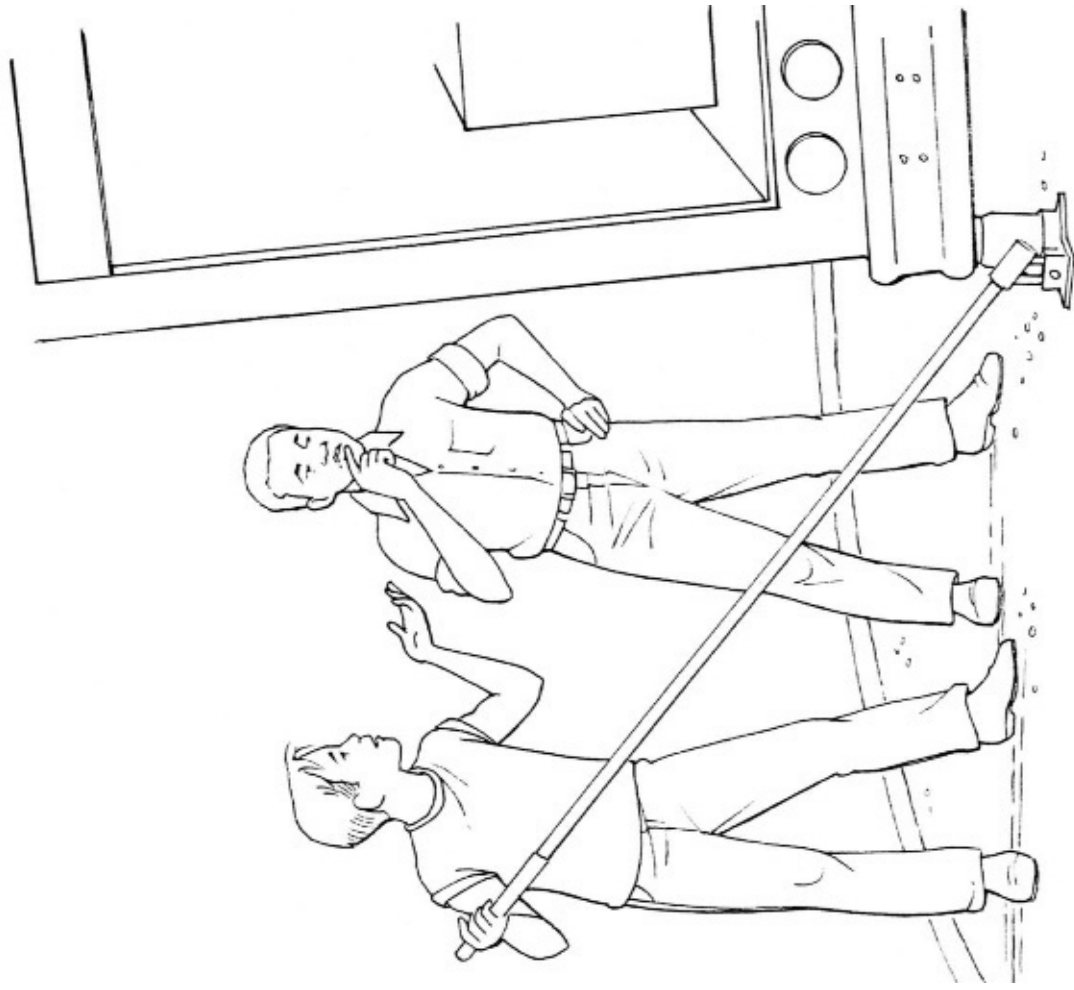

The truck still did not budge.

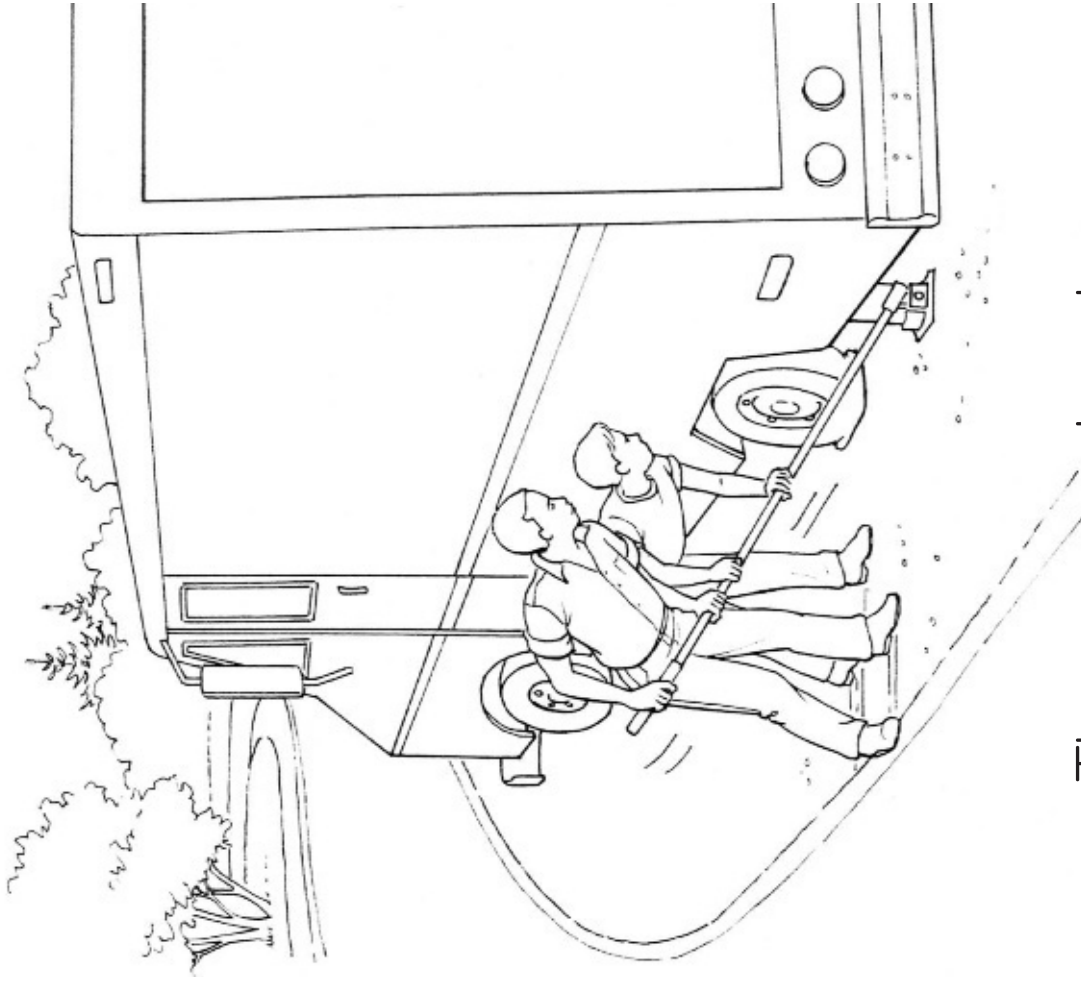

The men pumped a jack.  
The truck did not budge!

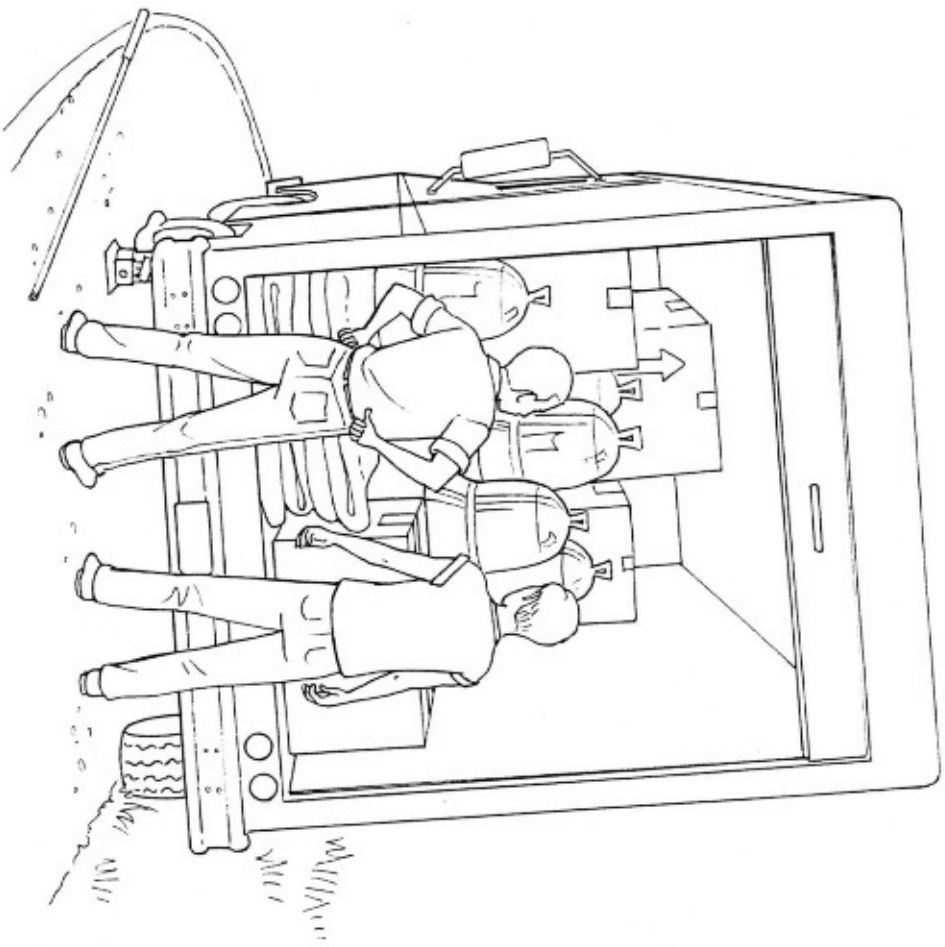

The truck was filled up.

6

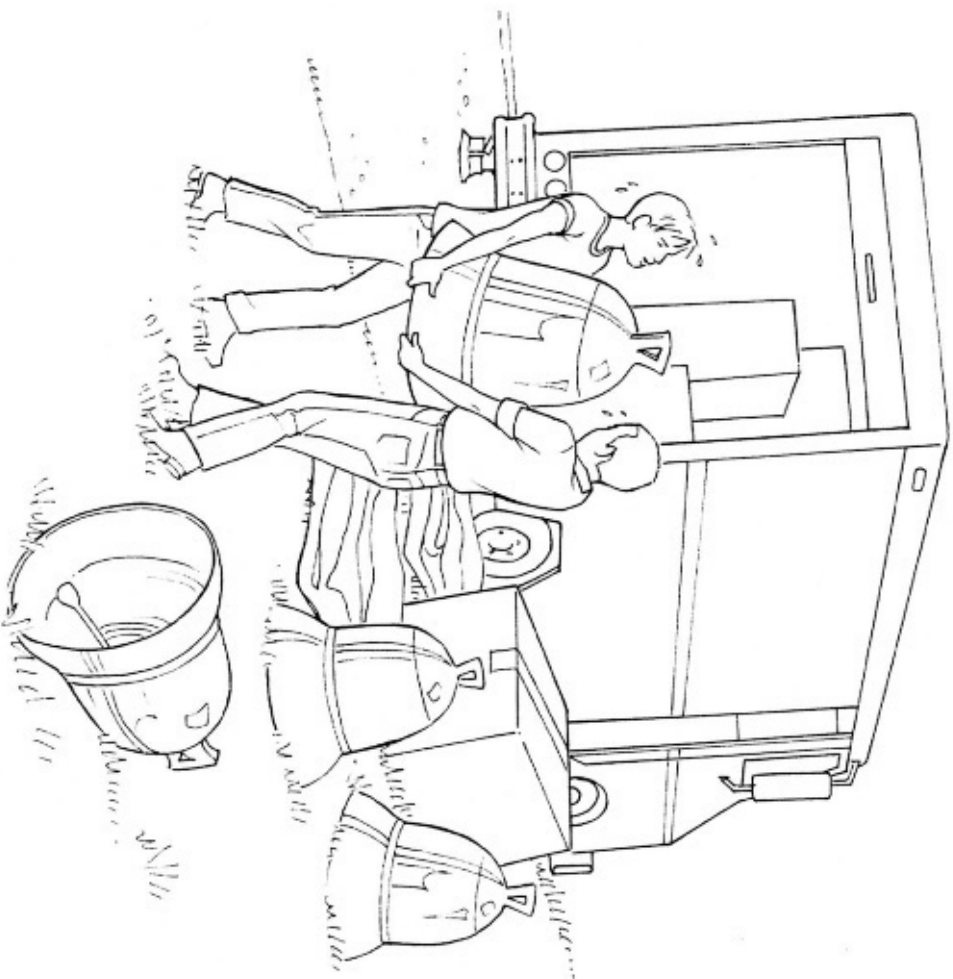

Next the men lifted six bells.

The men dumped six bells.

11

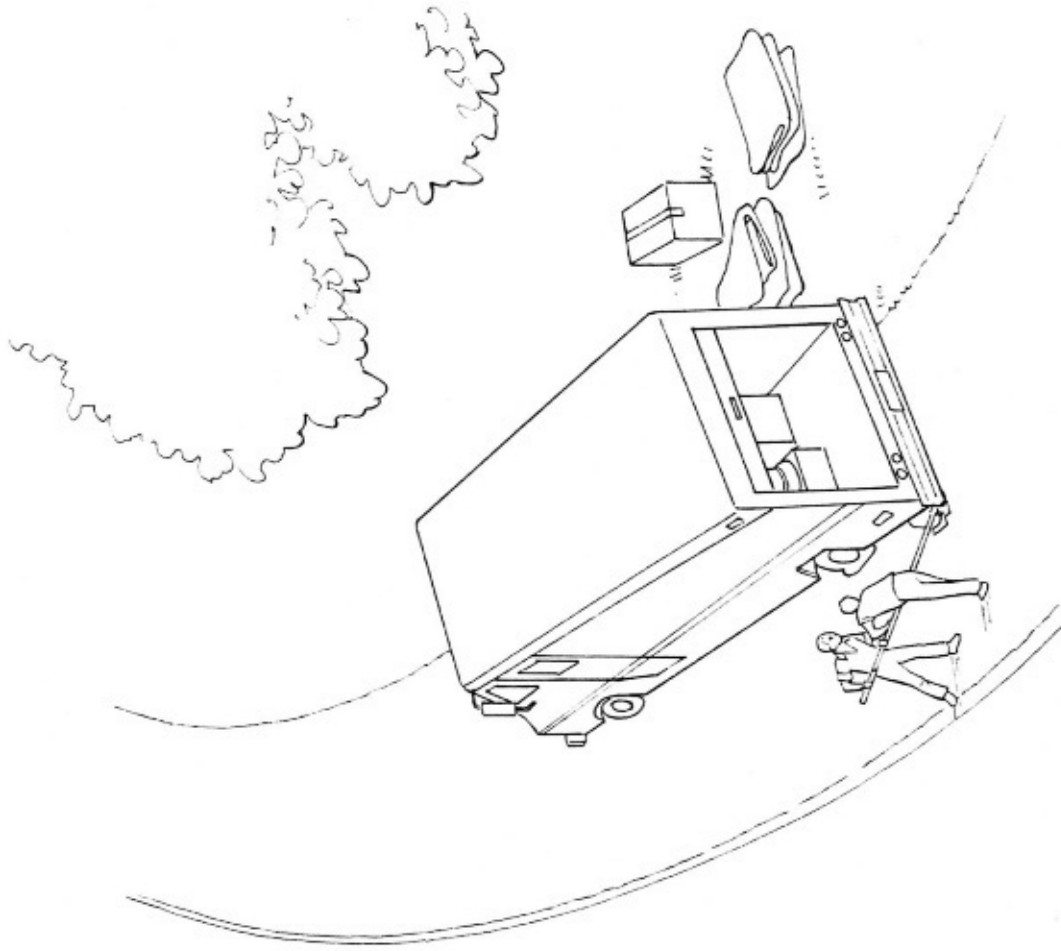

The truck did not budge!

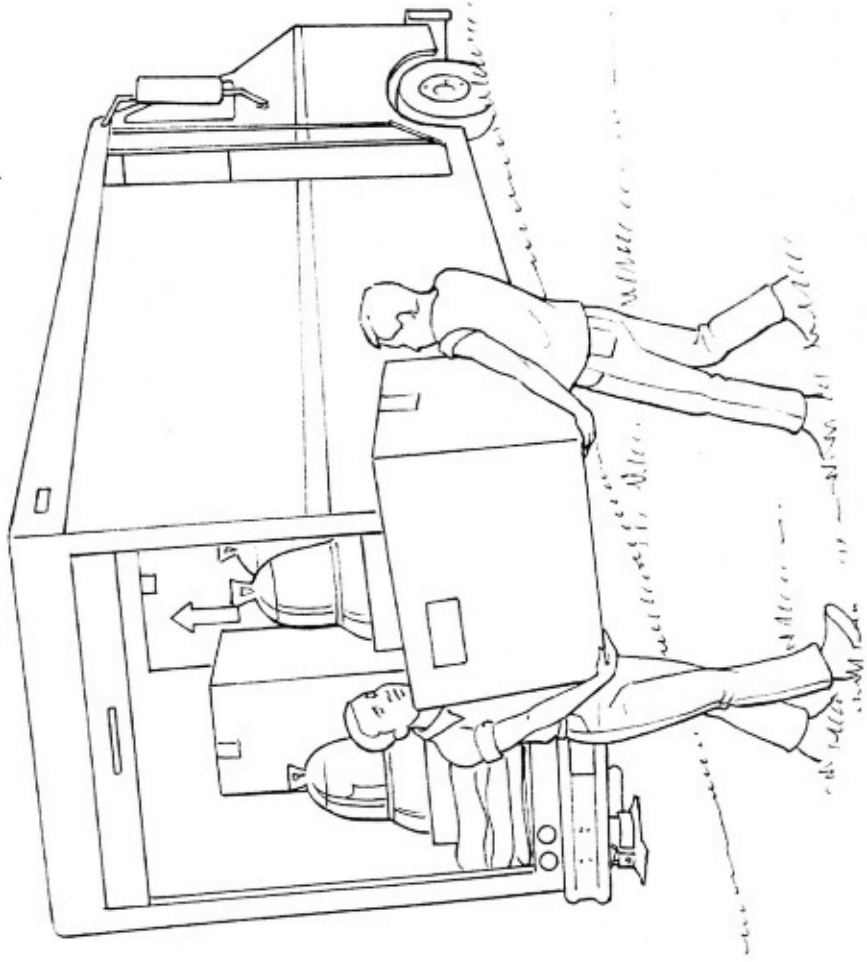

The men lifted a big box.  
The men set it down.

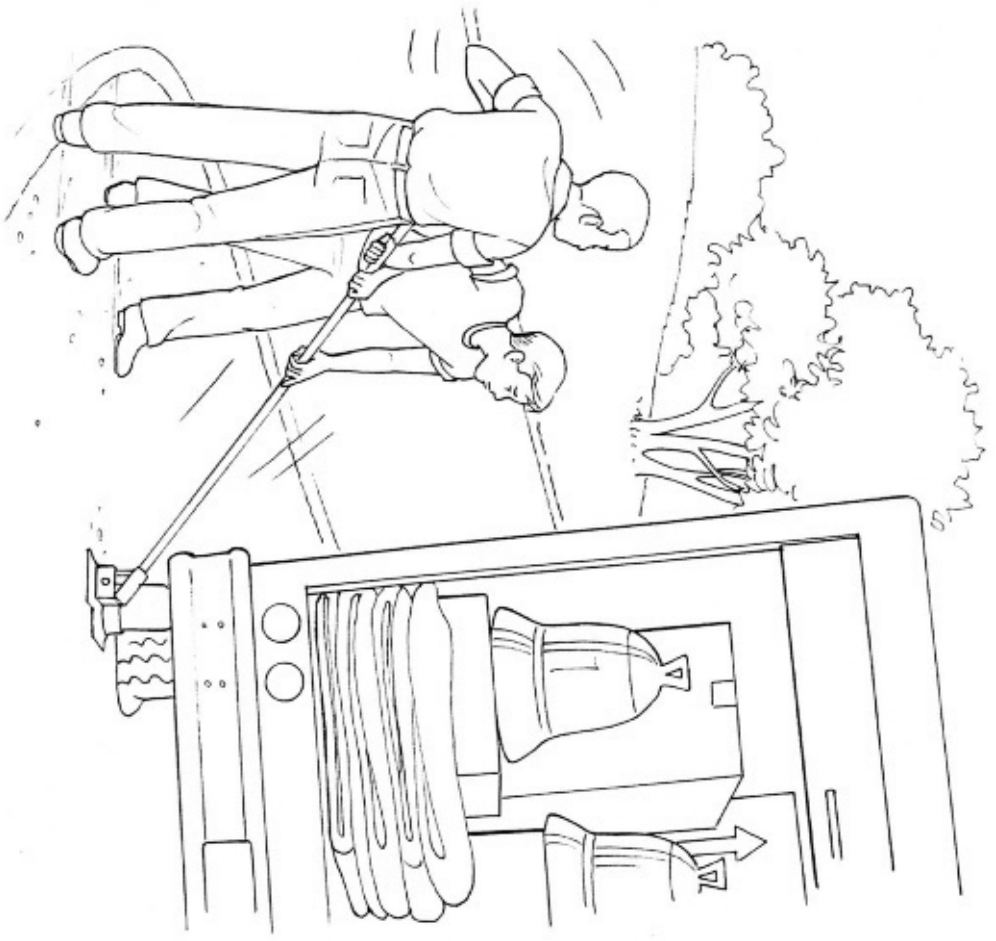

Did it help?

It did not!

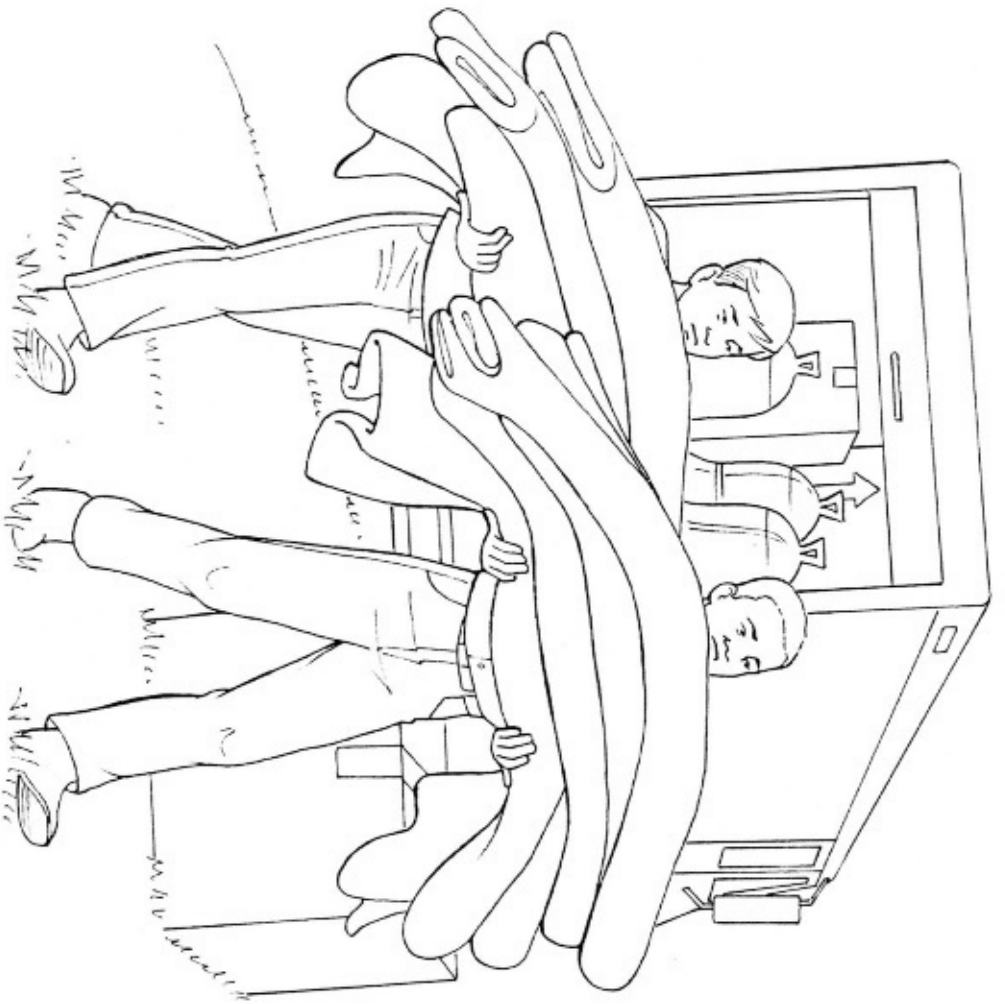

The men grabbed fabric.









Dad fixed eggs.

Then, Ted spread jam on bread.

MHEonline.com



Copyright © 2015 McGraw-Hill Education

All rights reserved. The contents, or parts thereof, may be reproduced in print form for non-profit educational use with SRA Open Court Reading, provided such reproductions bear copyright notice, but may not be reproduced in any form for any other purpose without the prior written consent of McGraw-Hill Education, including, but not limited to, network storage or transmission, or broadcast for distance learning.

Send all inquiries to:  
McGraw-Hill Education  
8787 Orion Place  
Columbus, OH 43240



Dad and Ted then headed back.



Ted printed his list.



Ted read his list.

Then, Ted got bread and milk.

4

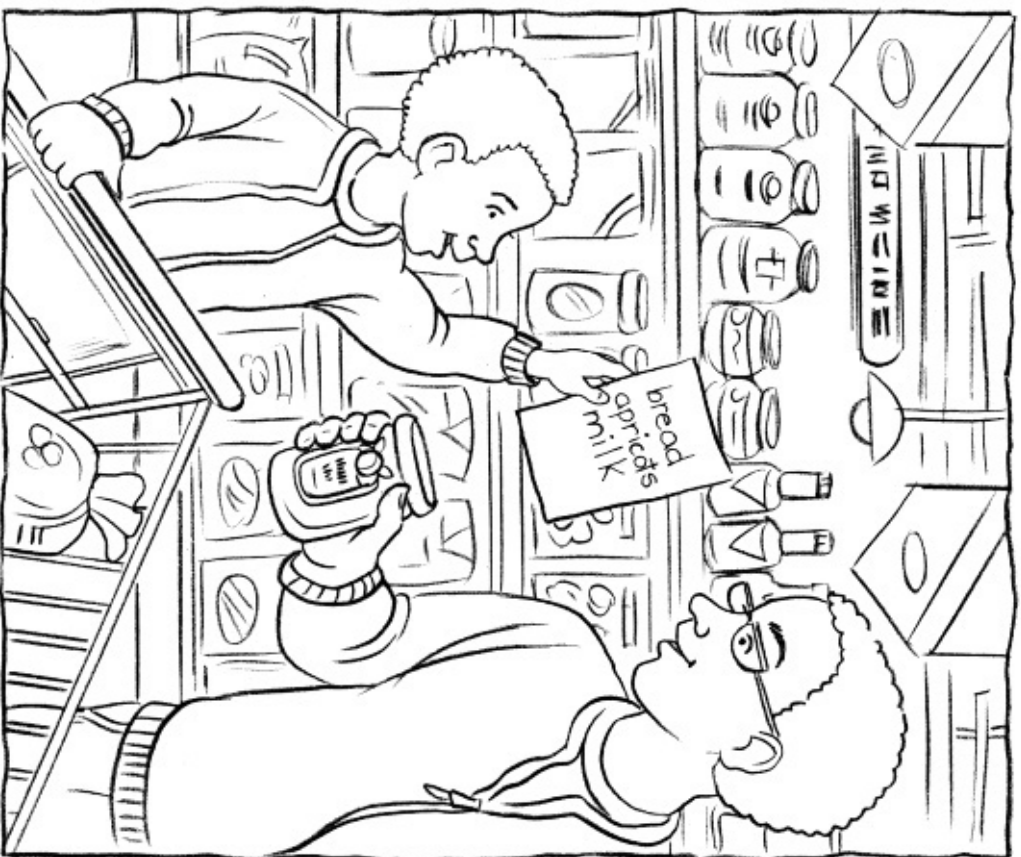

Then, Dad read.

Dad got jam instead of apricots.

5





Trish's ship splashes in the sun.

# Trish's Ship

by Ron Hart  
illustrated by Jan Pyk

Core Decodable 40



Bothell, WA • Chicago, IL • Columbus, OH • New York, NY

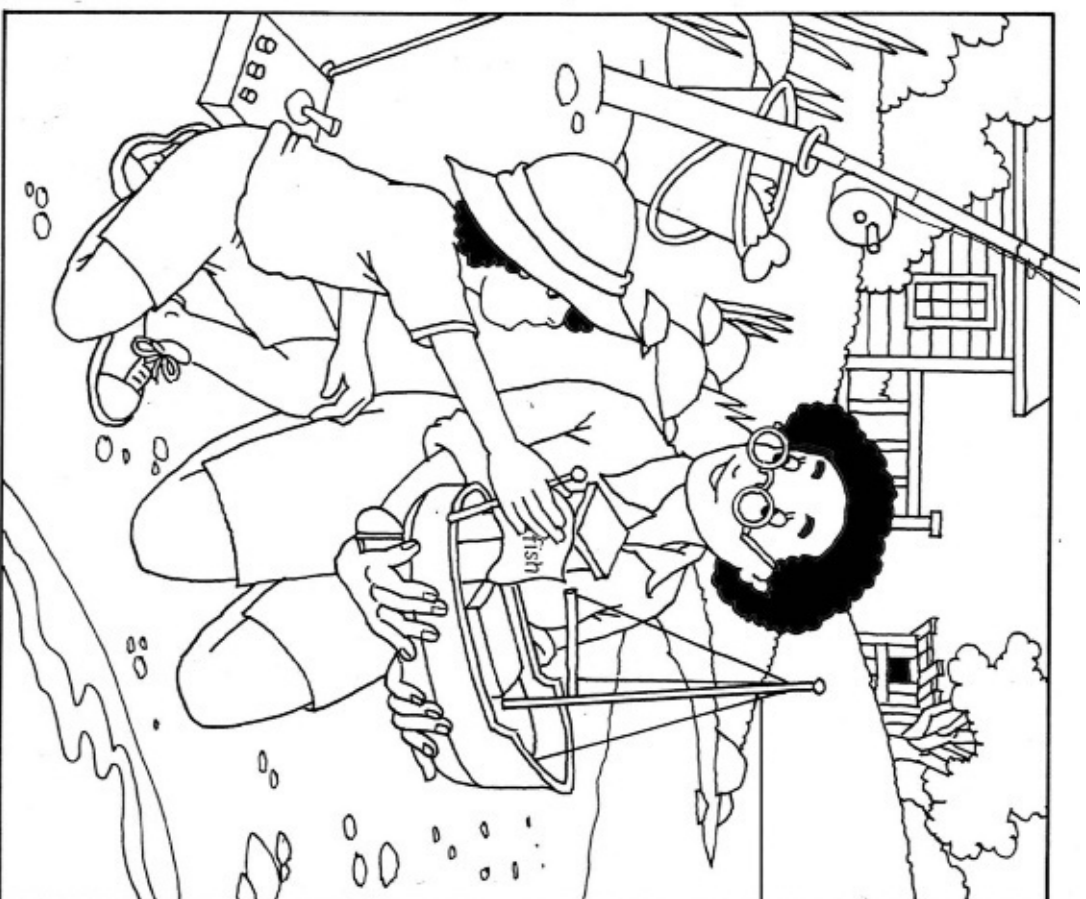

Trish calls the ship “The Shellfish.”

MHEonline.com



Copyright © 2015 McGraw-Hill Education

All rights reserved. The contents, or parts thereof, may be reproduced in print form for non-profit educational use with SRA Open Court Reading, provided such reproductions bear copyright notice, but may not be reproduced in any form for any other purpose without the prior written consent of McGraw-Hill Education, including, but not limited to, network storage or transmission, or broadcast for distance learning.

Send all inquiries to:  
McGraw-Hill Education  
8787 Orion Place  
Columbus, OH 43240





Trish has a plan. Trish gets Mom.

Trish brushes the sand.

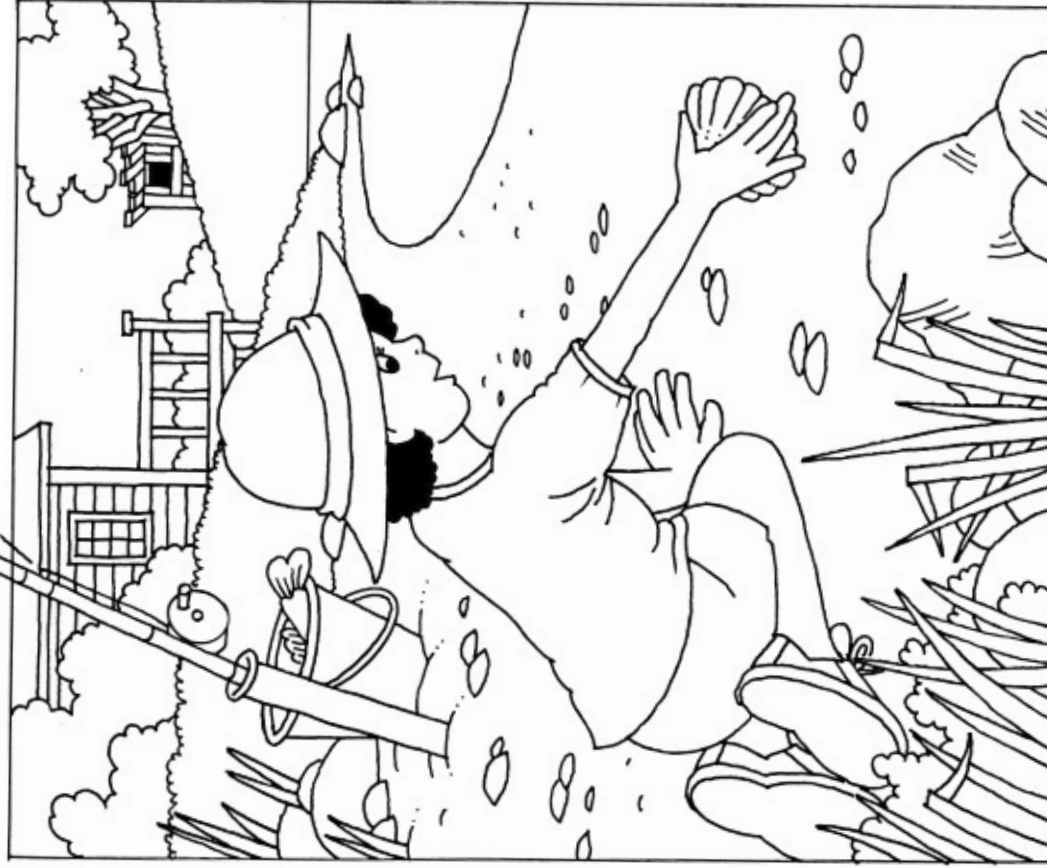

Trish fishes.

Trish picks up shells.

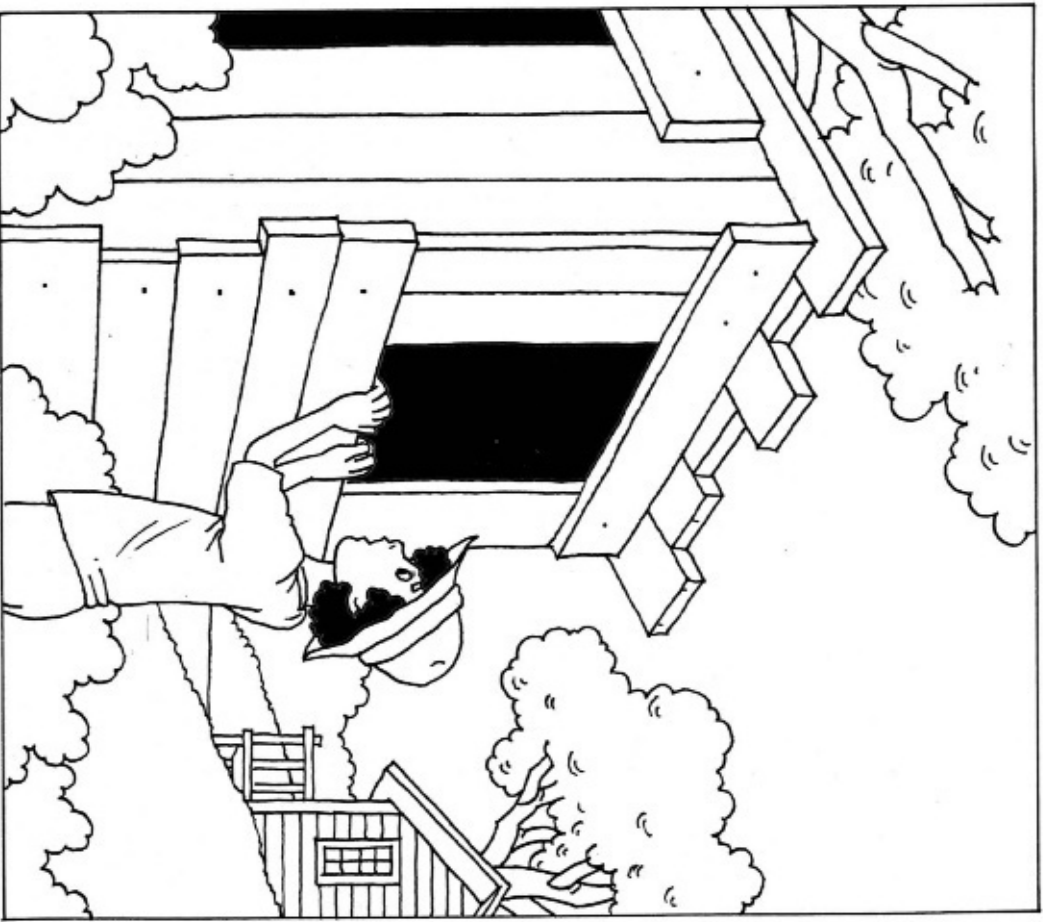

Can Trish spot a ship?

Is it stashed in the shed?

4



It is! A ship is stashed in the shed.

5

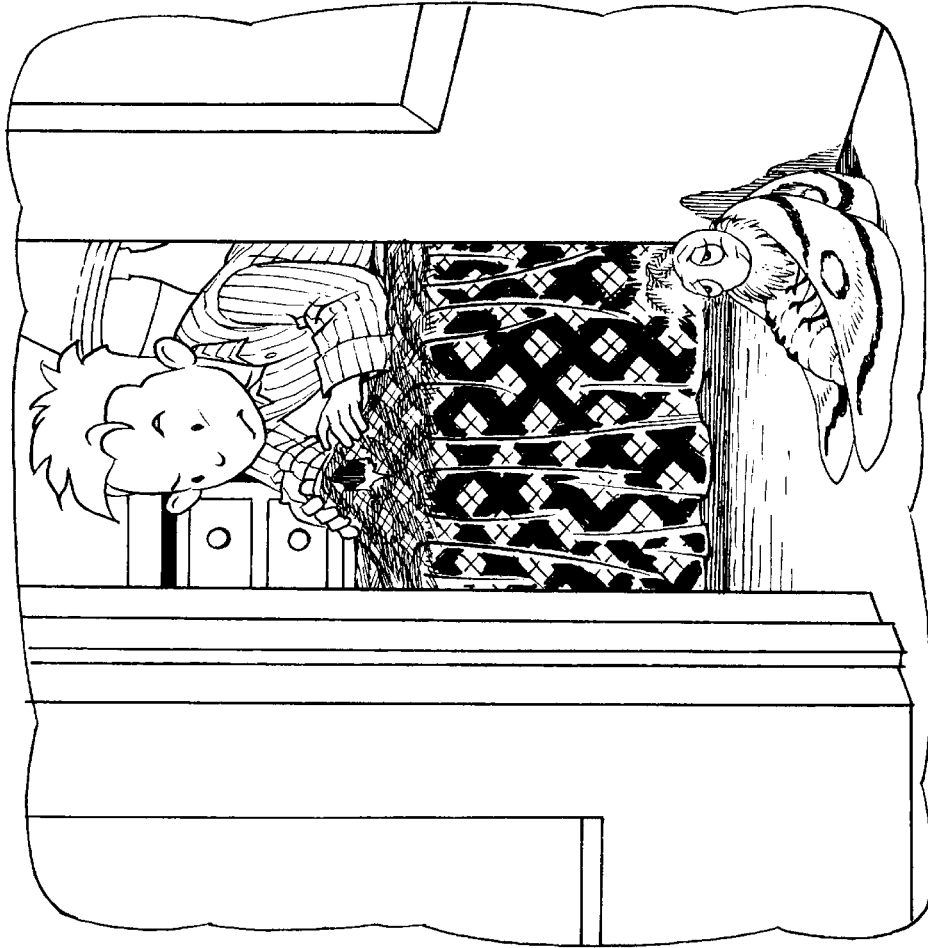

Beth is not thin.  
Thick thread is in Beth!

# Beth Gets a Snack

by Trisha Roberts  
illustrated by Shawn McManus

Core Decodable 41



Bothell, WA • Chicago, IL • Columbus, OH • New York, NY

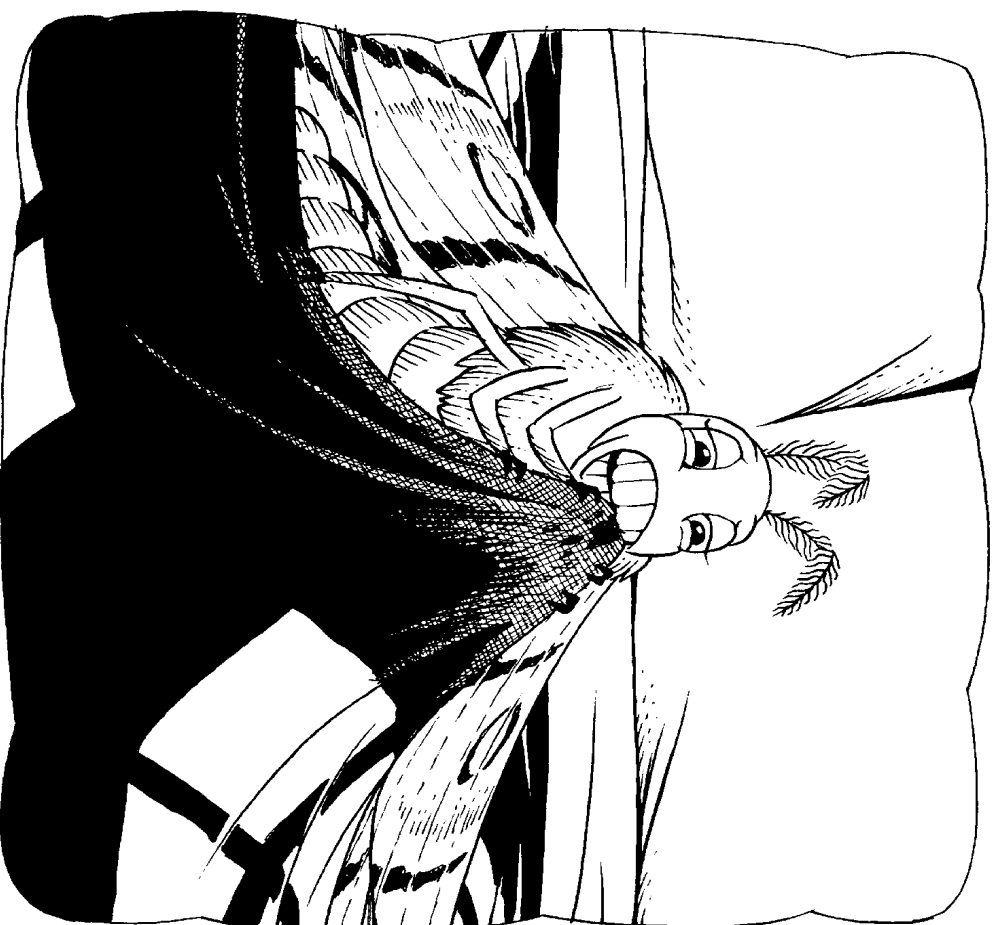

Beth is thrilled!  
Seth's bedspread is a snack.

MHEonline.com



Copyright © 2015 McGraw-Hill Education

All rights reserved. The contents, or parts thereof, may be reproduced in print form for non-profit educational use with SRA Open Court Reading, provided such reproductions bear copyright notice, but may not be reproduced in any form for any other purpose without the prior written consent of McGraw-Hill Education, including, but not limited to, network storage or transmission, or broadcast for distance learning.

Send all inquiries to:  
McGraw-Hill Education  
8787 Orion Place  
Columbus, OH 43240

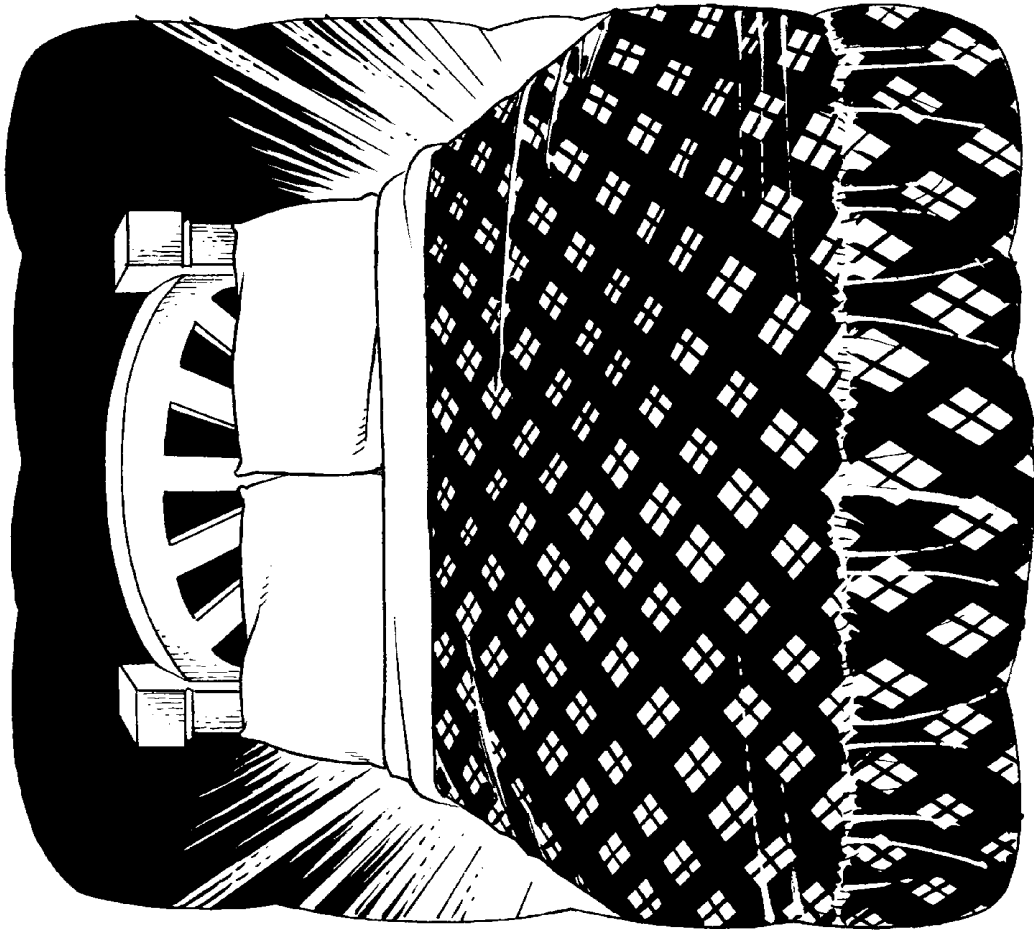

Seth has a bedspread.  
That bedspread has thick threads.

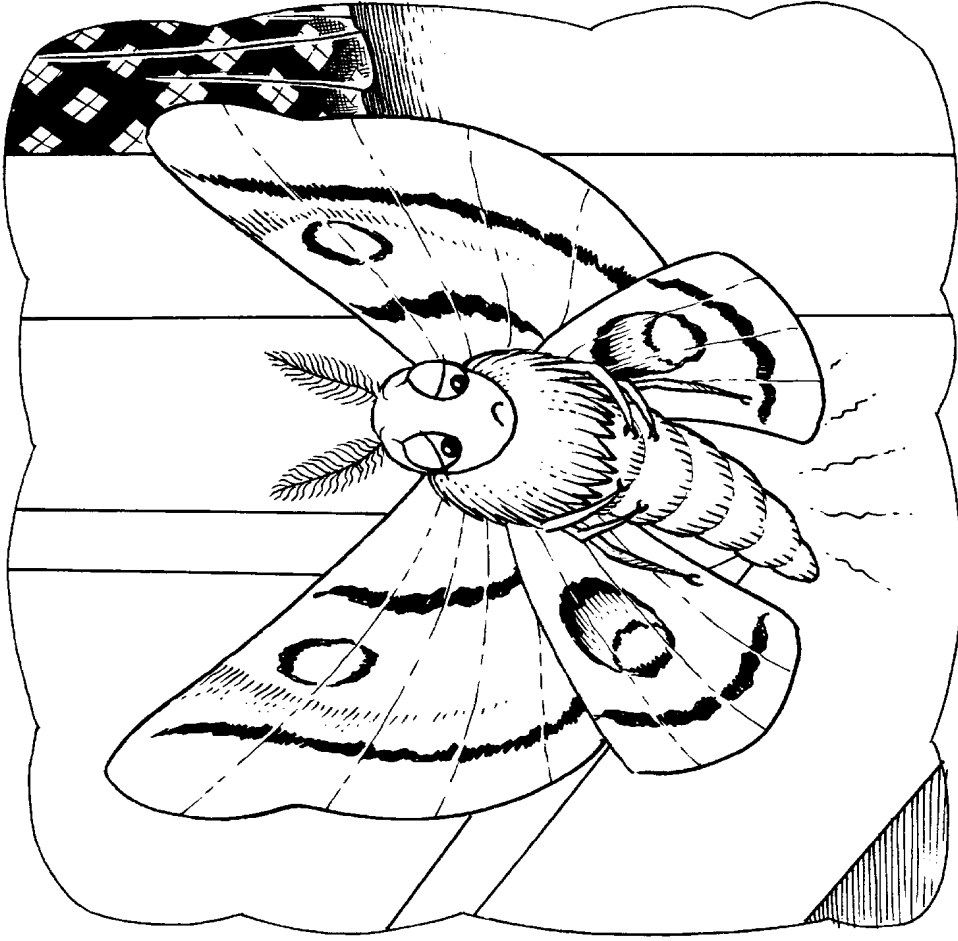

Beth is a thin bug.  
Can Beth have a snack?



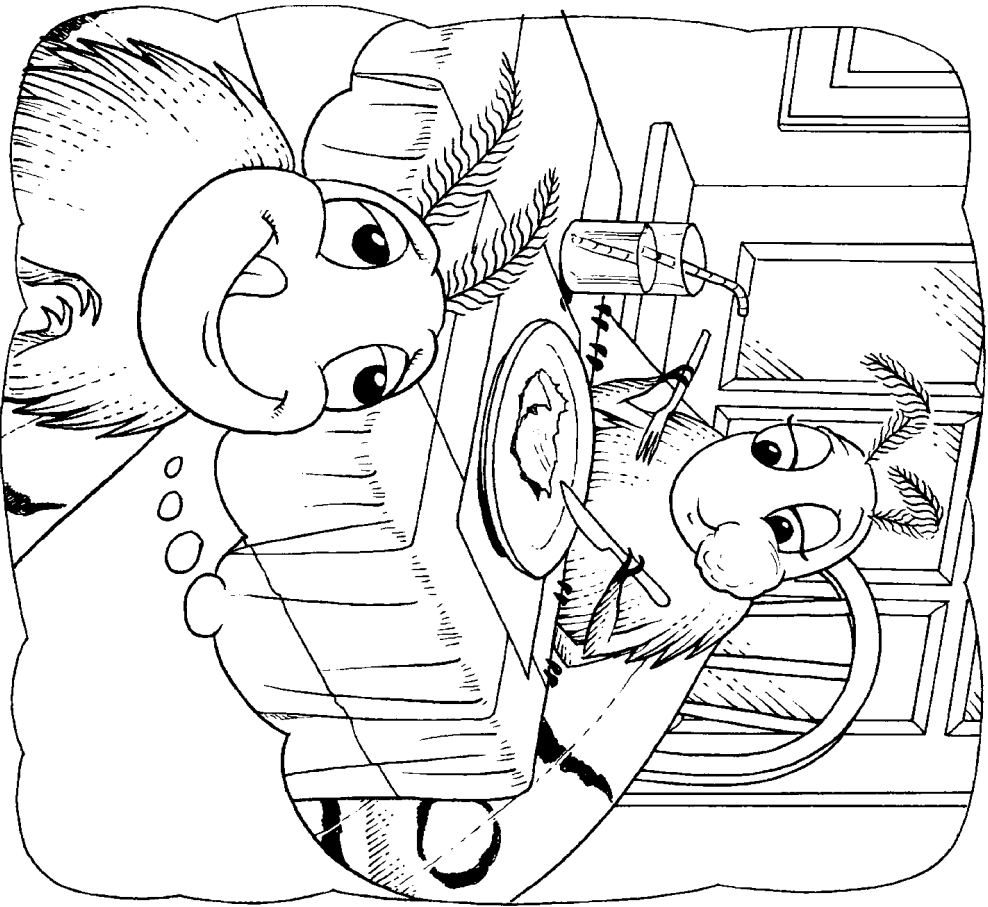

Is fabric a snack?

Beth can get fabric.

4

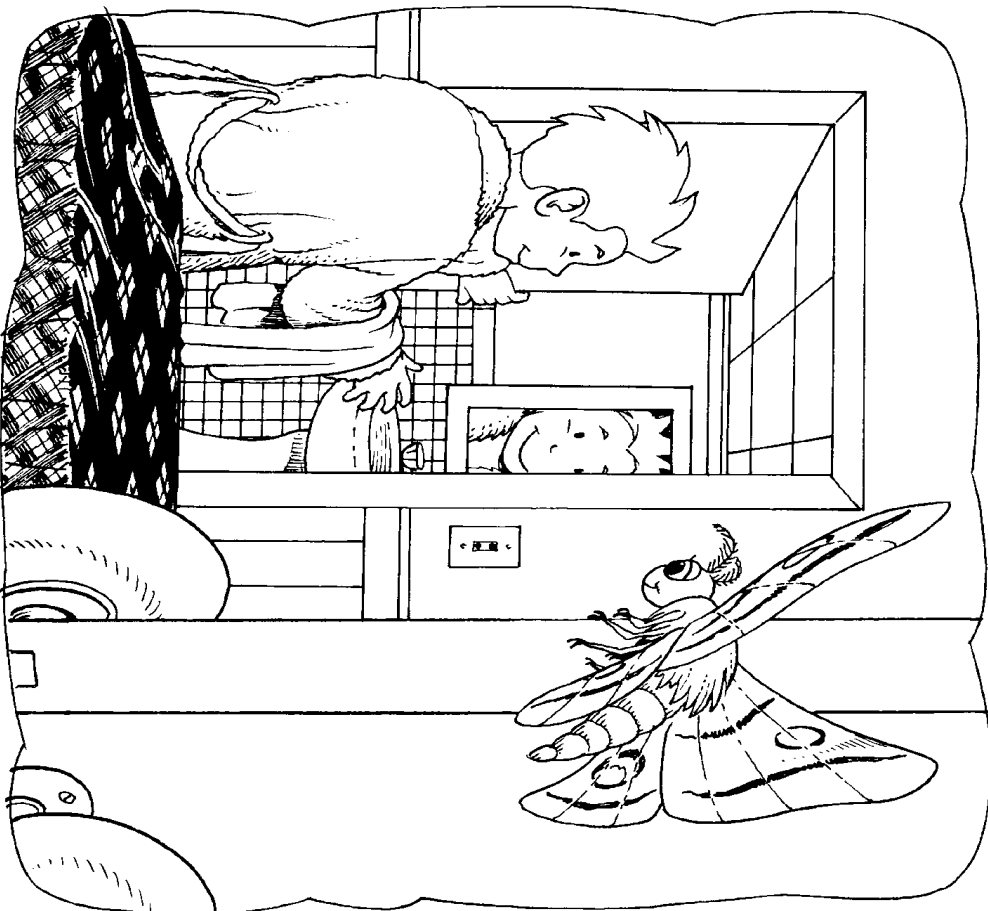

This is Seth.

Seth gets a bath.

5



Dad pats Patch.  
Mitch gets Patch a snack.

# Mitch on a Ranch

by Rhonda Martin  
illustrated by Meryl Henderson  
Core Decodable 42



Bothell, WA • Chicago, IL • Columbus, OH • New York, NY

MHEonline.com



Copyright © 2015 McGraw-Hill Education

All rights reserved. The contents, or parts thereof, may be reproduced in print form for non-profit educational use with *SRA Open Court Reading*, provided such reproductions bear copyright notice, but may not be reproduced in any form for any other purpose without the prior written consent of McGraw-Hill Education, including, but not limited to, network storage or transmission, or broadcast for distance learning.

Send all inquiries to:  
McGraw-Hill Education  
8787 Orion Place  
Columbus, OH 43240

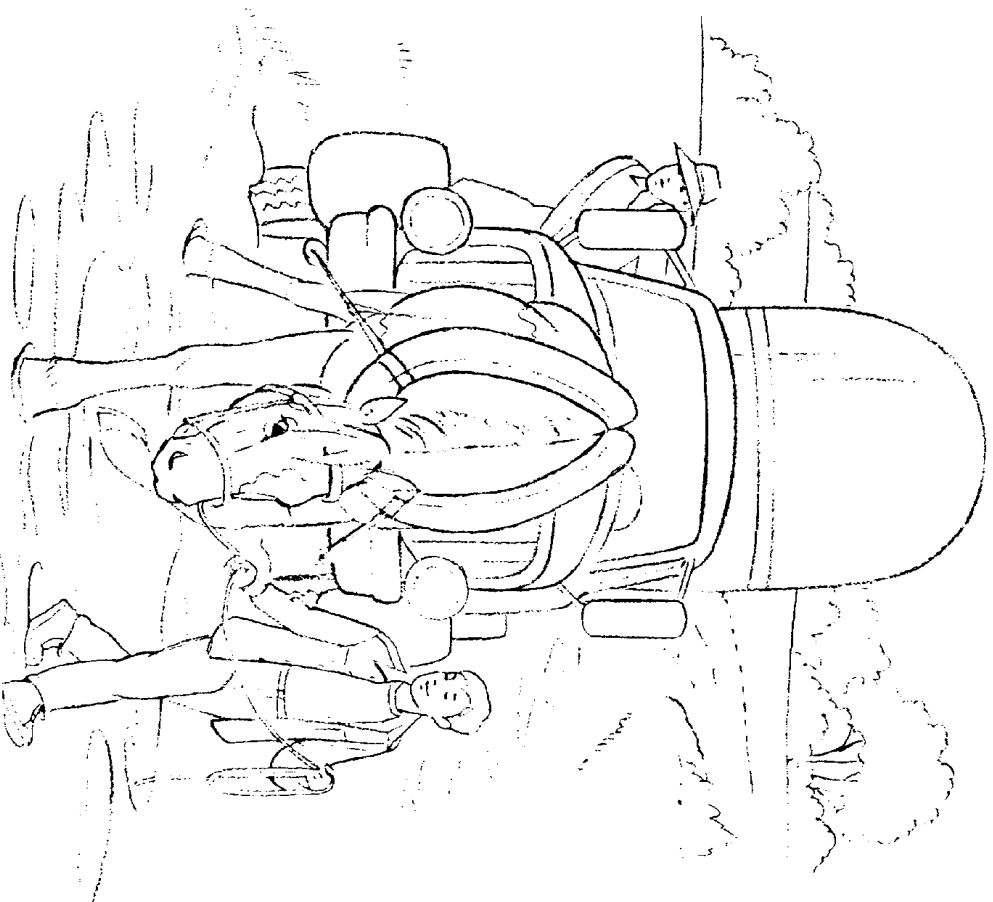

Patch catches on and helps.  
The truck is not in the ditch.

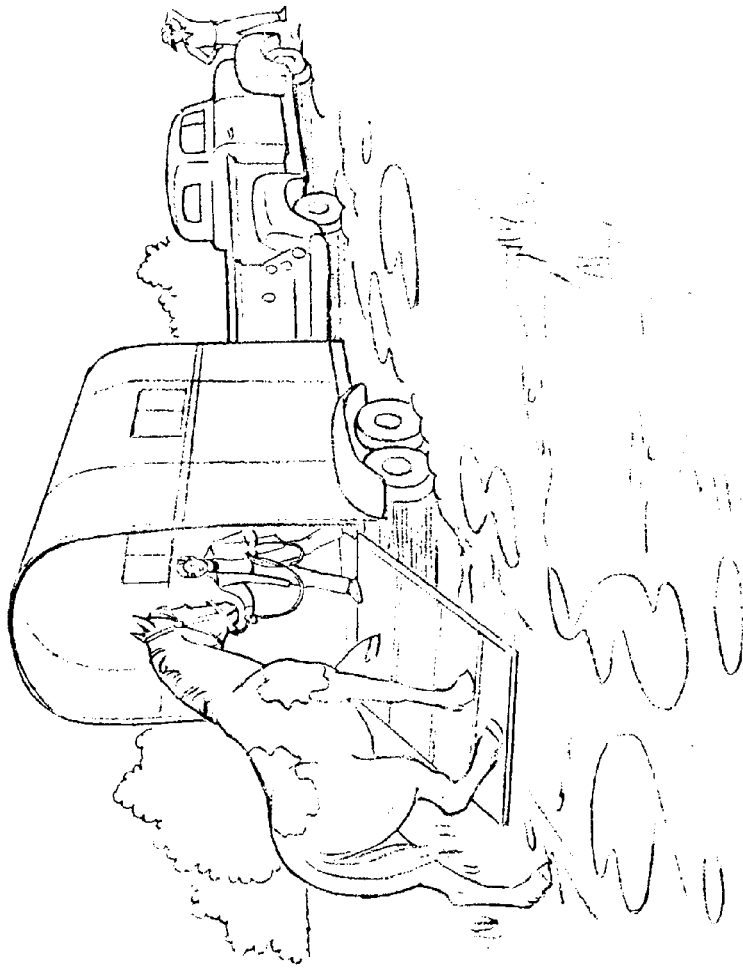

Dad's truck is stuck in a ditch!  
Mitch fetches Patch.

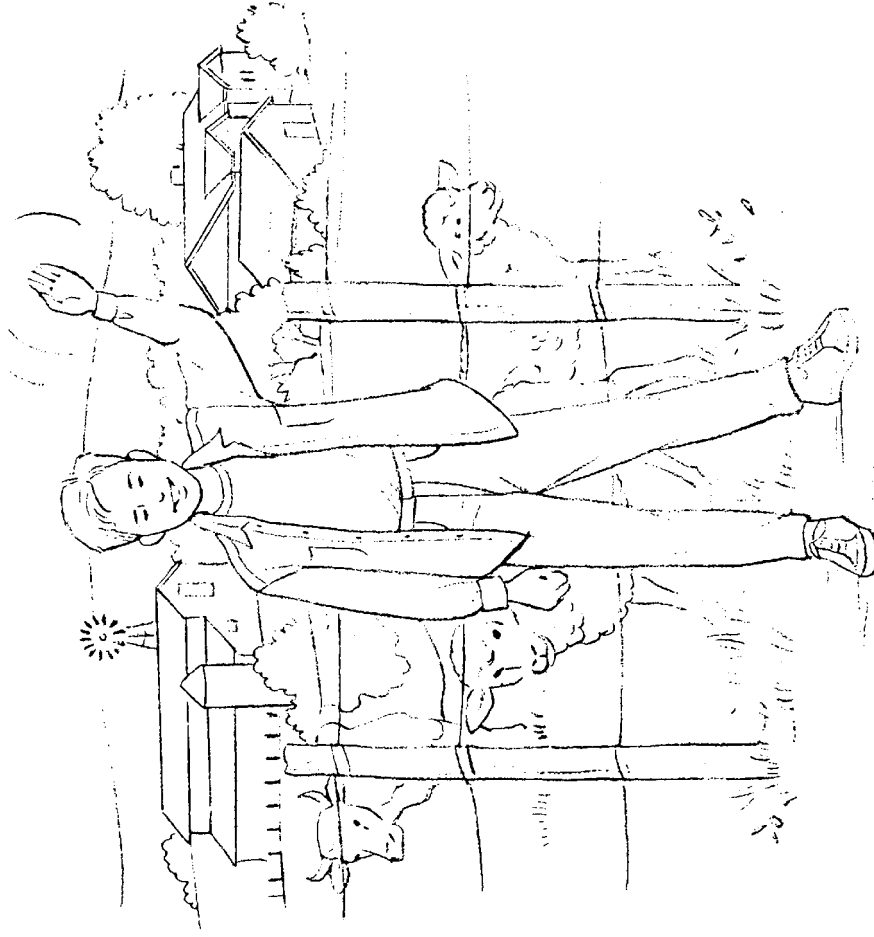

This is Mitch.  
Mitch is on a ranch.

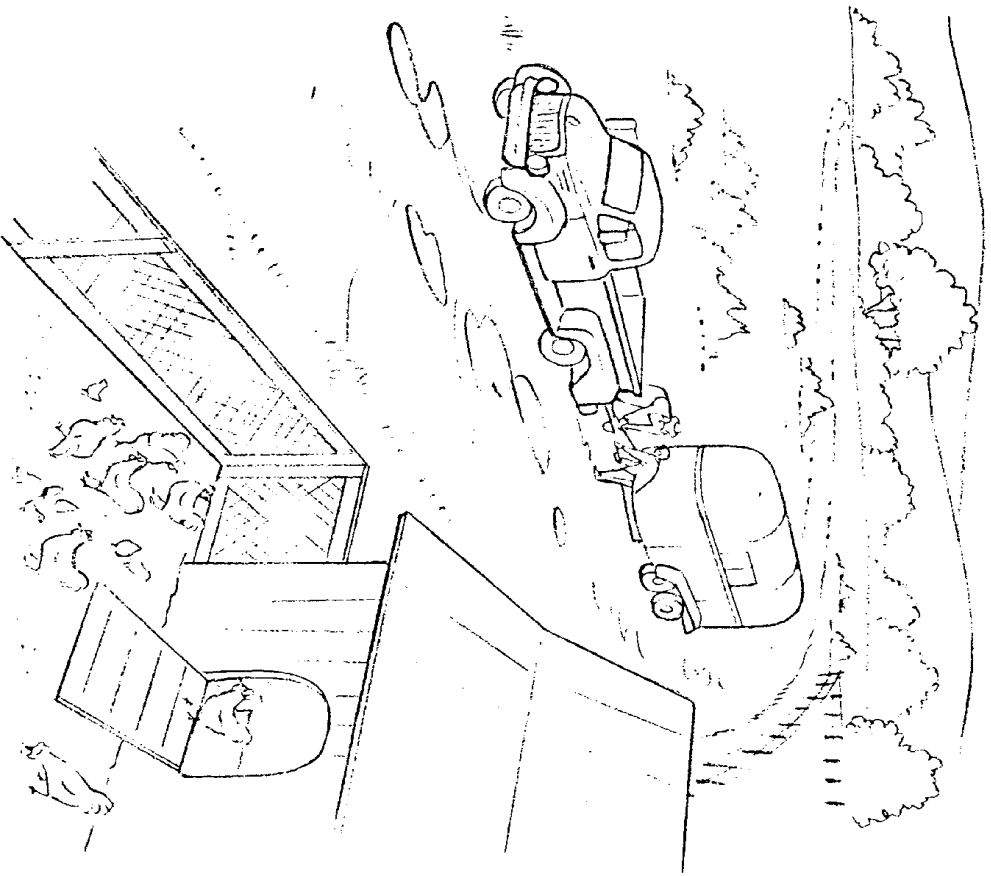

Mitch helps Dad hitch up the truck.

4



Mitch checks on the chicks.  
This chick just hatched.

5



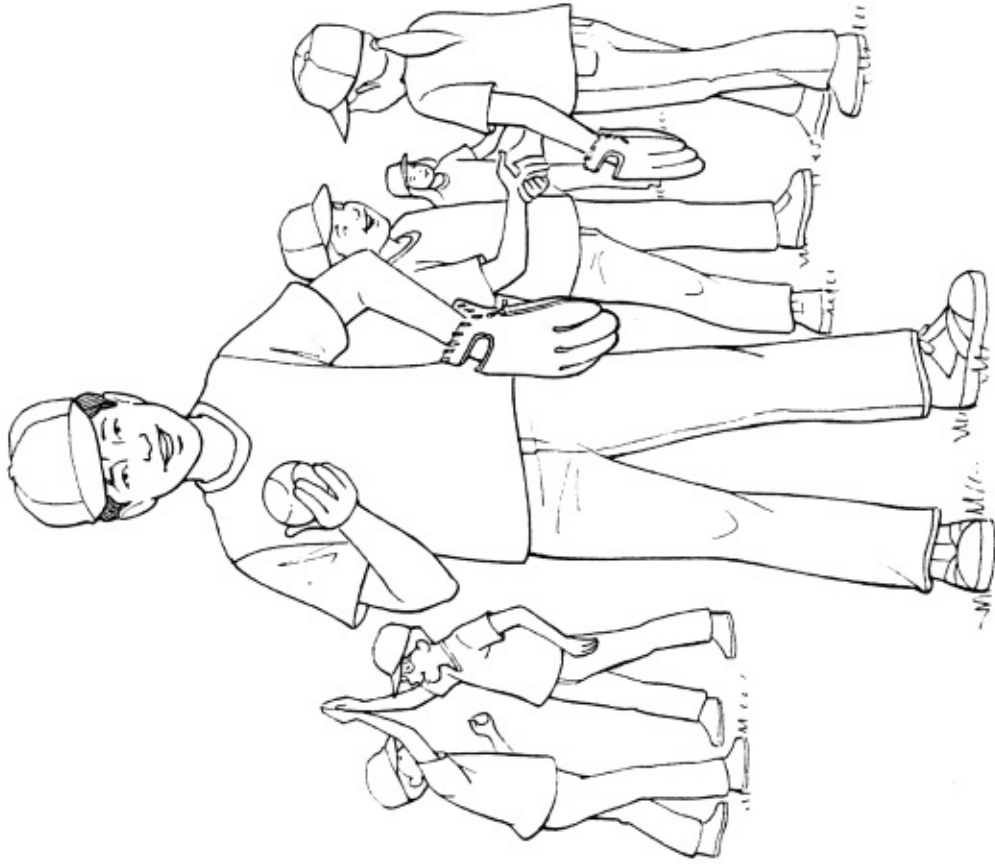

“It was fun on the bench,” said Mitch.

“And it is fun to hit, pitch, and catch!”

# Ball Camp

by Antonio Colantoni  
illustrated by Meryl Henderson

Core Decodable 43



Bothell, WA • Chicago, IL • Columbus, OH • New York, NY

MHEonline.com



Copyright © 2015 McGraw-Hill Education

All rights reserved. The contents, or parts thereof, may be reproduced in print form for non-profit educational use with *SRA Open Court Reading*, provided such reproductions bear copyright notice, but may not be reproduced in any form for any other purpose without the prior written consent of McGraw-Hill Education, including, but not limited to, network storage or transmission, or broadcast for distance learning.

Send all inquiries to:  
McGraw-Hill Education  
8787 Orion Place  
Columbus, OH 43240

2



Mitch jumps to catch the ball!  
Beth, Trish, and Chad jump and clap.

15

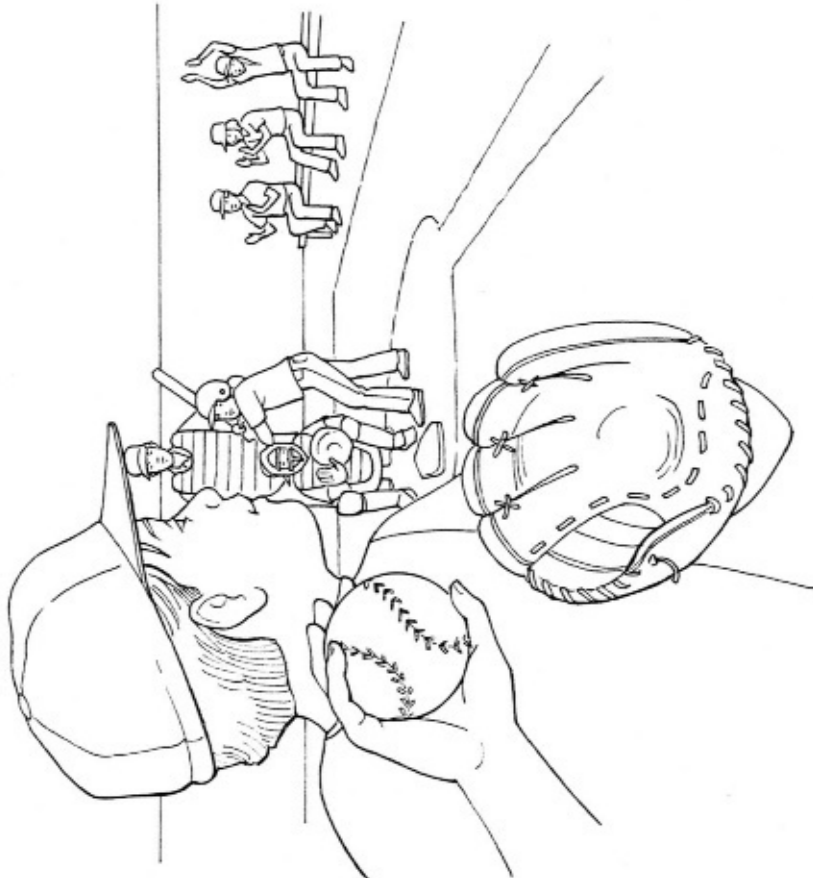

Next, Mitch gets to pitch.  
Beth, Trish, and Chad clap.

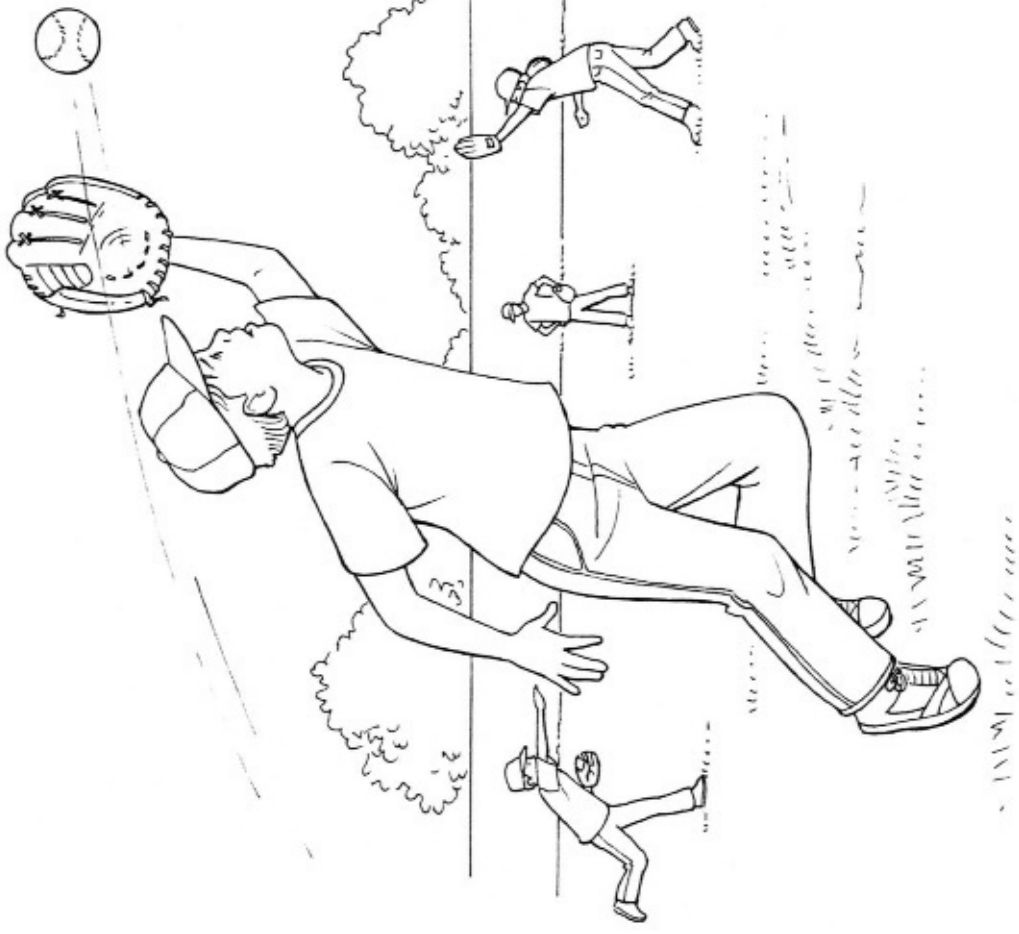

Mitch is at ball camp.

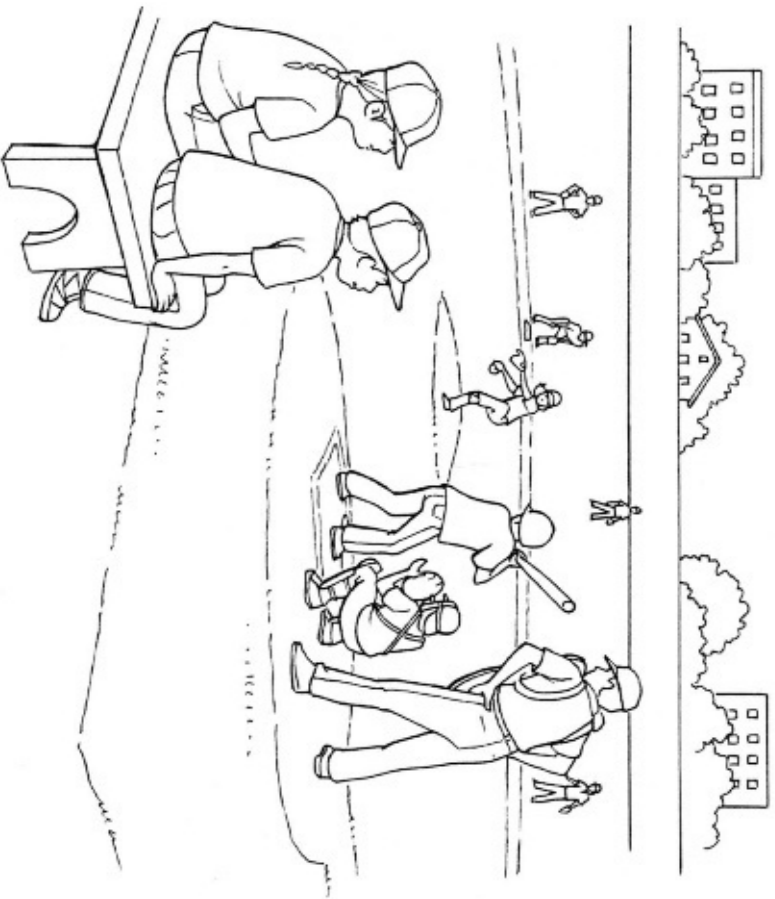

Mitch is not the best.

Mitch sits on the bench.

4

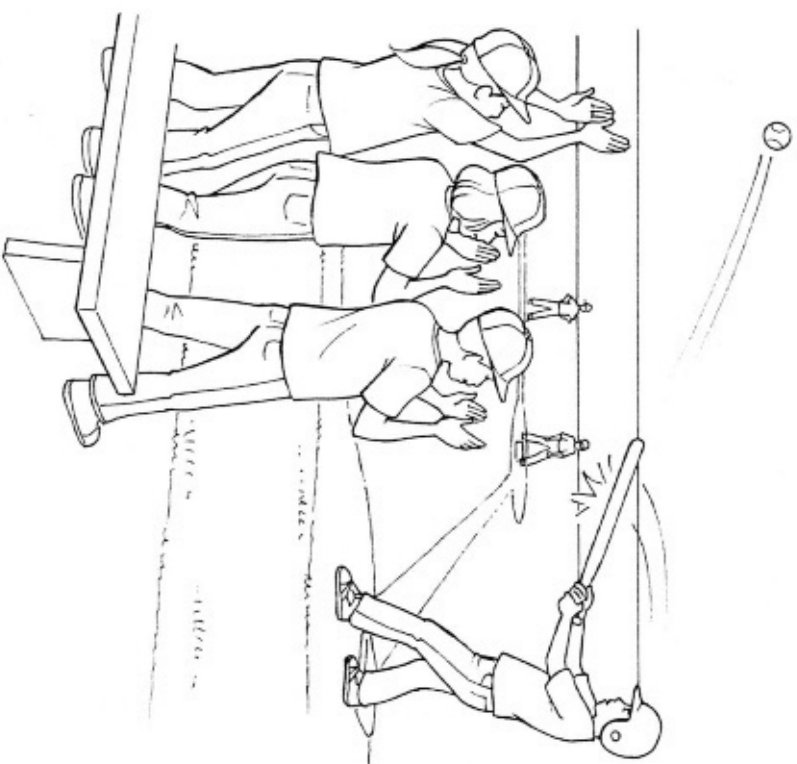

Smash! Mitch hits it!

Beth, Trish, and Chad jump and clap.

13

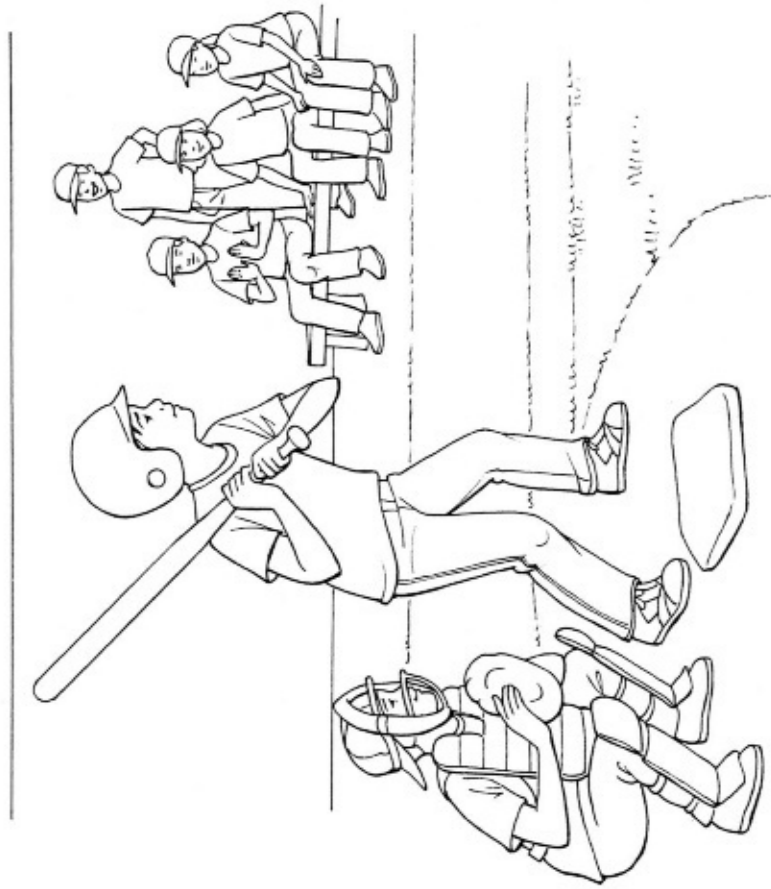

Beth, Trish, and Chad sit on the bench.  
The pitch to Mitch is fast.

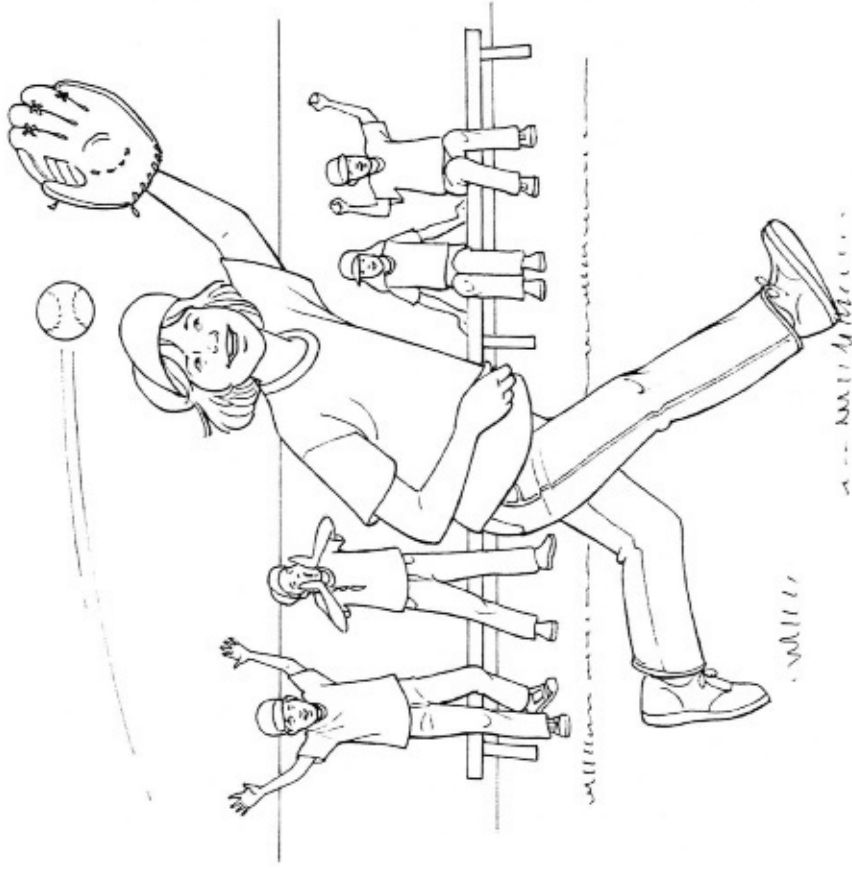

Beth can run fast and catch.



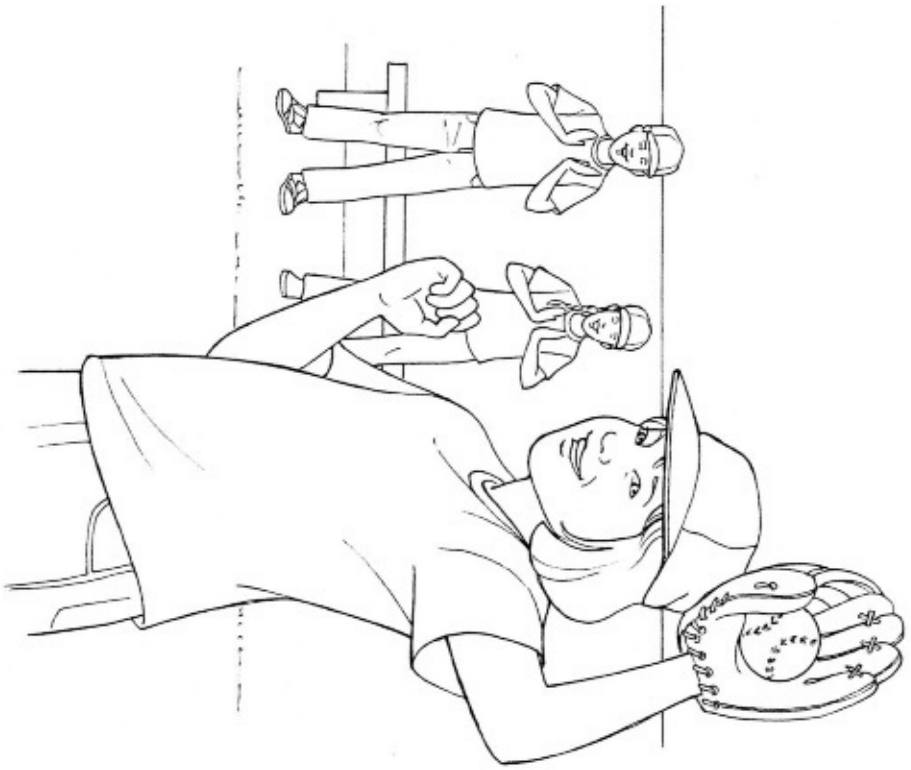

On the bench, Mitch and Liz clap.

6

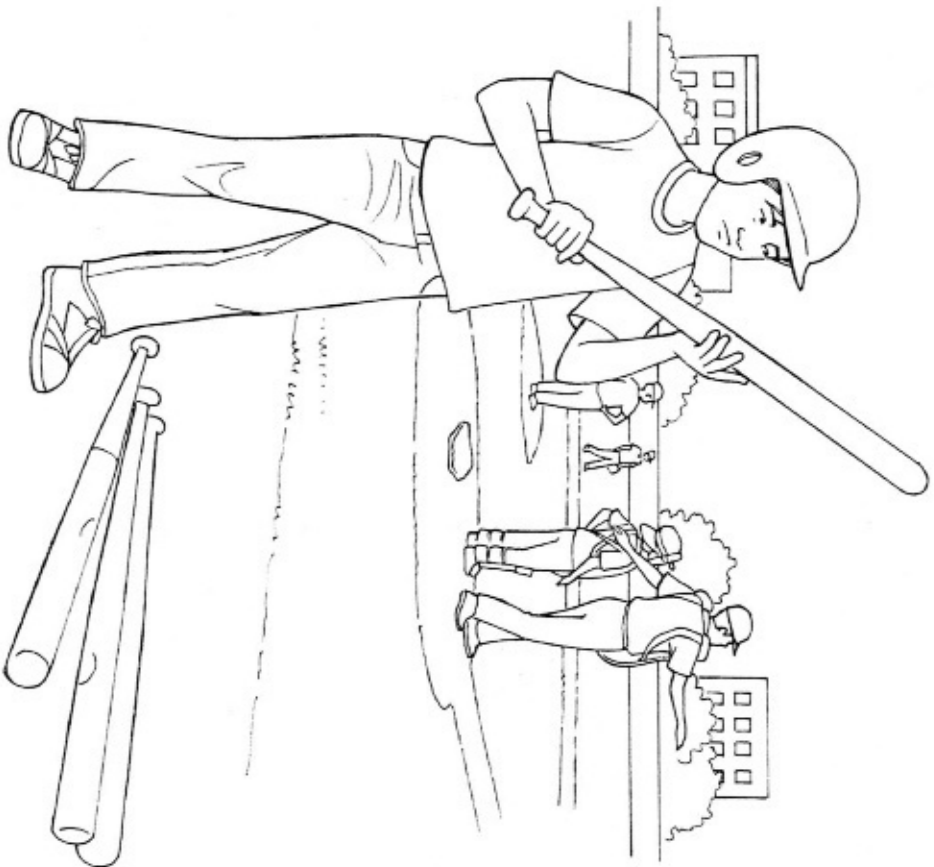

Then Mitch gets to bat.  
Mitch picks a thin bat.

11

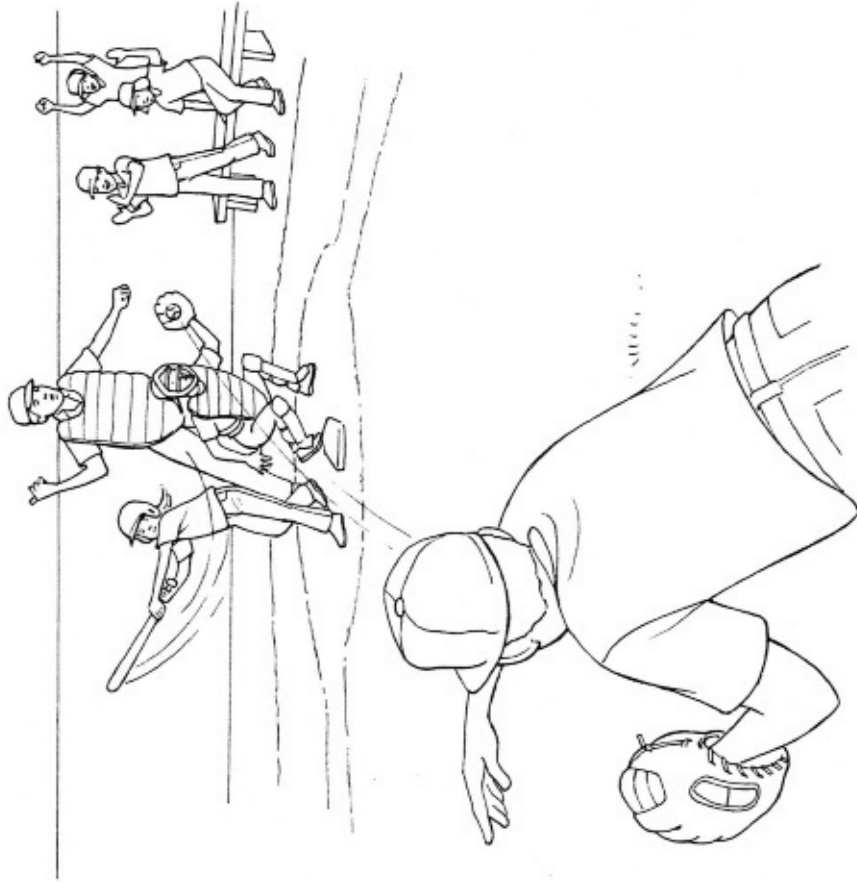

Mitch stands and claps.

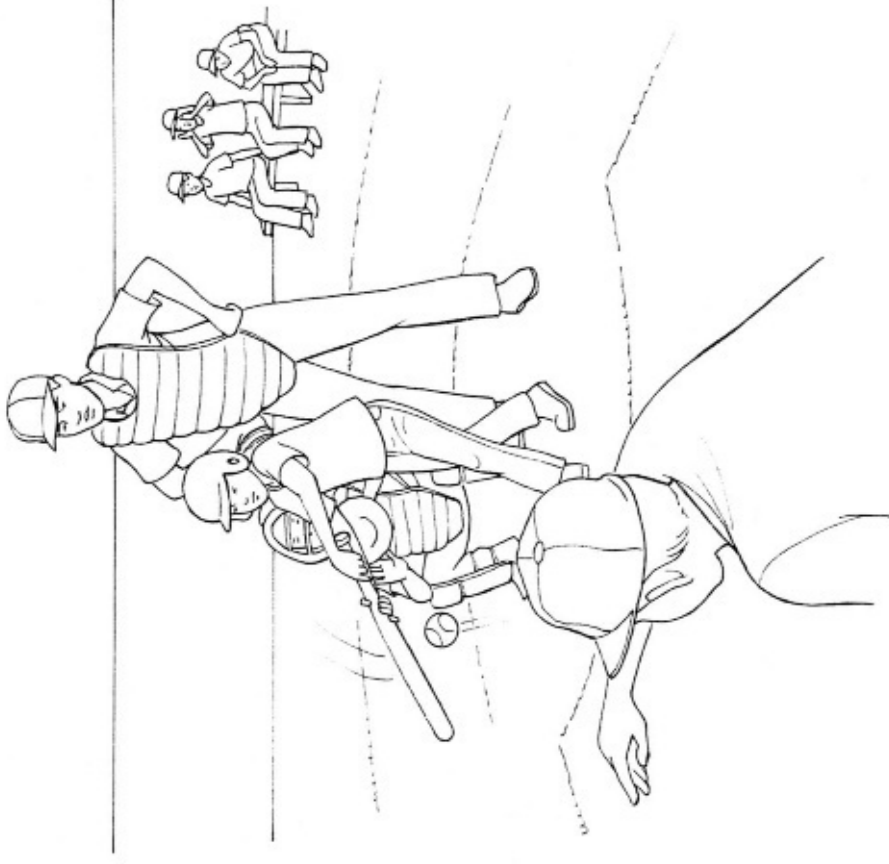

Trish can bunt.

Trish got a hit.

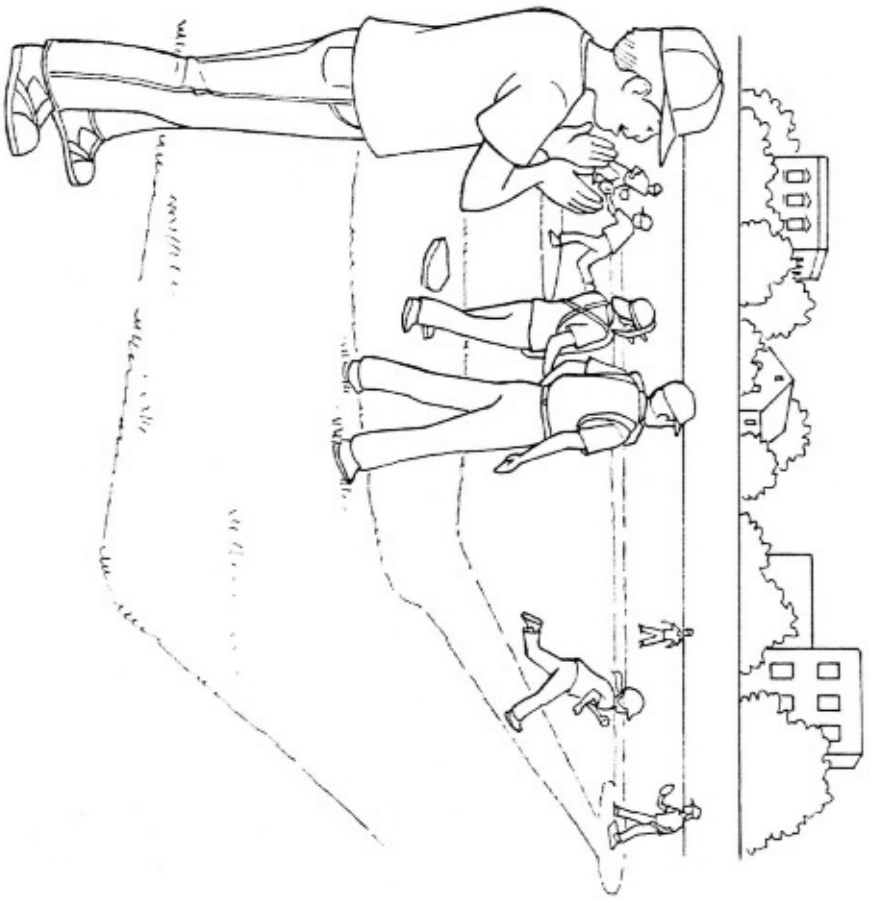

On the bench, Mitch claps. Trish runs.

8

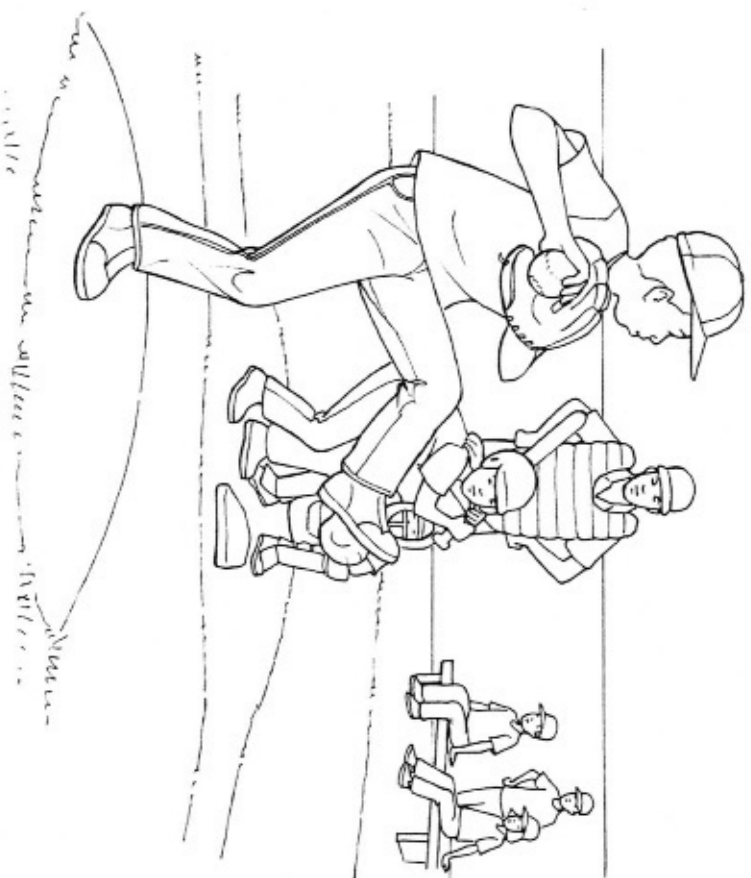

Chad can pitch.

Chad can pitch fast.

9

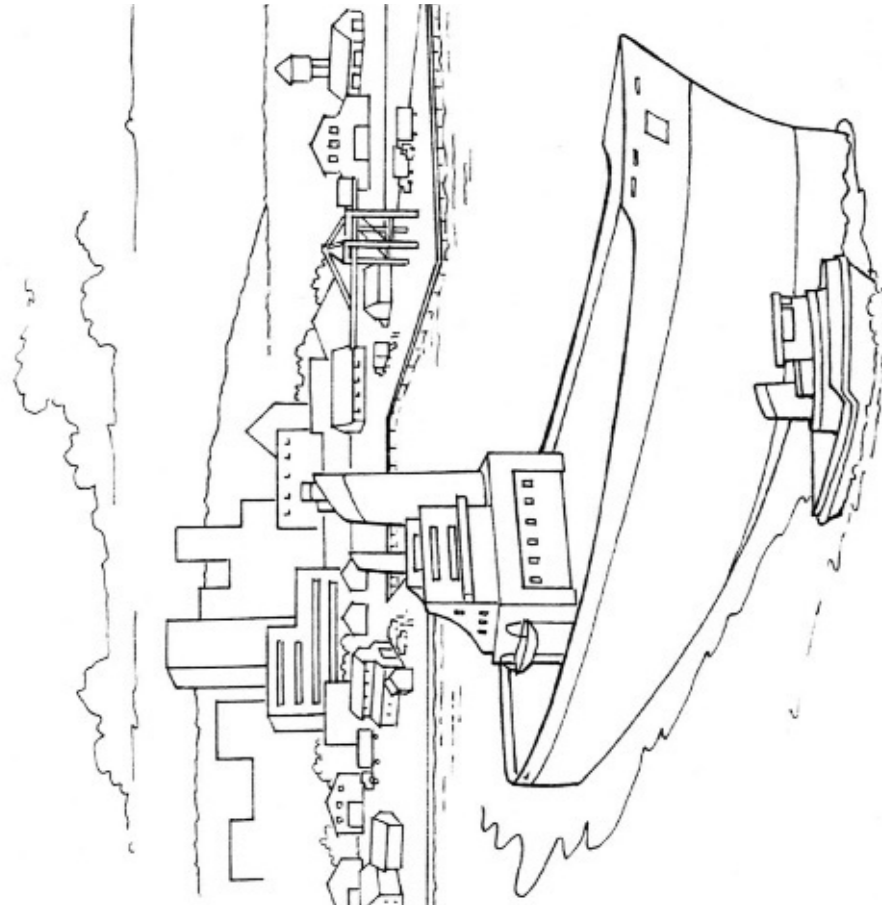

The ship sets back out.  
It heads for the next port.

# At a Port

by Alex Yu  
illustrated by Meryl Henderson

Core Decodable 44



Bothell, WA • Chicago, IL • Columbus, OH • New York, NY

MHEonline.com



Copyright © 2015 McGraw-Hill Education

All rights reserved. The contents, or parts thereof, may be reproduced in print form for non-profit educational use with *SRA Open Court Reading*, provided such reproductions bear copyright notice, but may not be reproduced in any form for any other purpose without the prior written consent of McGraw-Hill Education, including, but not limited to, network storage or transmission, or broadcast for distance learning.

Send all inquiries to:  
McGraw-Hill Education  
8787 Orion Place  
Columbus, OH 43240

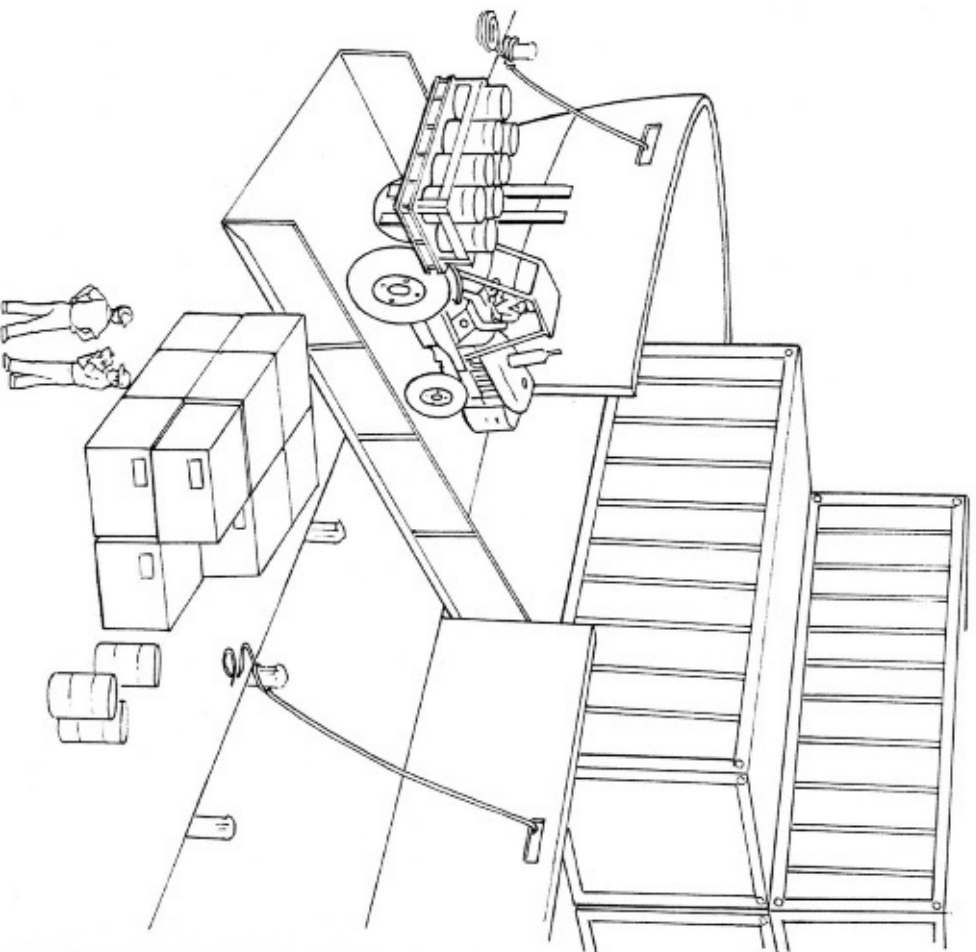

This is a forklift.  
It gets more out of the ship.



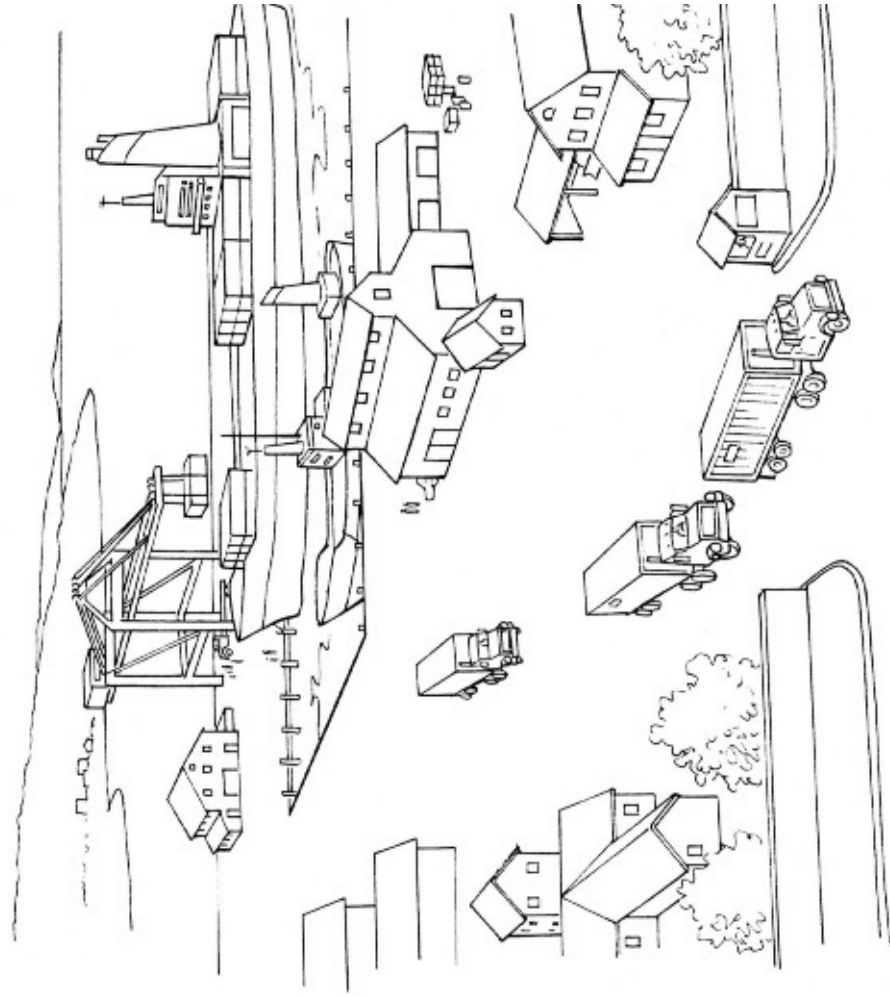

The trucks head out to stores.

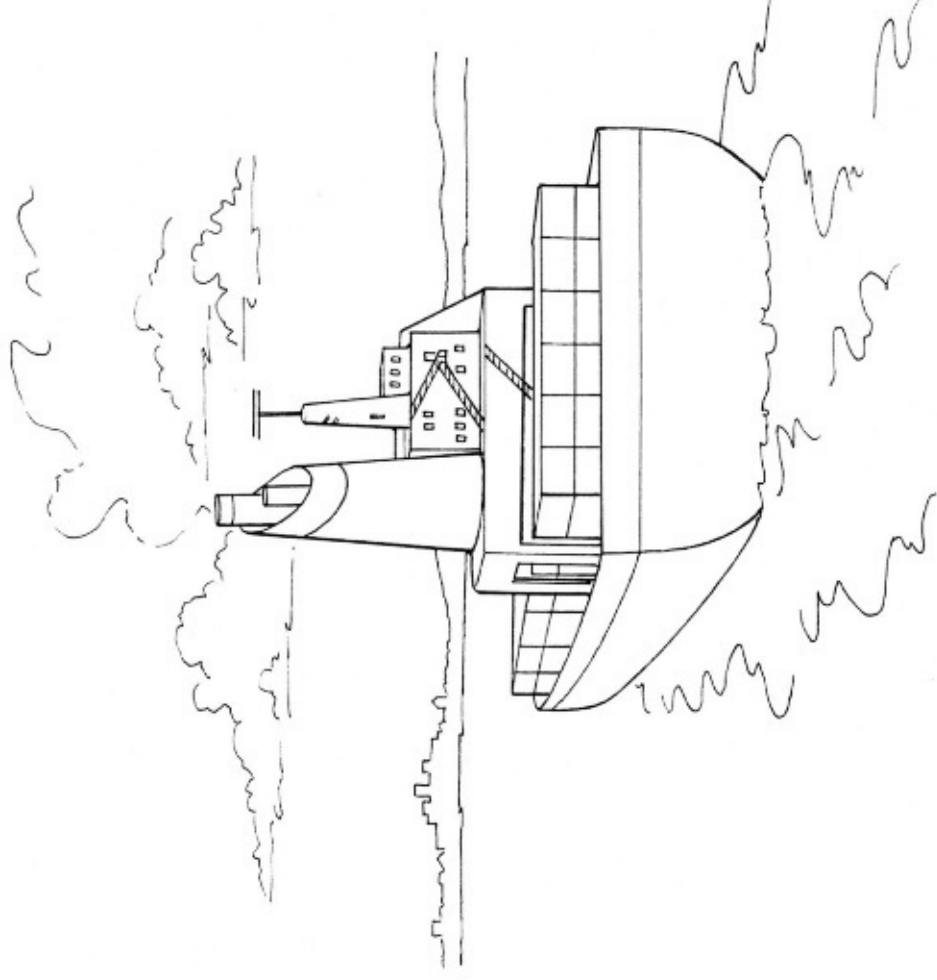

A ship heads north to shore.

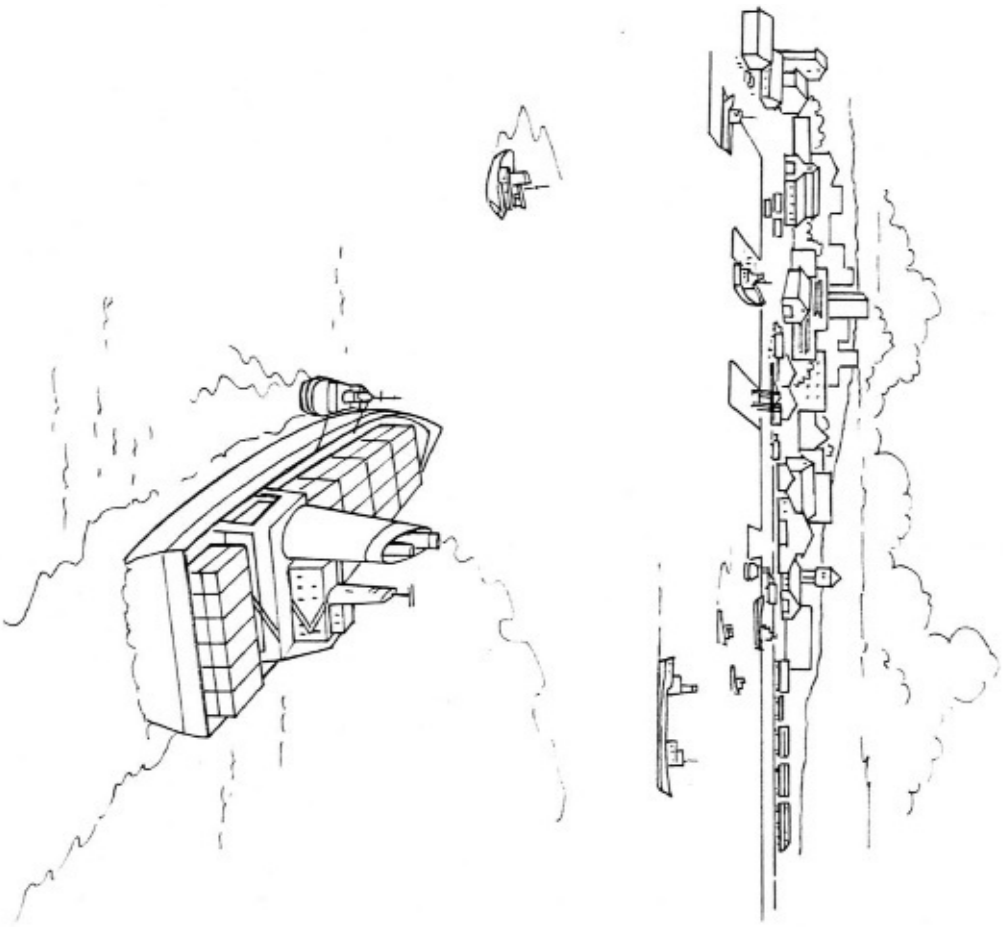

A ship blasts its horn.

It is in a port.

4

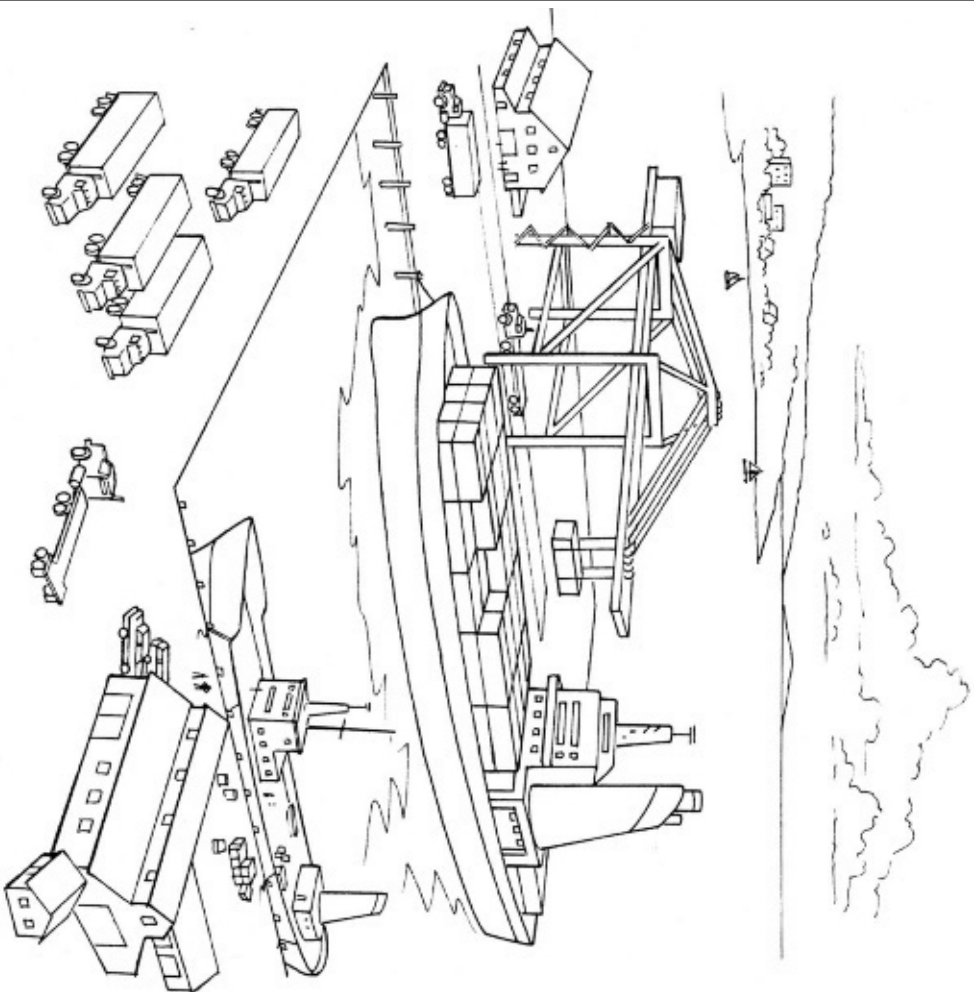

This box is for a truck.

This box is lifted out.

5

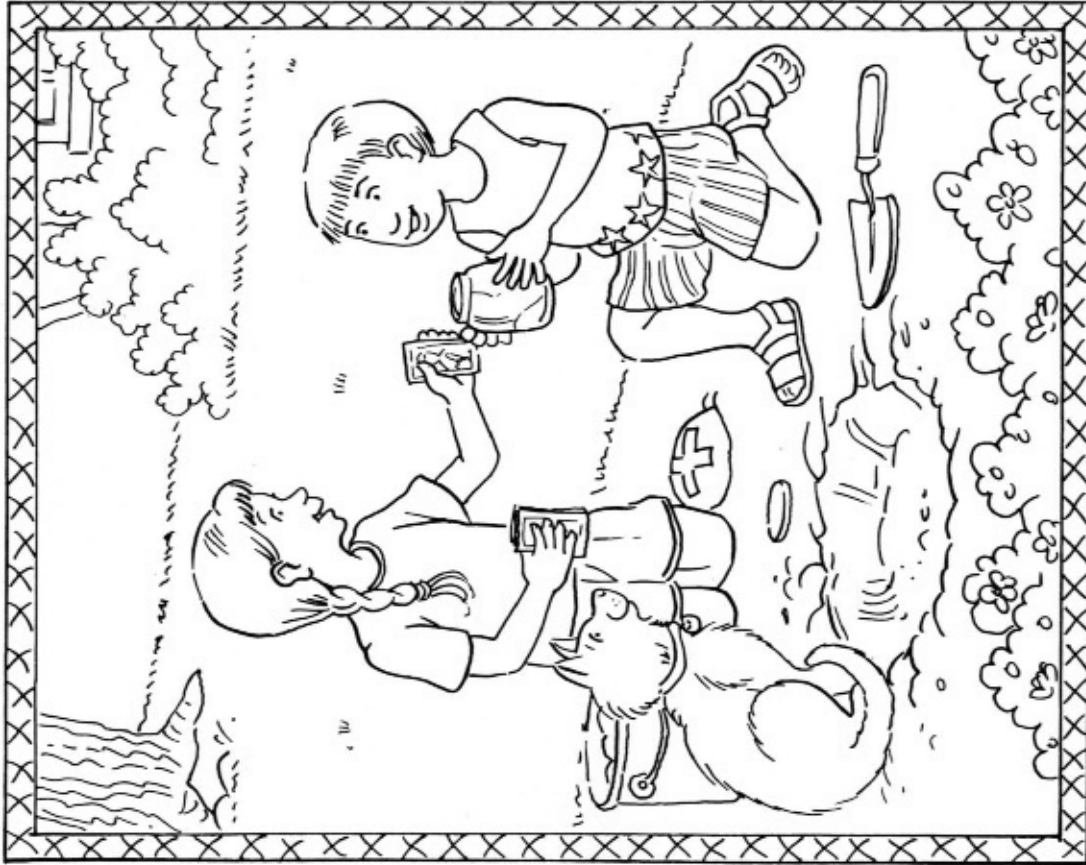

That little jar had sports cards!

# In a Jar

by Charles Broderick  
illustrated by Mary Maass

Core Decodable 45



Bothell, WA • Chicago, IL • Columbus, OH • New York, NY

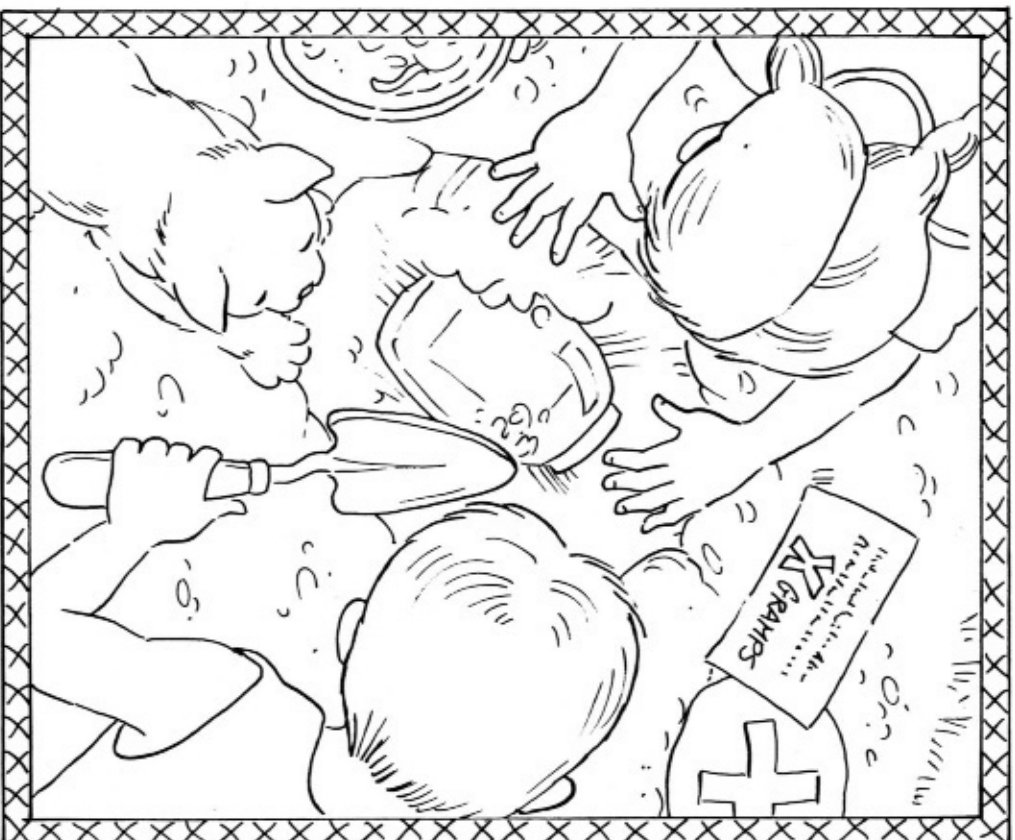

Carl dug a little more.  
Carl dug until he hit a jar.

MHEonline.com



Copyright © 2015 McGraw-Hill Education

All rights reserved. The contents, or parts thereof, may be reproduced in print form for non-profit educational use with *SRA Open Court Reading*, provided such reproductions bear copyright notice, but may not be reproduced in any form for any other purpose without the prior written consent of McGraw-Hill Education, including, but not limited to, network storage or transmission, or broadcast for distance learning.

Send all inquiries to:  
McGraw-Hill Education  
8787 Orion Place  
Columbus, OH 43240



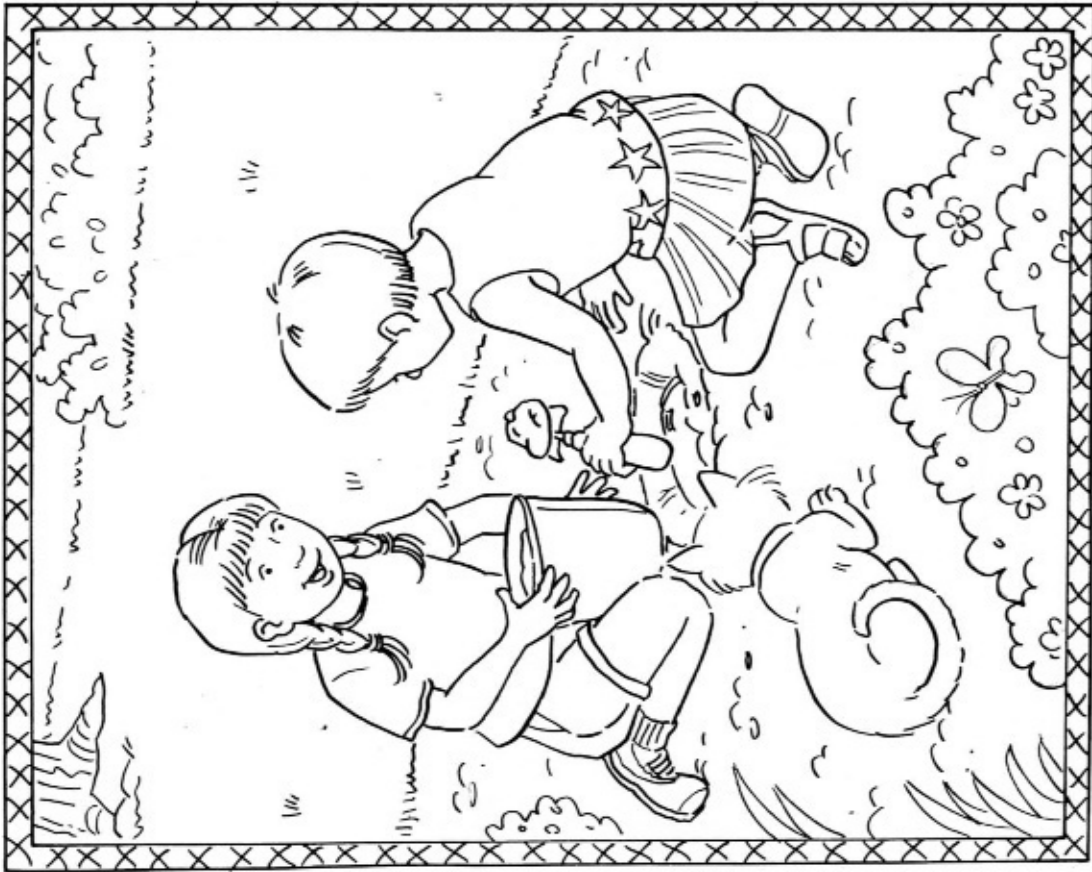

Carl started to dig in dark mud.

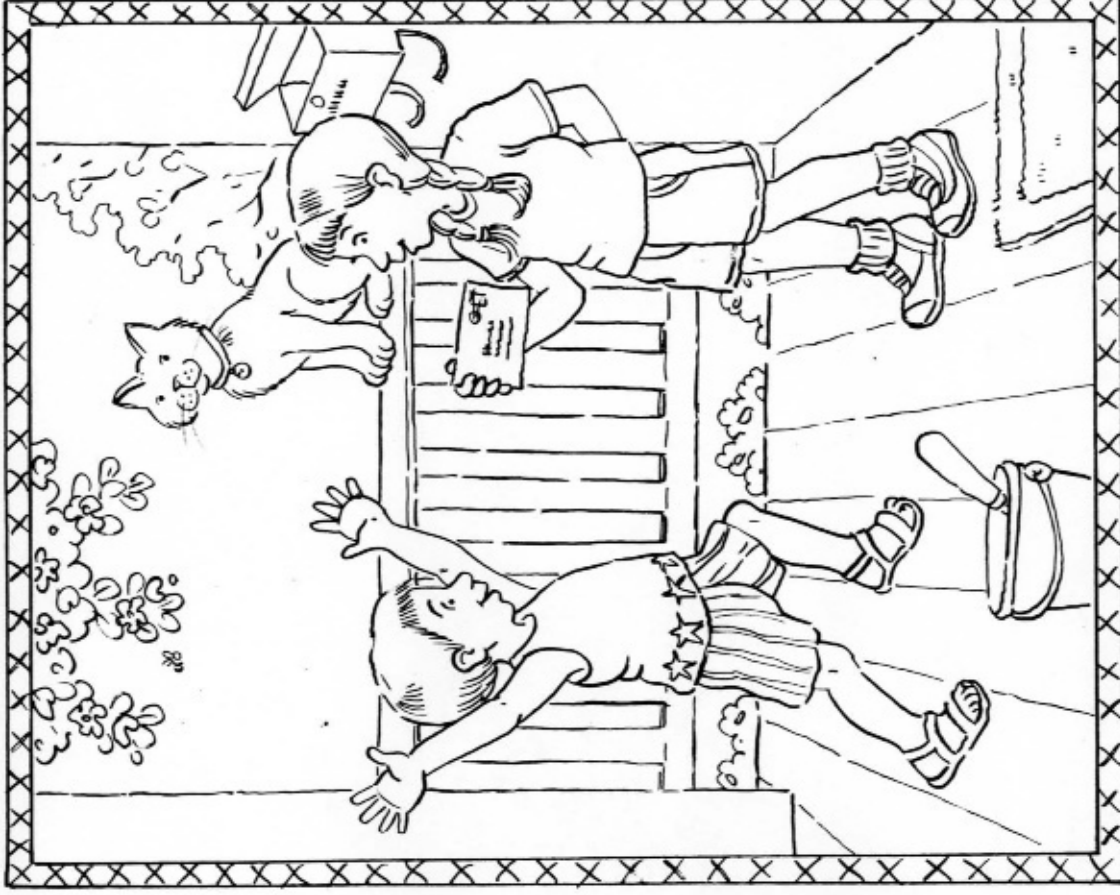

Gramps sent a little card to Carl and Barb.



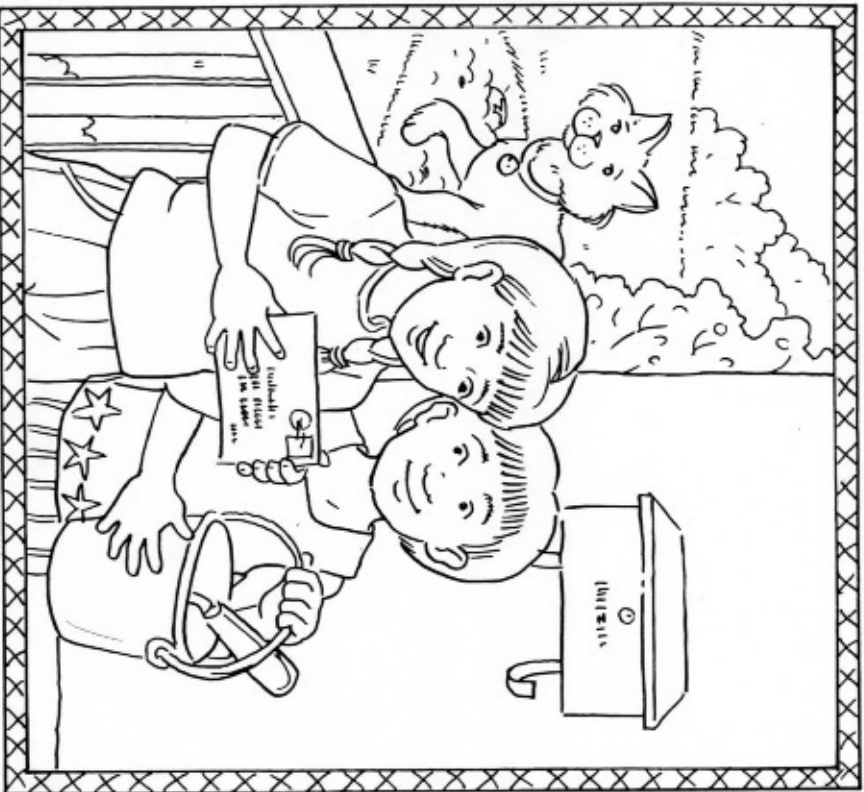

Carl and Barb read the card:  
Dig at a red mark in the garden.

Hugs,

Gramps

4



Barb spotted a little red mark.

5



The twig went. Wes is wet, and Gwen is wet!

# Wes Gets Wet

by Emma Green  
illustrated by Len Epstein

Core Decodable 46



Bothell, WA • Chicago, IL • Columbus, OH • New York, NY

MHEonline.com



Copyright © 2015 McGraw-Hill Education

All rights reserved. The contents, or parts thereof, may be reproduced in print form for non-profit educational use with *SRA Open Court Reading*, provided such reproductions bear copyright notice, but may not be reproduced in any form for any other purpose without the prior written consent of McGraw-Hill Education, including, but not limited to, network storage or transmission, or broadcast for distance learning.

Send all inquiries to:  
 McGraw-Hill Education  
 8787 Orion Place  
 Columbus, OH 43240

2



The wind grabs a twig.  
 Wes jumps and runs. Wes is swift!

7

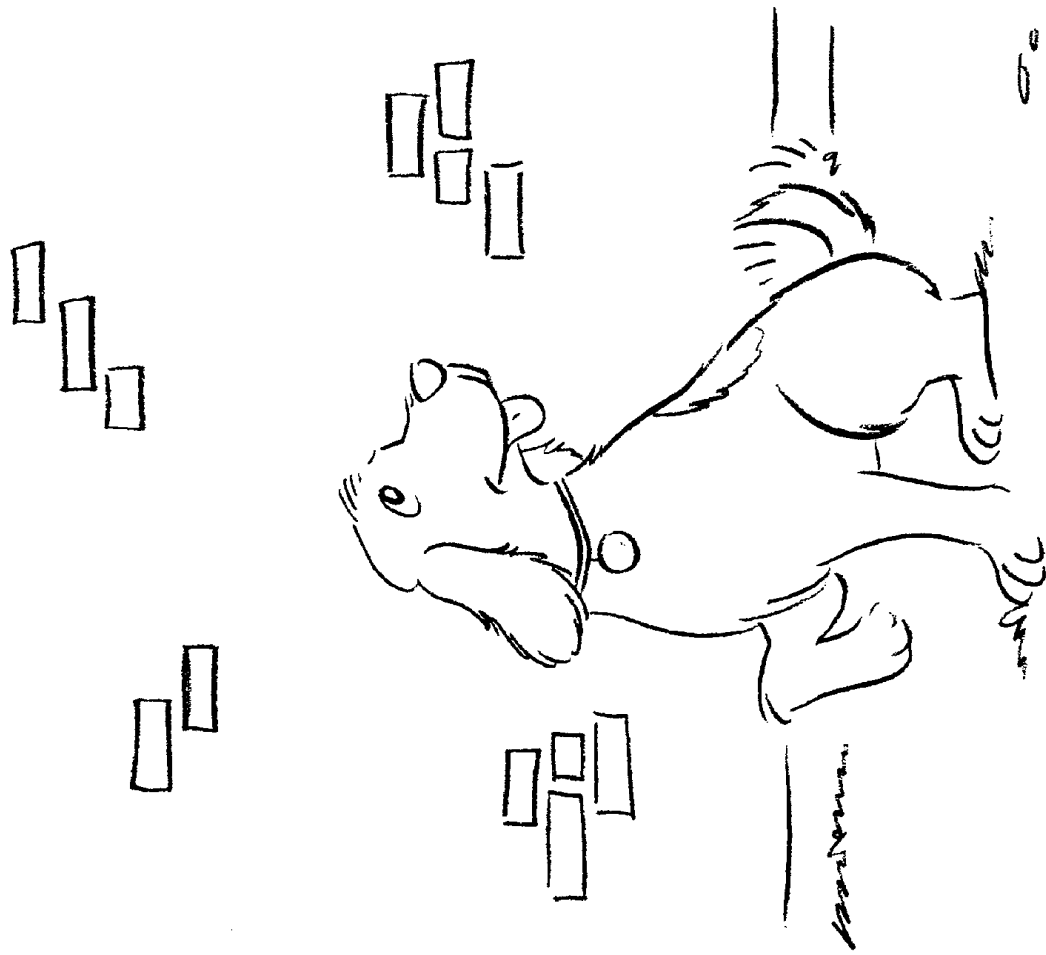

Wes sits and sits.

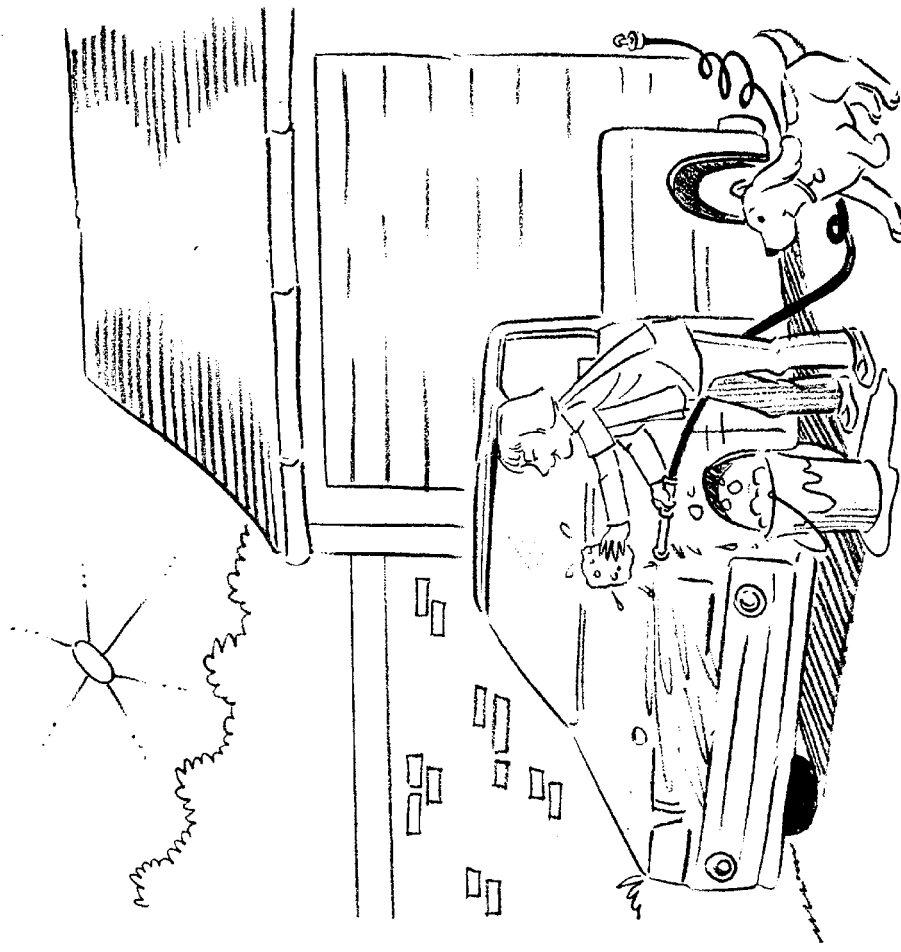

Gwen scrubs Dad's truck.

Wes trots to help.

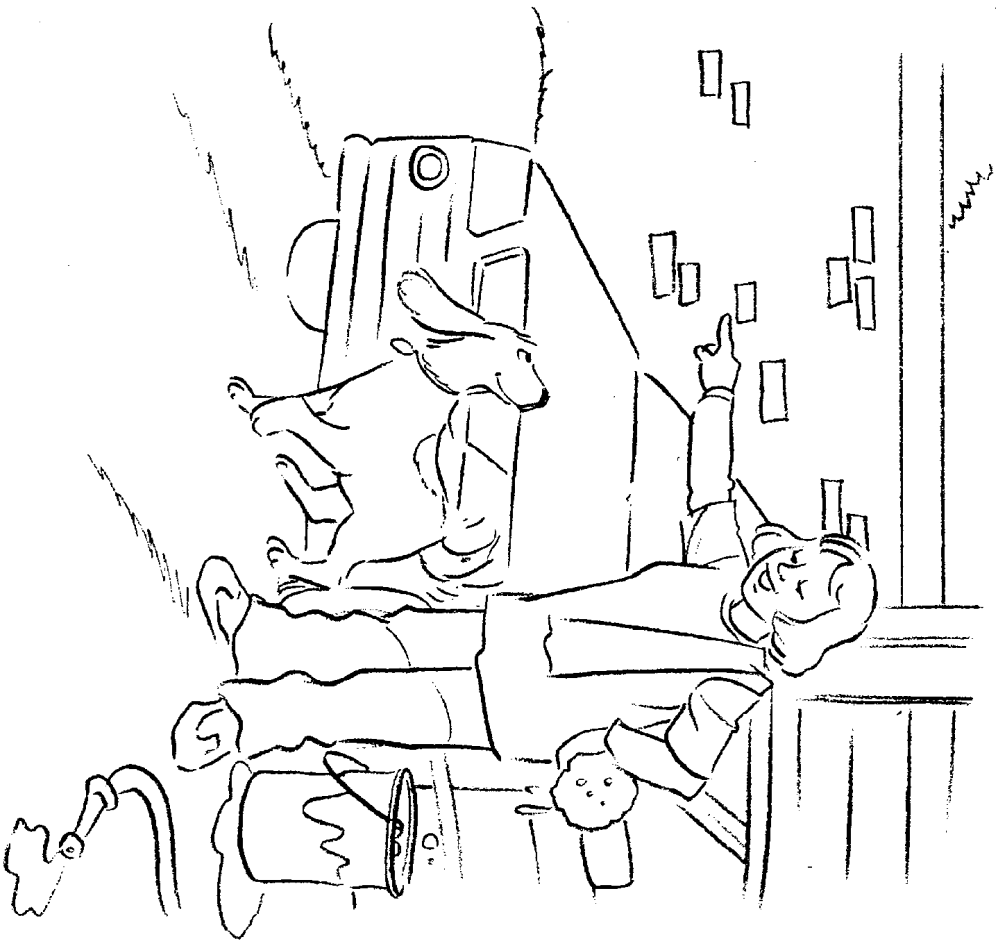

Gwen tells Wes to sit next to the wall.

Will Wes get wet there?

4

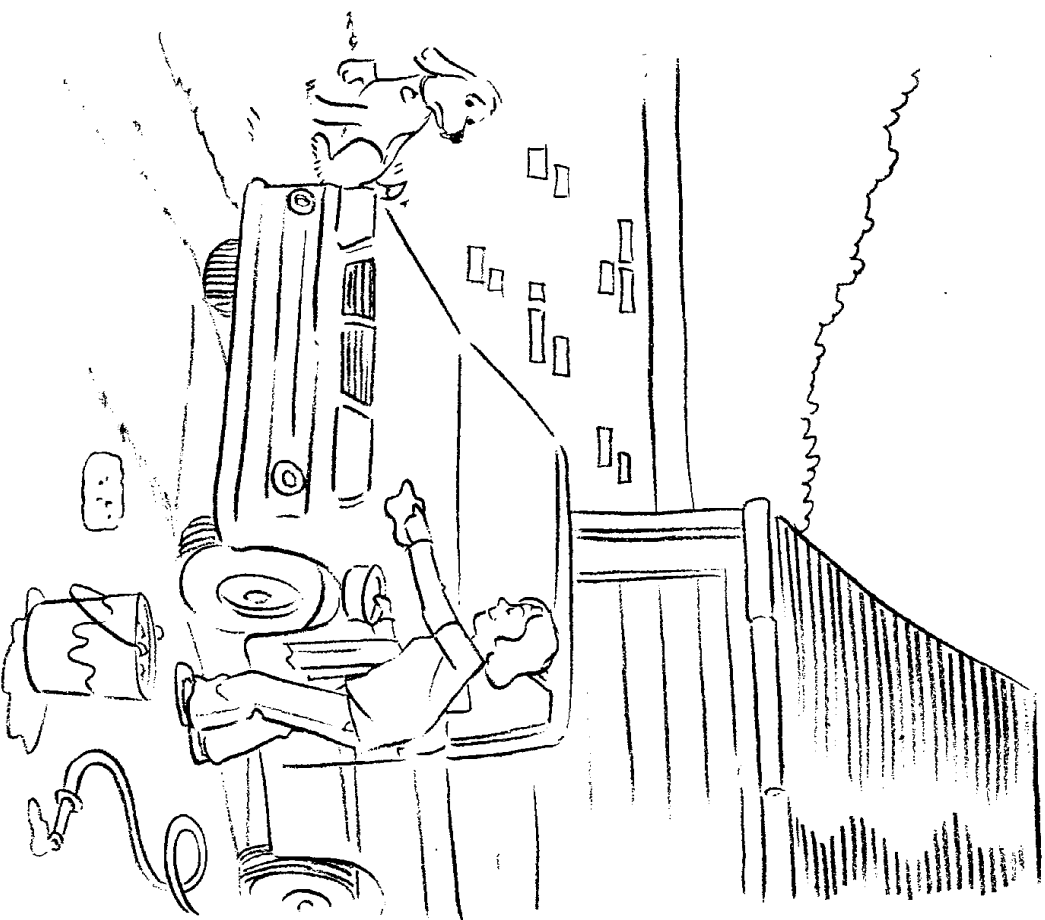

Gwen waxes the truck.

Wes sits and twitches.

5



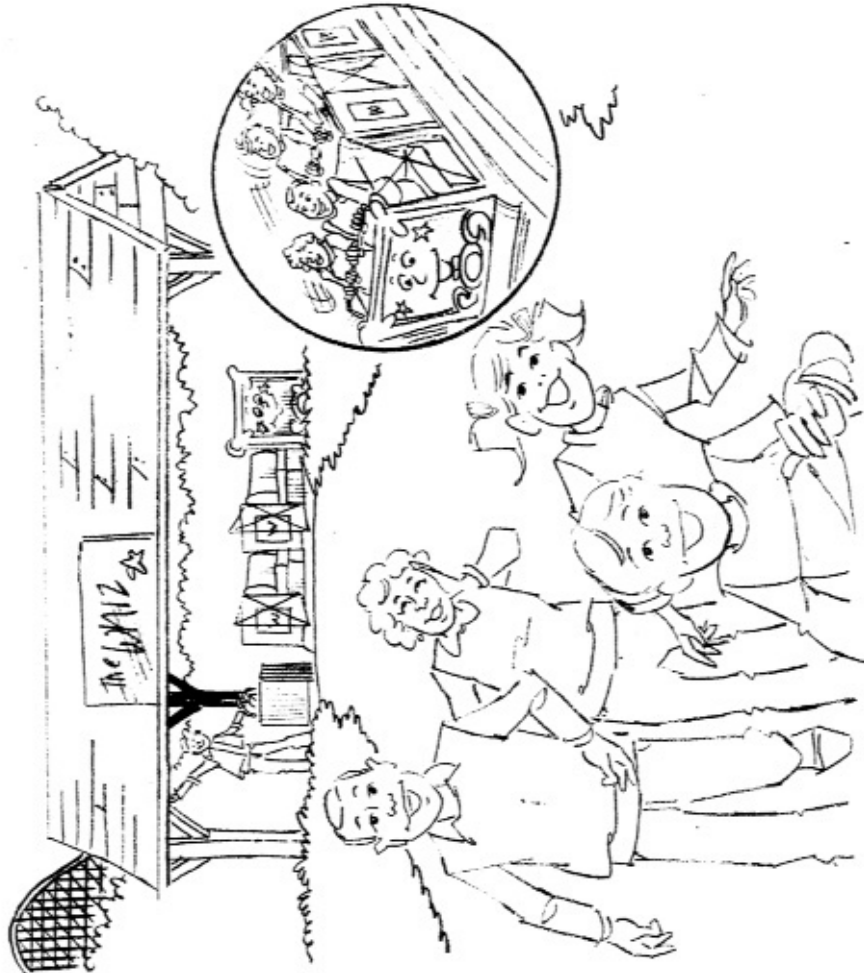

Wham! When the Whiz stops, it stops fast.

# The Whiz

by Mark Decker  
illustrated by Len Epstein

Core Decodable 47



Bothell, WA • Chicago, IL • Columbus, OH • New York, NY

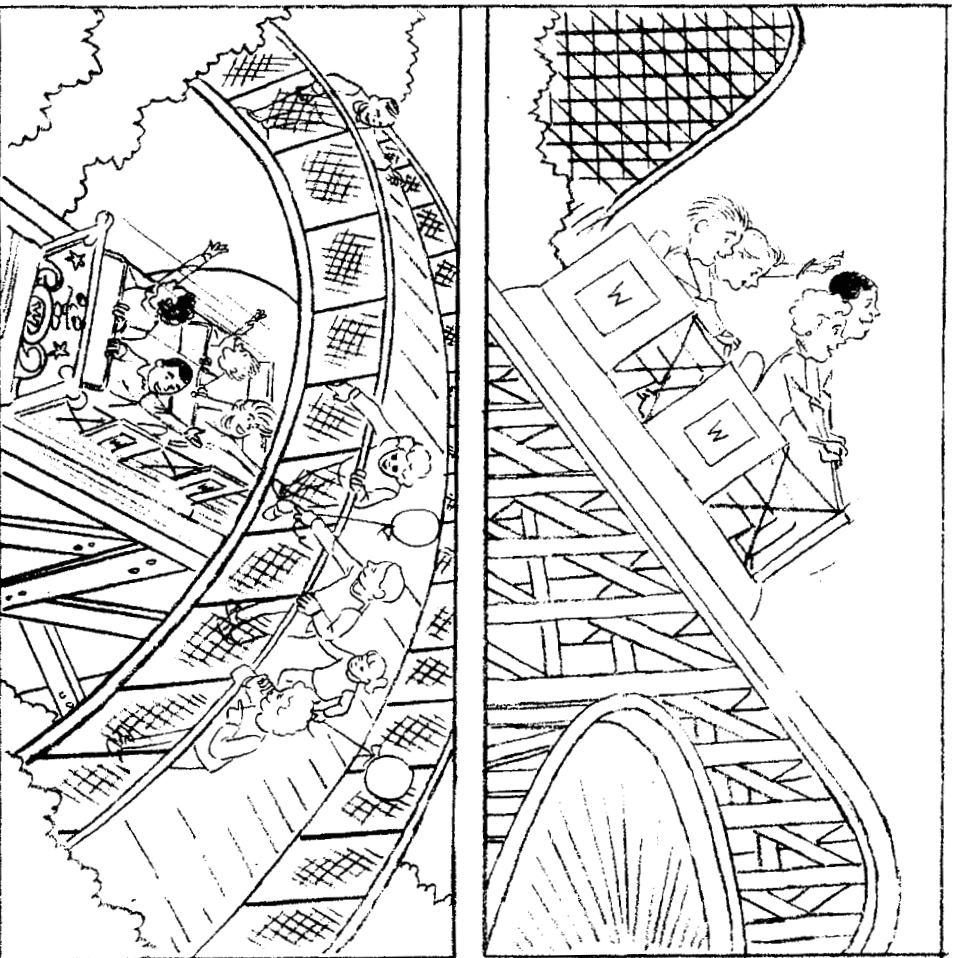

The Whiz whips up a big hill.  
Then it whips past a bridge.

MHEonline.com



Copyright © 2015 McGraw-Hill Education

All rights reserved. The contents, or parts thereof, may be reproduced in print form for non-profit educational use with *SRA Open Court Reading*, provided such reproductions bear copyright notice, but may not be reproduced in any form for any other purpose without the prior written consent of McGraw-Hill Education, including, but not limited to, network storage or transmission, or broadcast for distance learning.

Send all inquiries to:  
McGraw-Hill Education  
8787 Orion Place  
Columbus, OH 43240

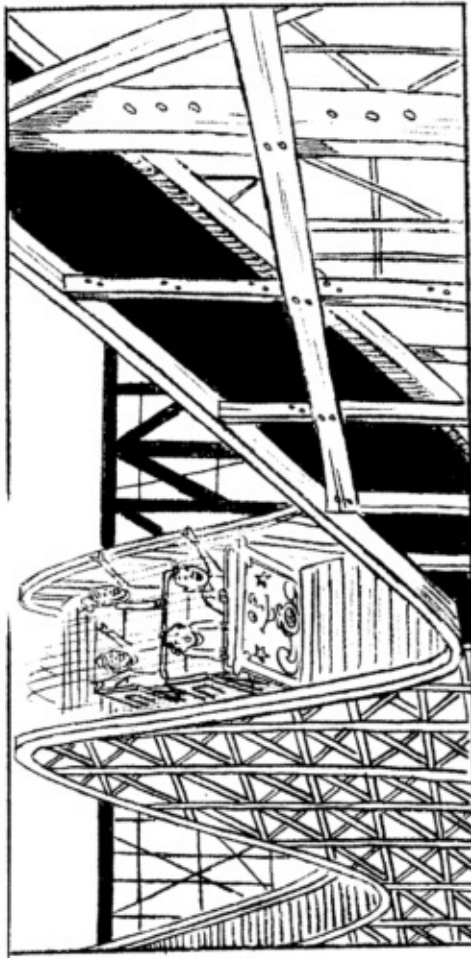

Wham! The Whiz whips left.

Wham! The Whiz whips back.

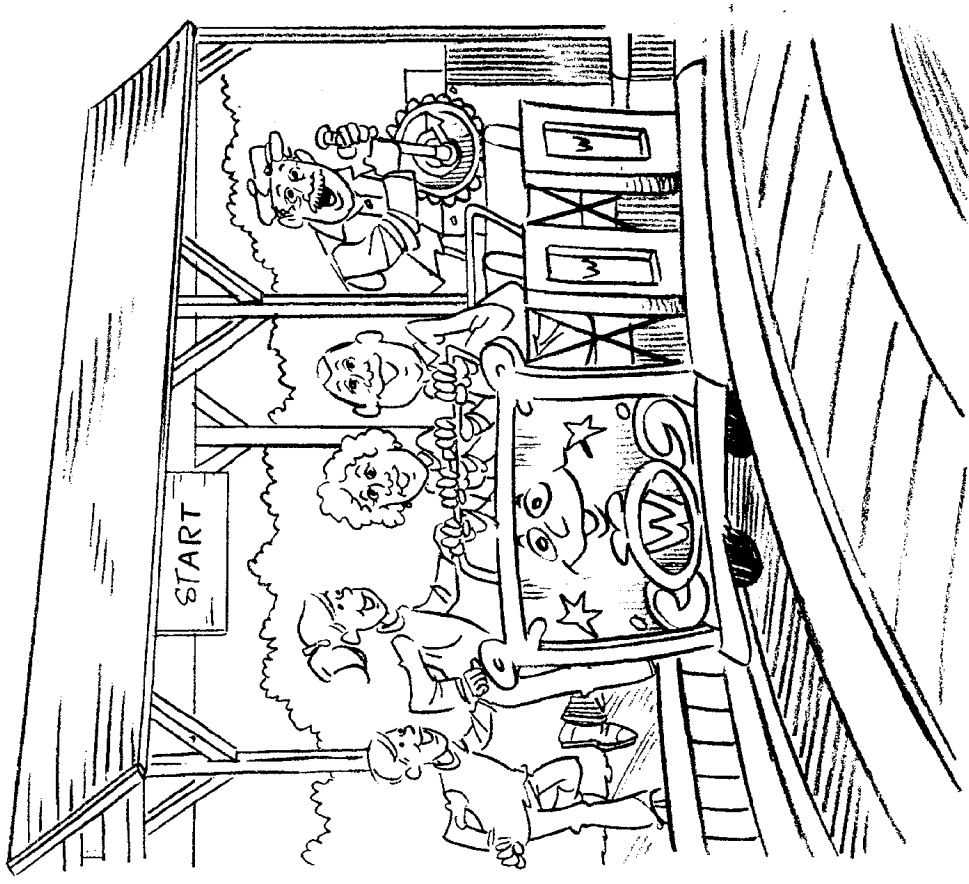

This is the Whiz.



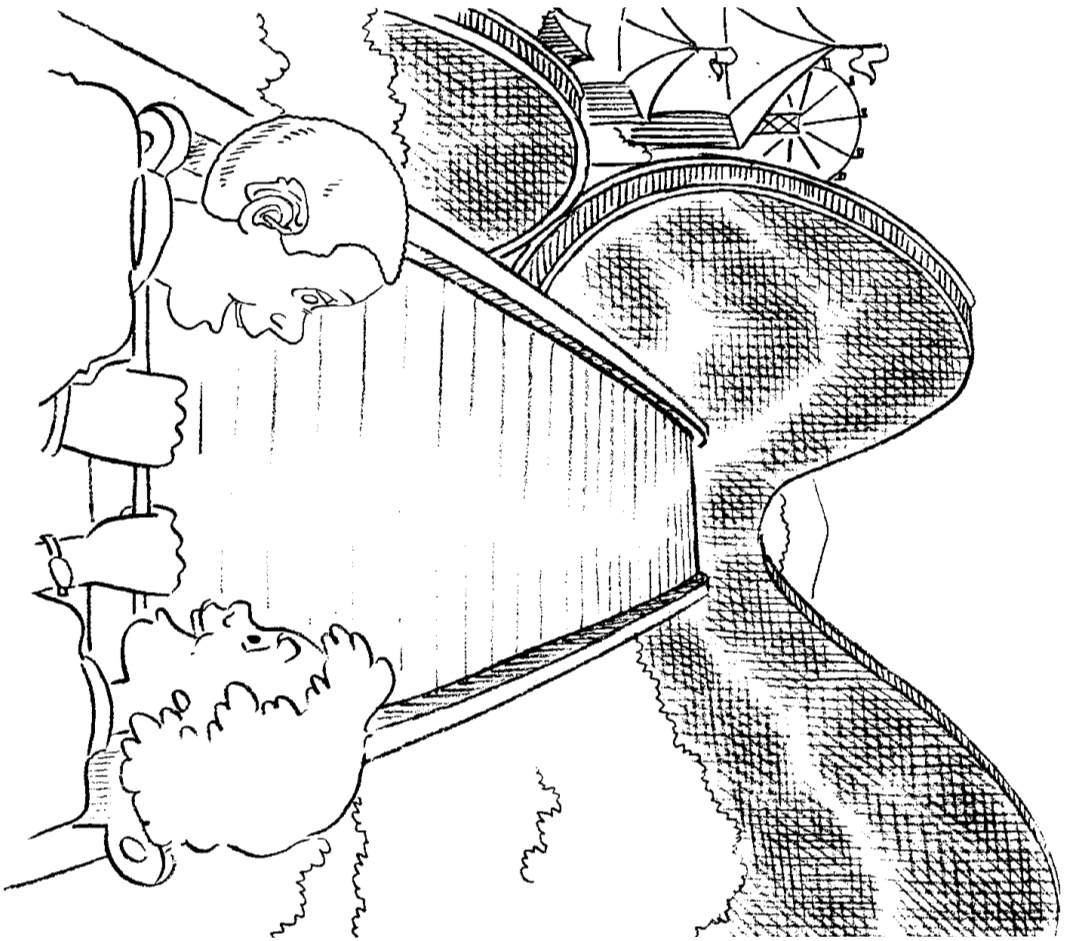

When the Whiz starts, it chugs up and up.

4

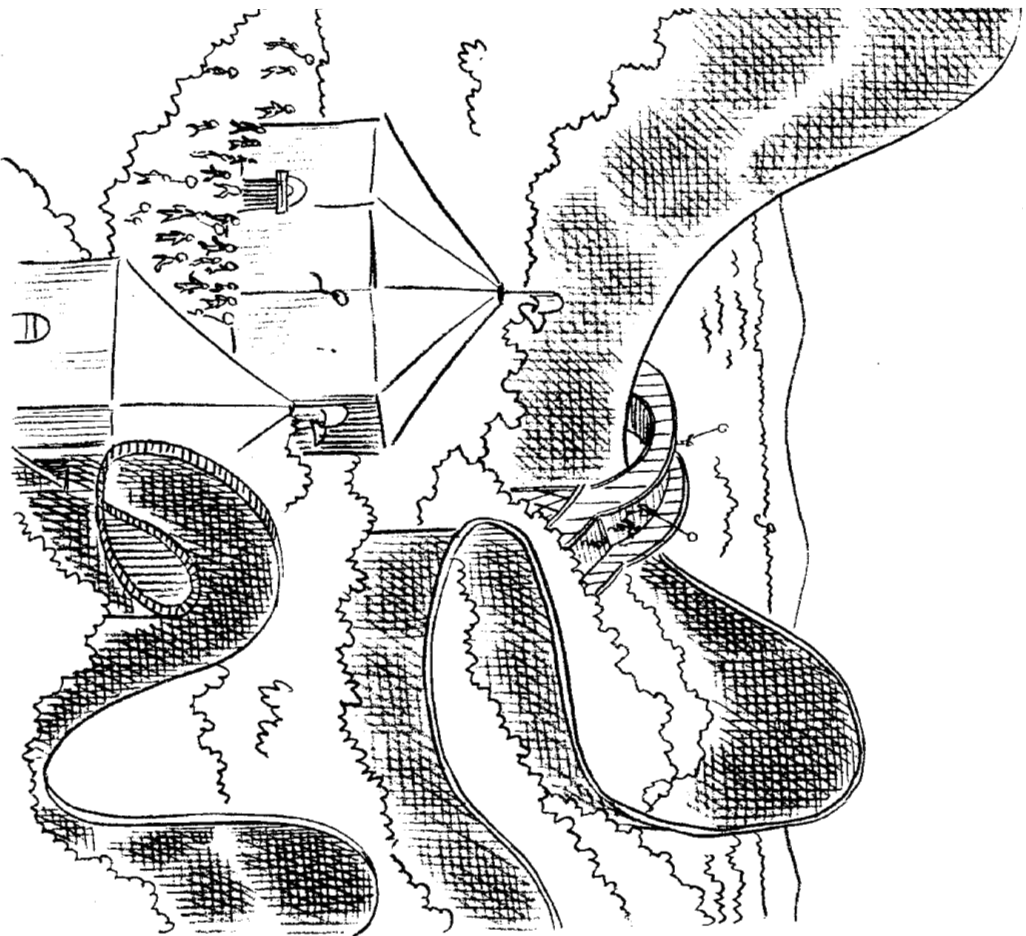

When it is at the top, the Whiz stops.

5

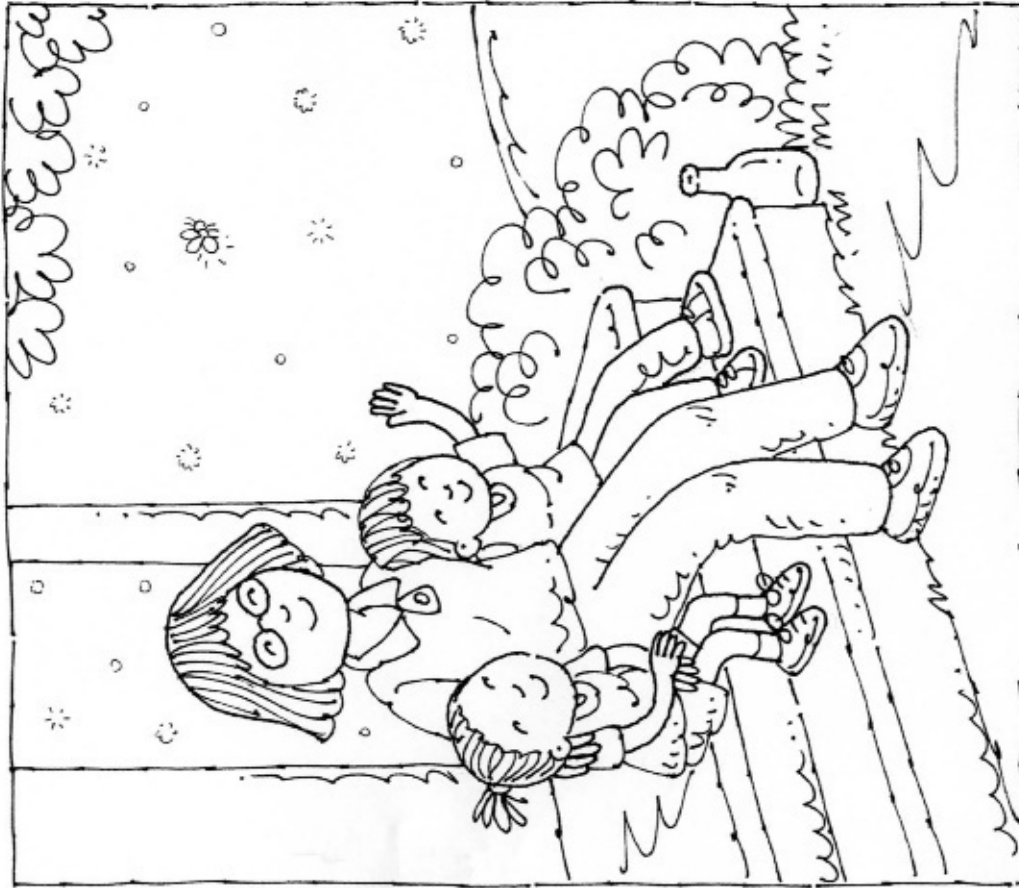

“A spark in the dark,” said Carmen.

# A Spark in the Dark

by Thomas Sato  
illustrated by Benton Mahan

Core Decodable 48



Bothell, WA • Chicago, IL • Columbus, OH • New York, NY





“That is a bug,” said Corbin.  
“I will catch more in a jar.”

MHEonline.com



Copyright © 2015 McGraw-Hill Education

All rights reserved. The contents, or parts thereof, may be reproduced in print form for non-profit educational use with *SRA Open Court Reading*, provided such reproductions bear copyright notice, but may not be reproduced in any form for any other purpose without the prior written consent of McGraw-Hill Education, including, but not limited to, network storage or transmission, or broadcast for distance learning.

Send all inquiries to:  
McGraw-Hill Education  
8787 Orion Place  
Columbus, OH 43240

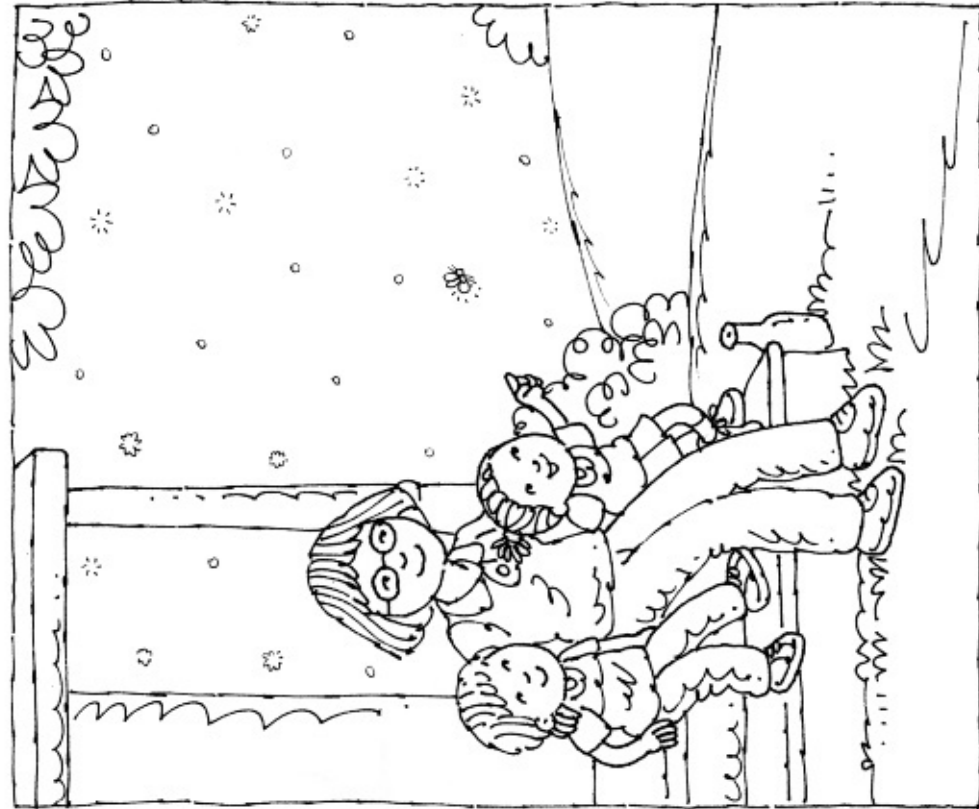

“What a star!” said Carmen.  
 “I wish I had that star.”

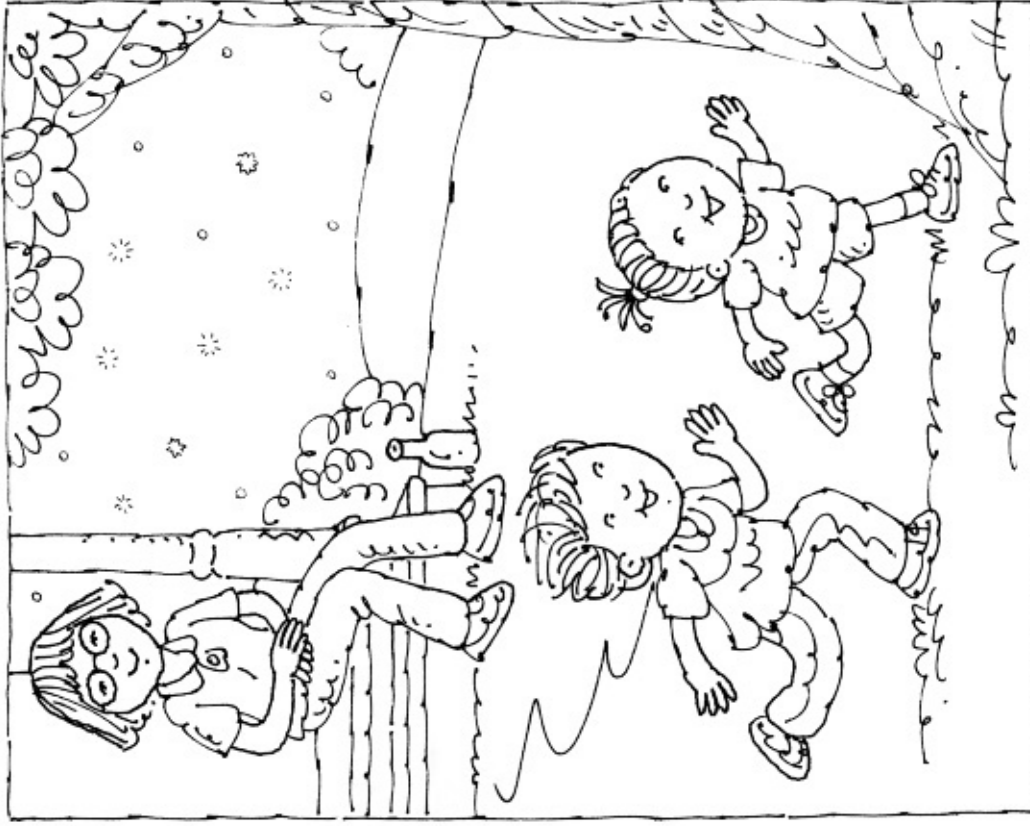

Mom sits on the porch.  
 The twins whiz past.

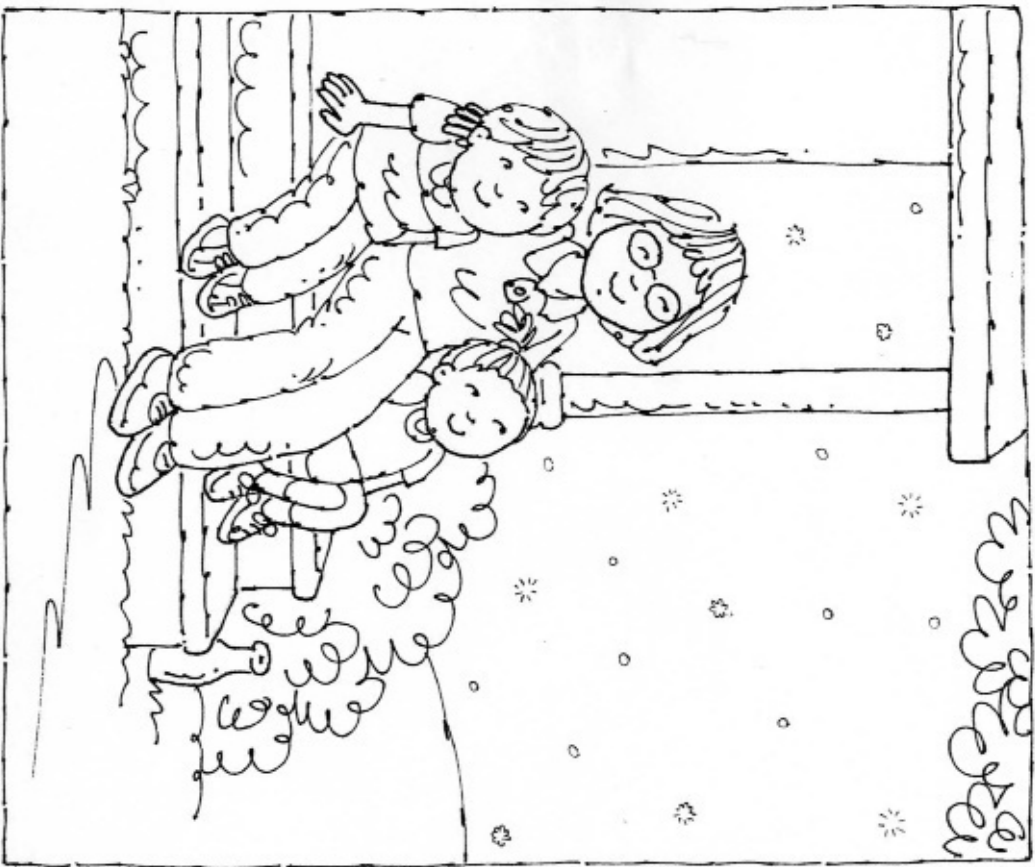

When it is dark, the stars are out.

4

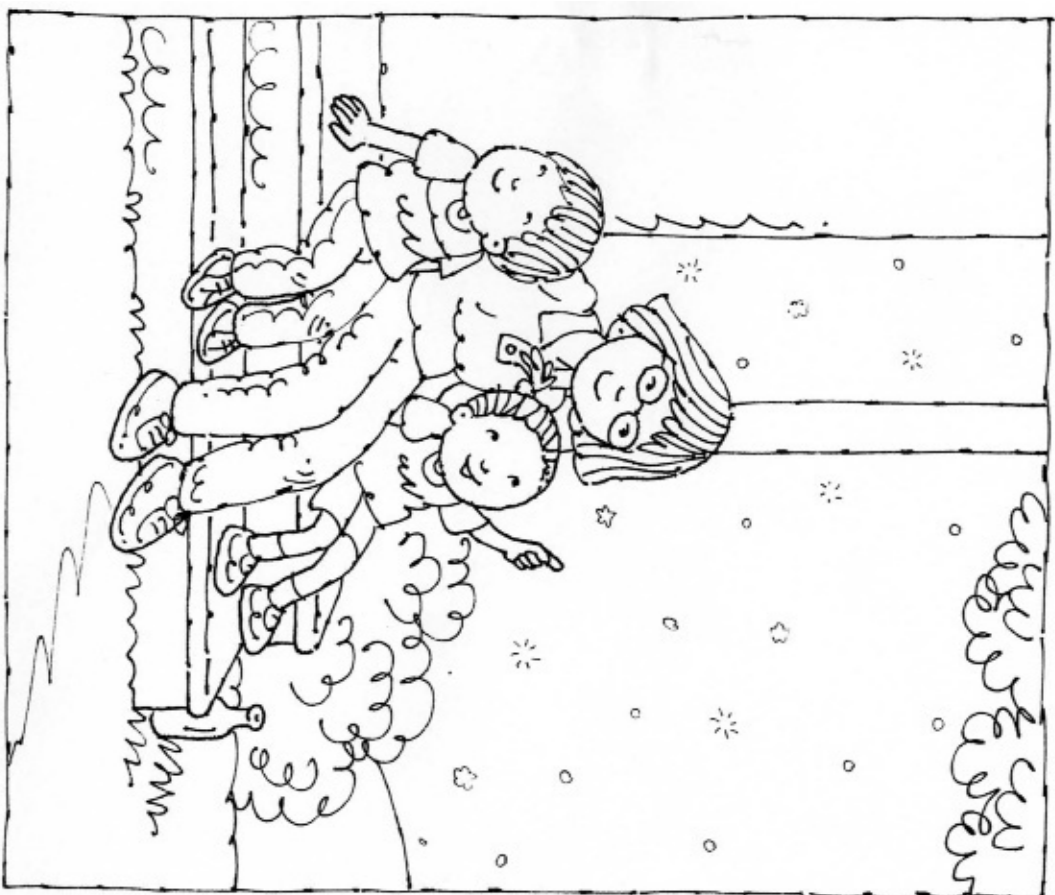

Carmen spots a little star.

It is not far up.

5



As a matter of fact, there was!

# Bird Shirts

by Trisha Roberts  
illustrated by Kersti Frigell

Core Decodable 49



Bothell, WA • Chicago, IL • Columbus, OH • New York, NY



MHEonline.com



Copyright © 2015 McGraw-Hill Education

All rights reserved. The contents, or parts thereof, may be reproduced in print form for non-profit educational use with *SRA Open Court Reading*, provided such reproductions bear copyright notice, but may not be reproduced in any form for any other purpose without the prior written consent of McGraw-Hill Education, including, but not limited to, network storage or transmission, or broadcast for distance learning.

Send all inquiries to:  
McGraw-Hill Education  
8787 Orion Place  
Columbus, OH 43240

2



Amber's last gift was a shirt.  
Was there a bird on it?

7





Amber's third gift was a skirt.

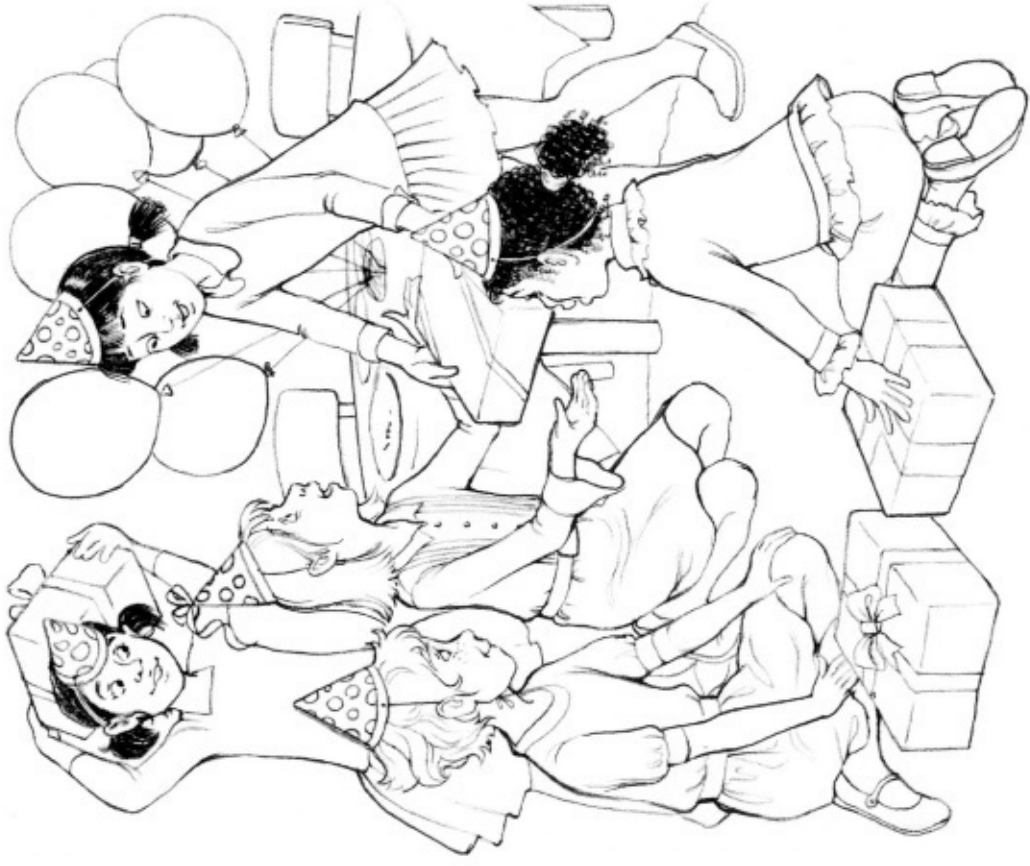

The girls had gifts for Amber.



Her first gift was a shirt.  
The shirt had a bird on it.

4



Amber's next gift was a shirt.  
It had a bigger bird on it!

5

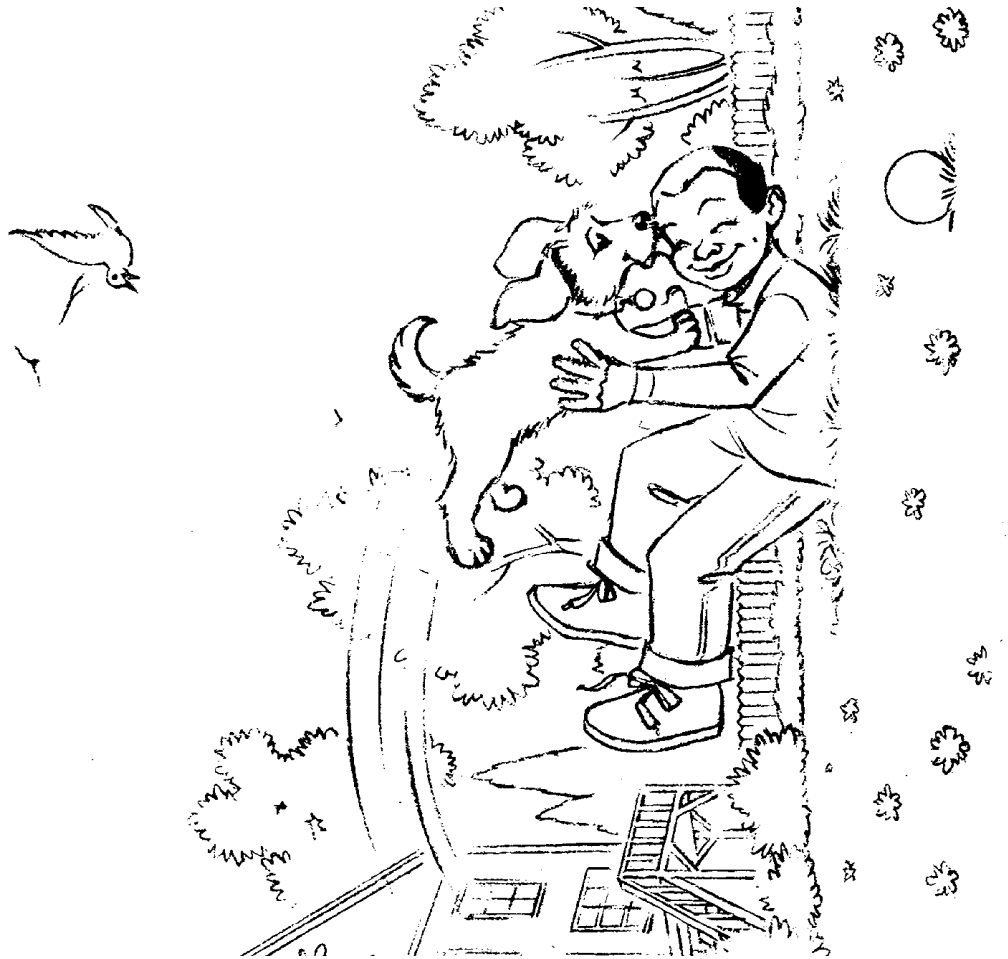

It is Burt!  
The blur with fur is Burt.

# A Blur with Fur

by Chris Mathews  
illustrated by Mark Corcoran

Core Decodable 50



Bothell, WA • Chicago, IL • Columbus, OH • New York, NY



MHEonline.com



Copyright © 2015 McGraw-Hill Education

All rights reserved. The contents, or parts thereof, may be reproduced in print form for non-profit educational use with *SRA Open Court Reading*, provided such reproductions bear copyright notice, but may not be reproduced in any form for any other purpose without the prior written consent of McGraw-Hill Education, including, but not limited to, network storage or transmission, or broadcast for distance learning.

Send all inquiries to:  
McGraw-Hill Education  
8787 Orion Place  
Columbus, OH 43240

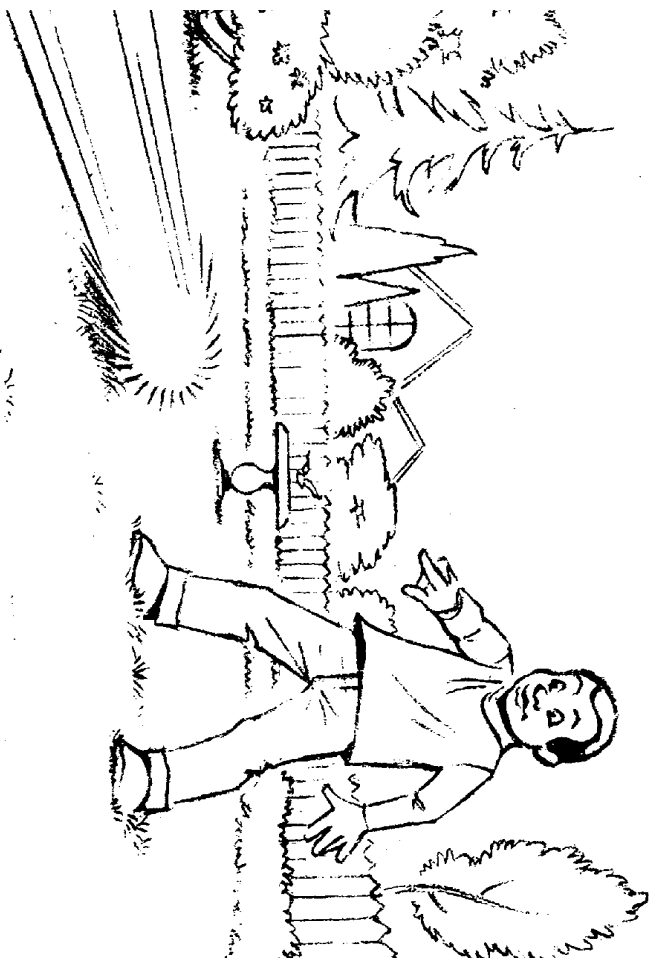

What is that blur with fur?

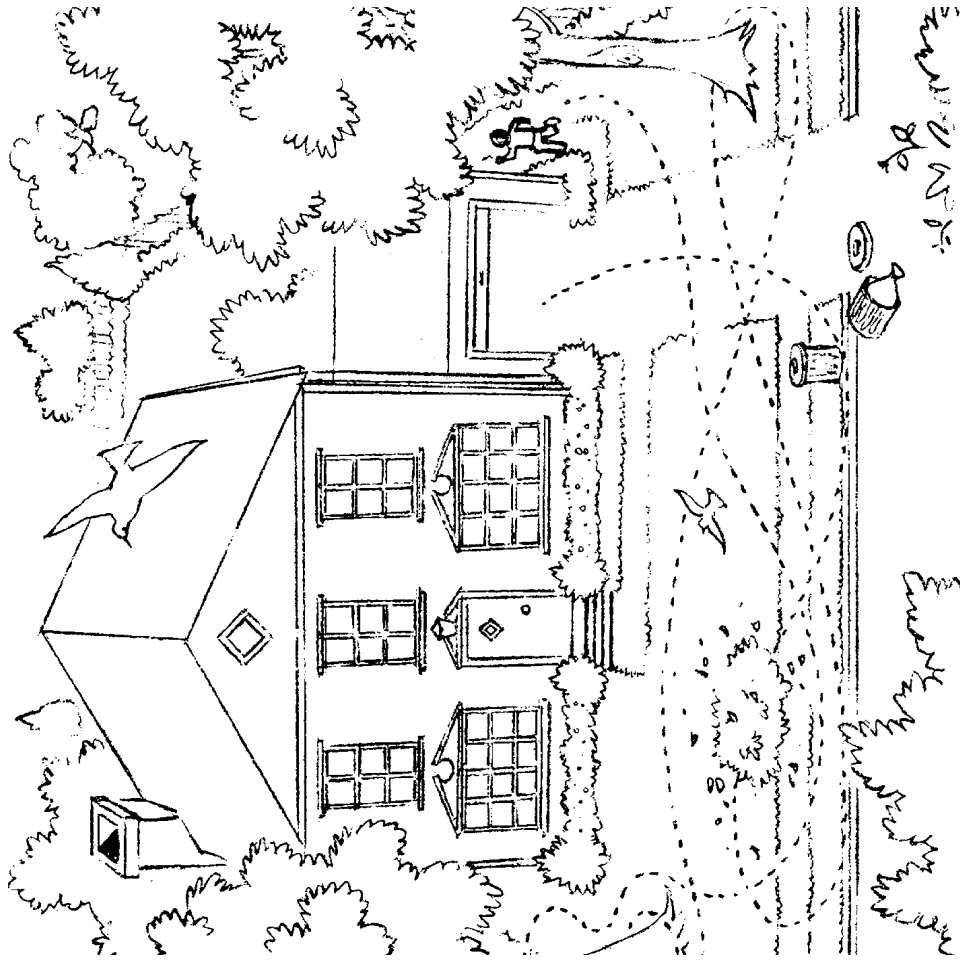

The blur with fur dashed and crashed.  
 It curled and twirled.

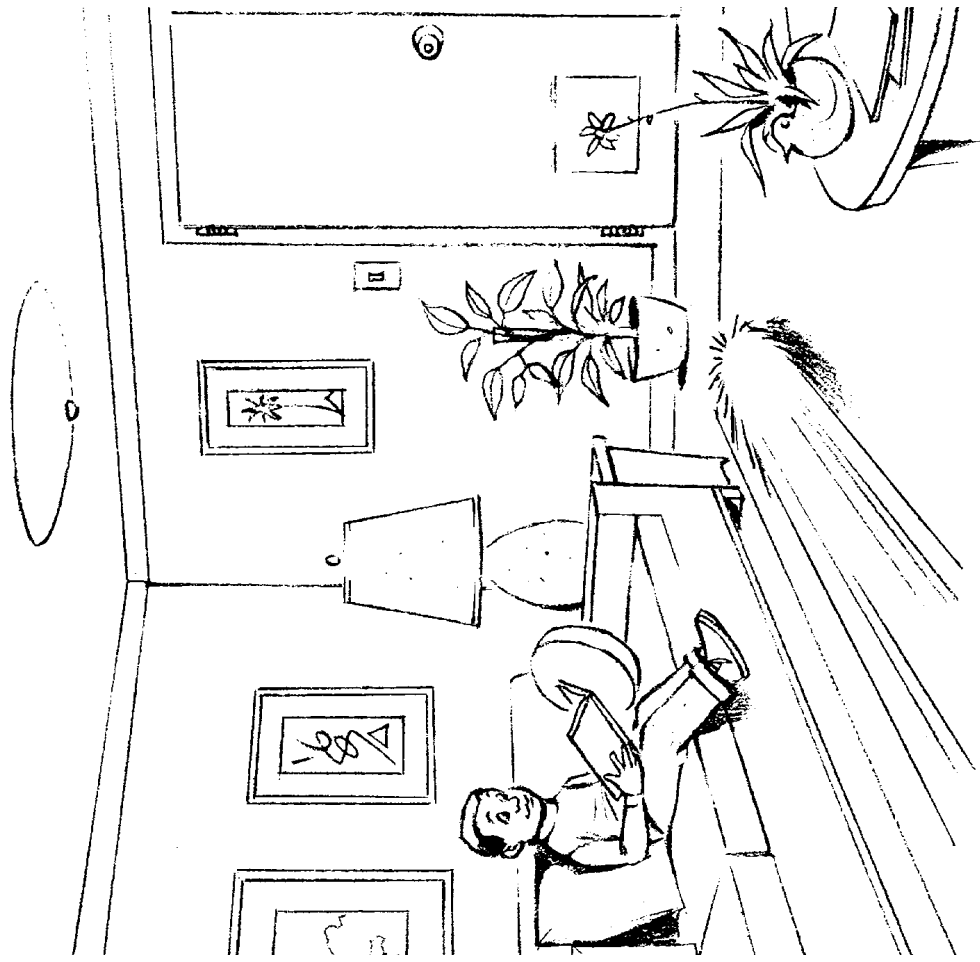

A blur with fur crossed the carpet.



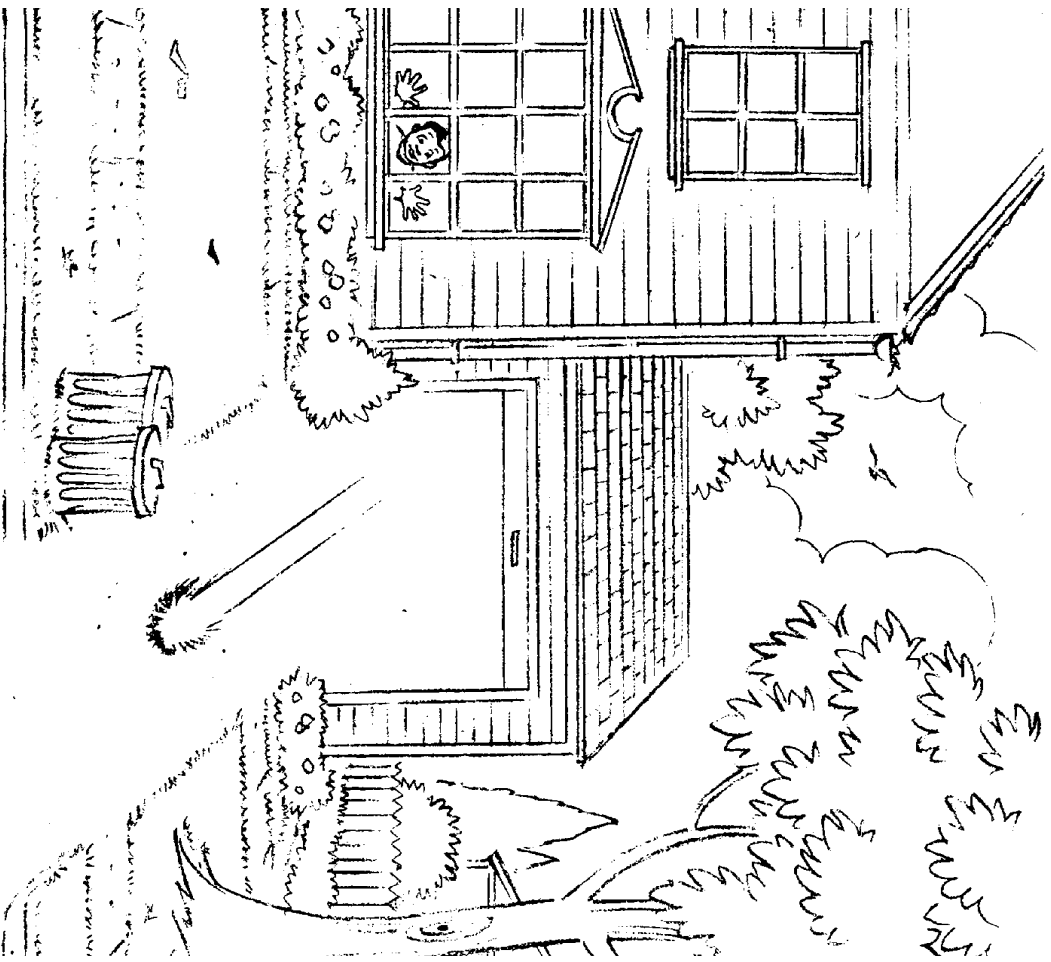

A blur with fur ran and crossed the curb.

4

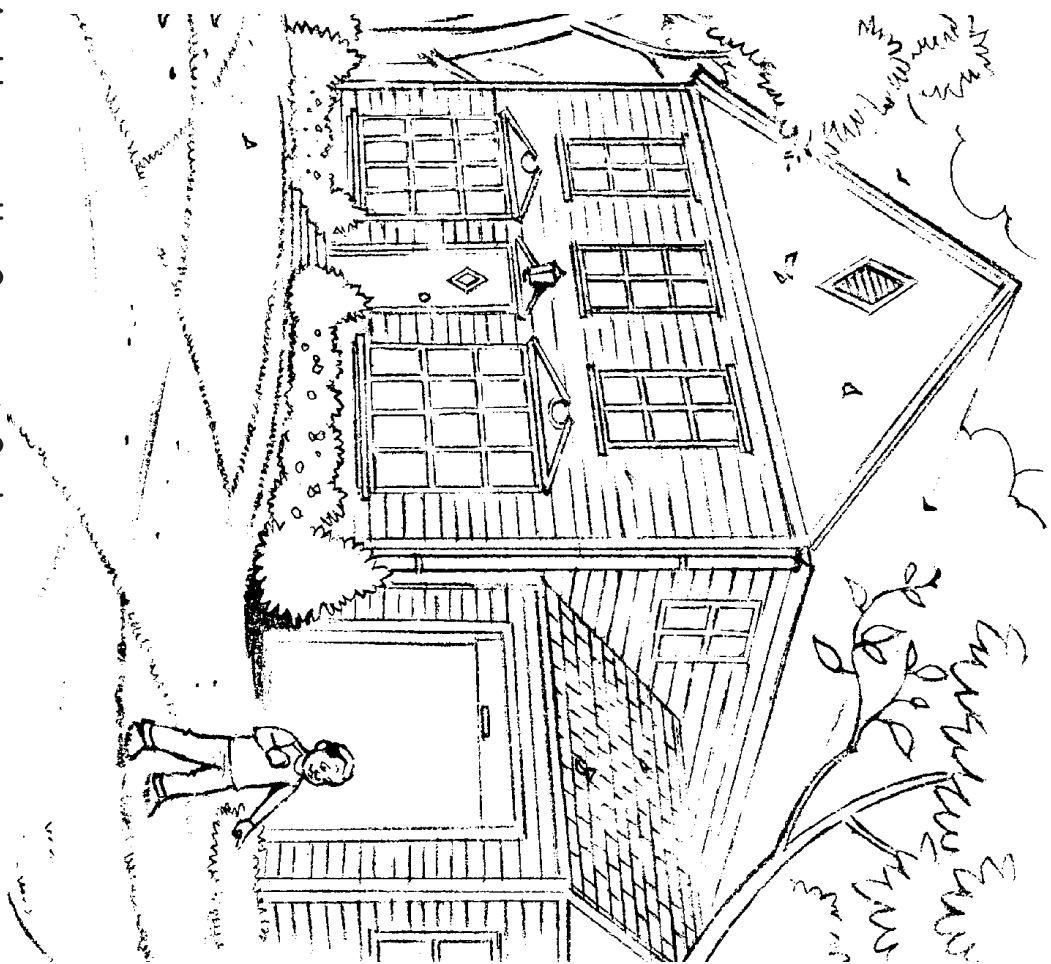

A blur with fur ran fast.  
It turned a corner and left tracks in the grass.

5



It is a pearl!  
Earnest got a shell and a pearl!

# Earnest's Search

by Judy Mills  
illustrated by Len Ebert

Core Decodable 51



Bothell, WA • Chicago, IL • Columbus, OH • New York, NY

MHEonline.com



Copyright © 2015 McGraw-Hill Education

All rights reserved. The contents, or parts thereof, may be reproduced in print form for non-profit educational use with *SRA Open Court Reading*, provided such reproductions bear copyright notice, but may not be reproduced in any form for any other purpose without the prior written consent of McGraw-Hill Education, including, but not limited to, network storage or transmission, or broadcast for distance learning.

Send all inquiries to:  
McGraw-Hill Education  
8787 Orion Place  
Columbus, OH 43240

2

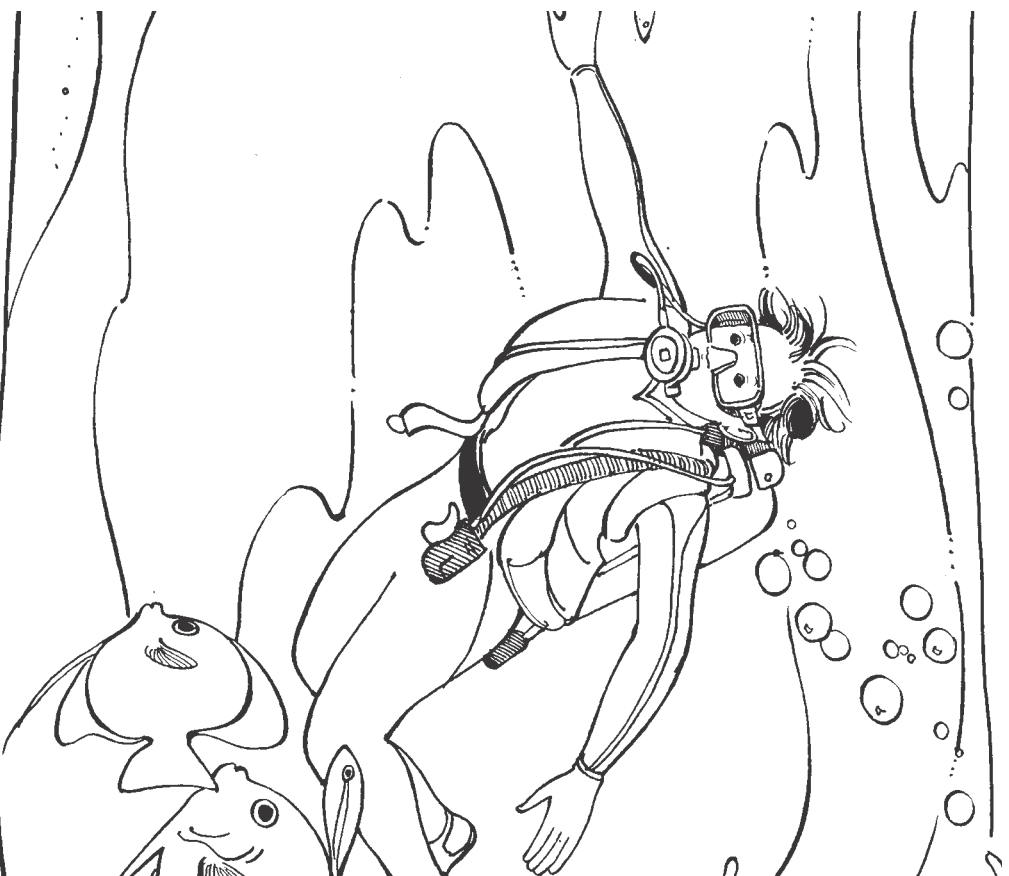

Earnest got a shell from the water.  
What is in it?

7



Earnest kept up his search.  
Did Earnest get any shells?

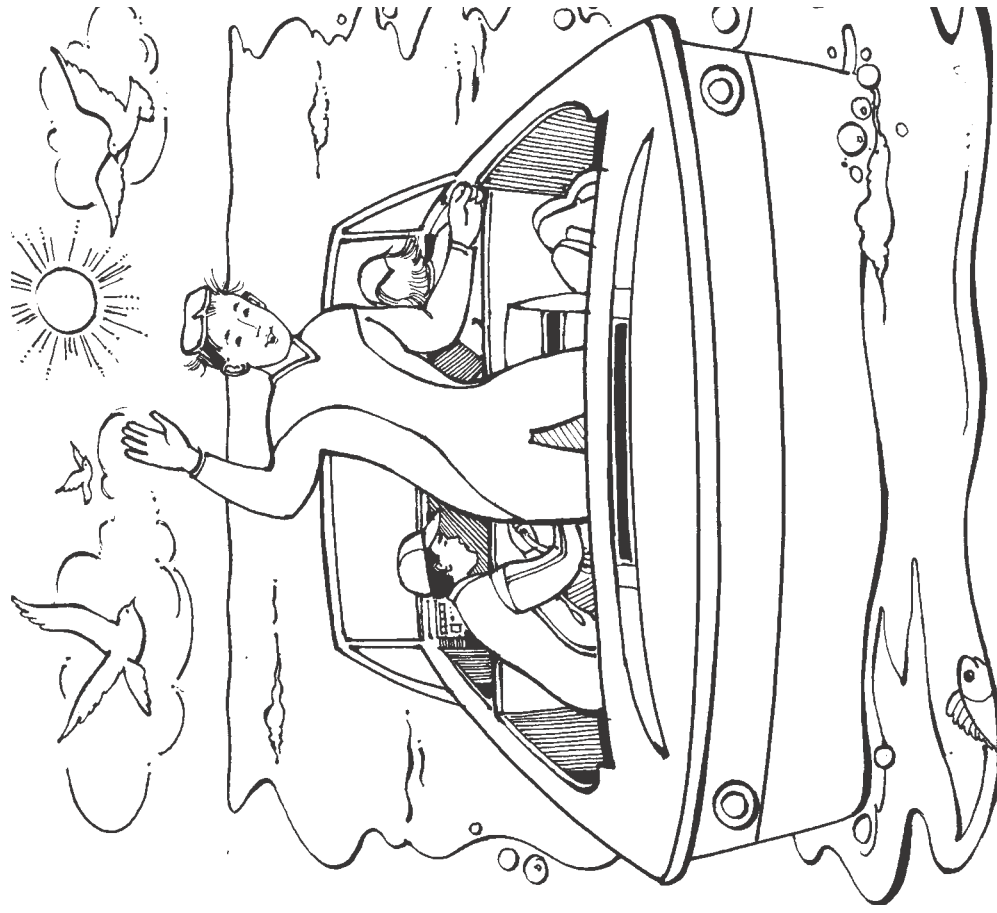

Earnest learned to swim.  
Earnest liked to swim.



Earnest liked to search under the water.



Earnest swam and searched.

Earnest searched for shells.





Hitting a big gong did it.  
Big Bing is up!

# Big Bing

by Andrea Patel  
illustrated by Kersti Frigell

Core Decodable 52



Bothell, WA • Chicago, IL • Columbus, OH • New York, NY



Banging will not.  
But hitting a big gong will.

MHEonline.com



Copyright © 2015 McGraw-Hill Education

All rights reserved. The contents, or parts thereof, may be reproduced in print form for non-profit educational use with SRA Open Court Reading, provided such reproductions bear copyright notice, but may not be reproduced in any form for any other purpose without the prior written consent of McGraw-Hill Education, including, but not limited to, network storage or transmission, or broadcast for distance learning.

Send all inquiries to:  
McGraw-Hill Education  
8787 Orion Place  
Columbus, OH 43240



Singing will not get Bing up.  
Will banging do it?



It is spring.  
But Big Bing is still resting.

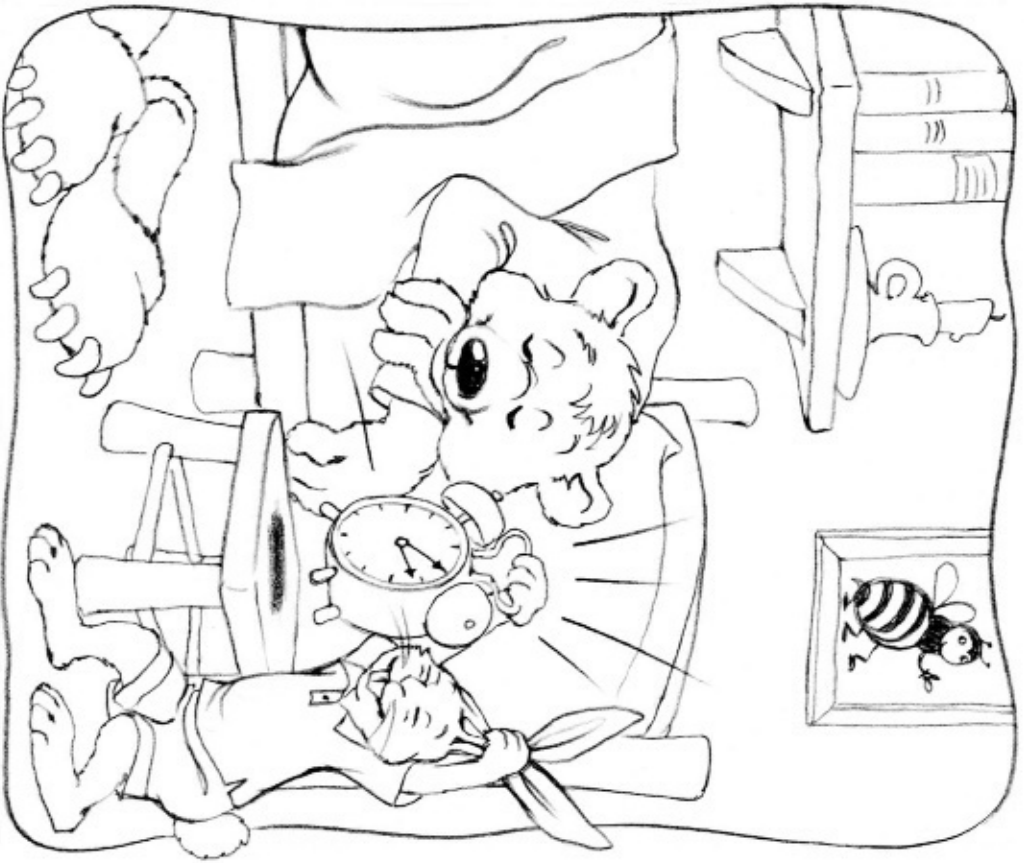

Bing must get up.

Will a long ring get Bing up?

4



A long ring will not do it.

Will a song do it?

5



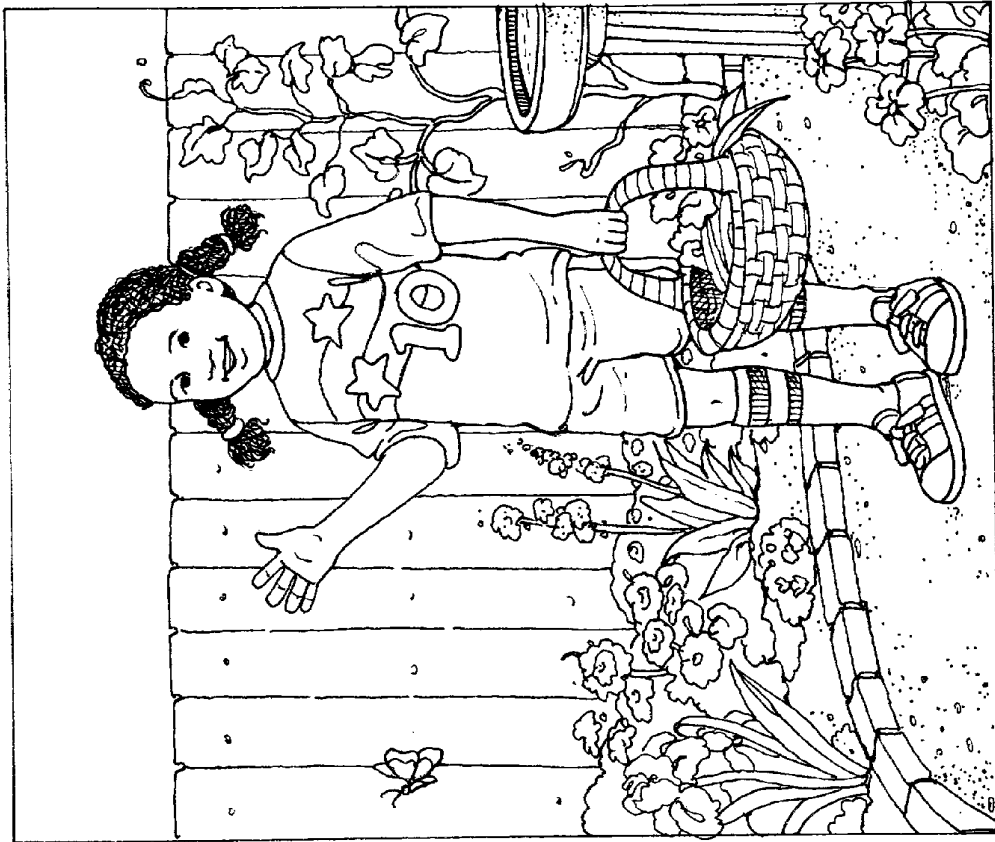

No matter where I turn,  
I see a blur of purple!

# Purple

by Maria Johnson  
illustrated by Susan Lexa

Core Decodable 53



Bothell, WA • Chicago, IL • Columbus, OH • New York, NY



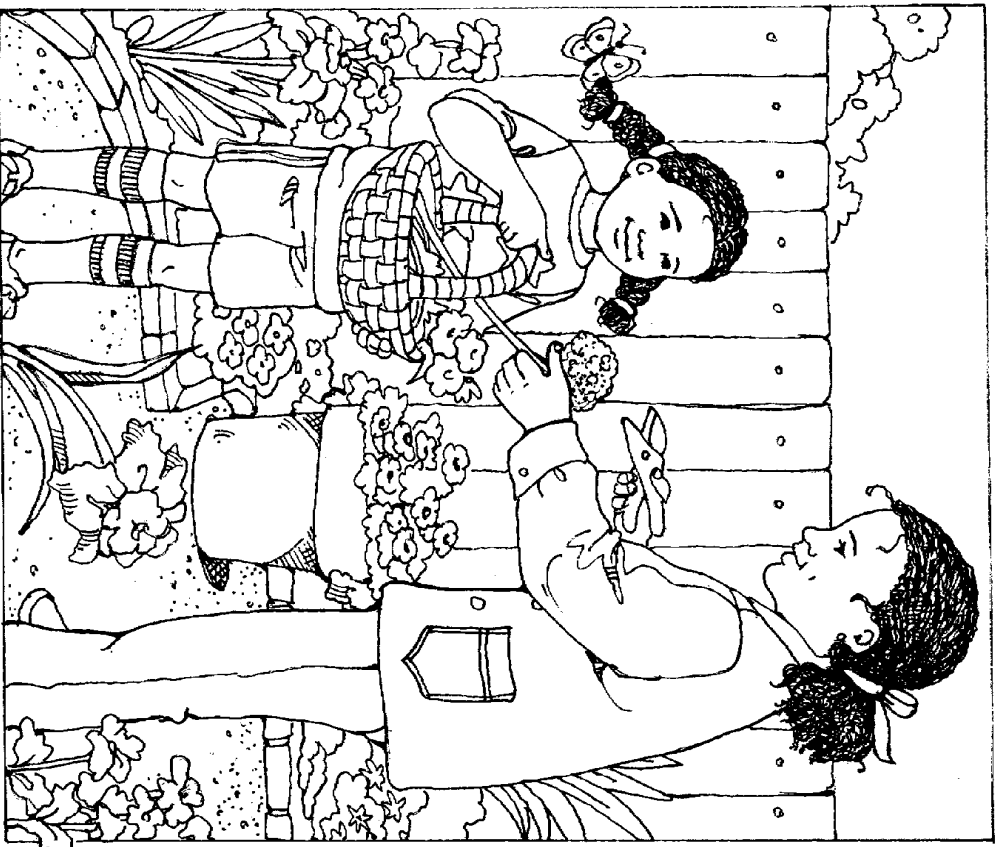

Mom gets purple plants  
from the earth.

MHEonline.com



Copyright © 2015 McGraw-Hill Education

All rights reserved. The contents, or parts thereof, may be reproduced in print form for non-profit educational use with SRA Open Court Reading, provided such reproductions bear copyright notice, but may not be reproduced in any form for any other purpose without the prior written consent of McGraw-Hill Education, including, but not limited to, network storage or transmission, or broadcast for distance learning.

Send all inquiries to:  
McGraw-Hill Education  
8787 Orion Place  
Columbus, OH 43240

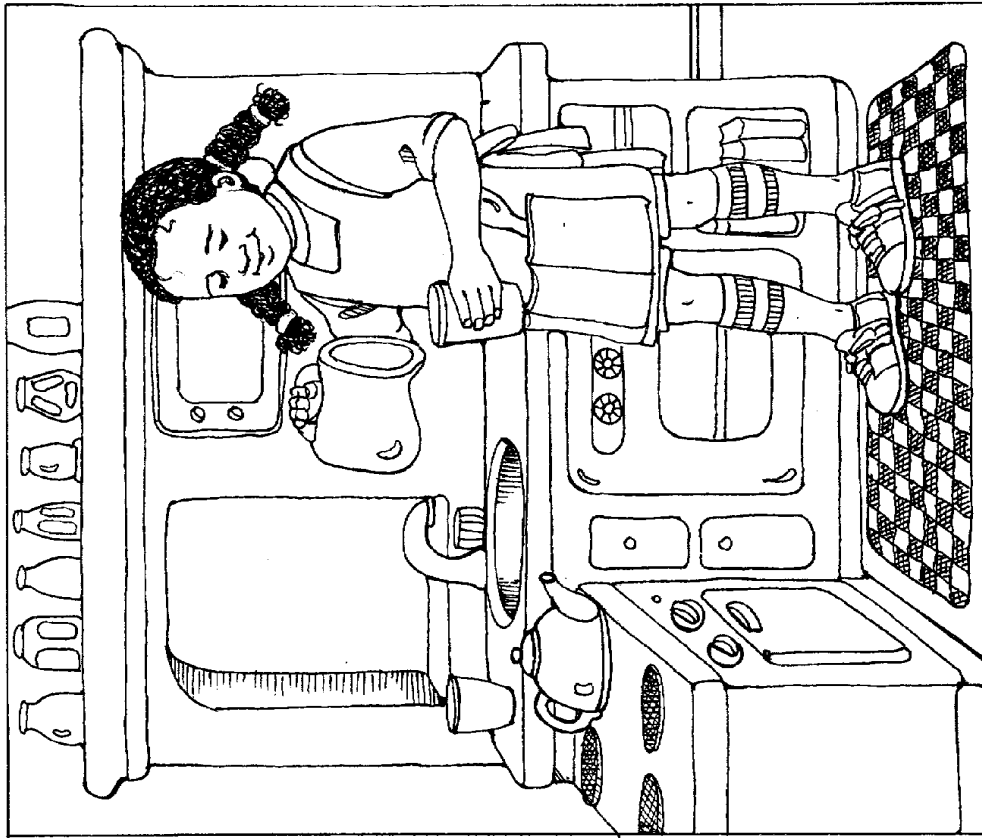

This pitcher has bursts of purple.

I am learning to fill cups.



I am a purple girl.

I have lots of purple things.

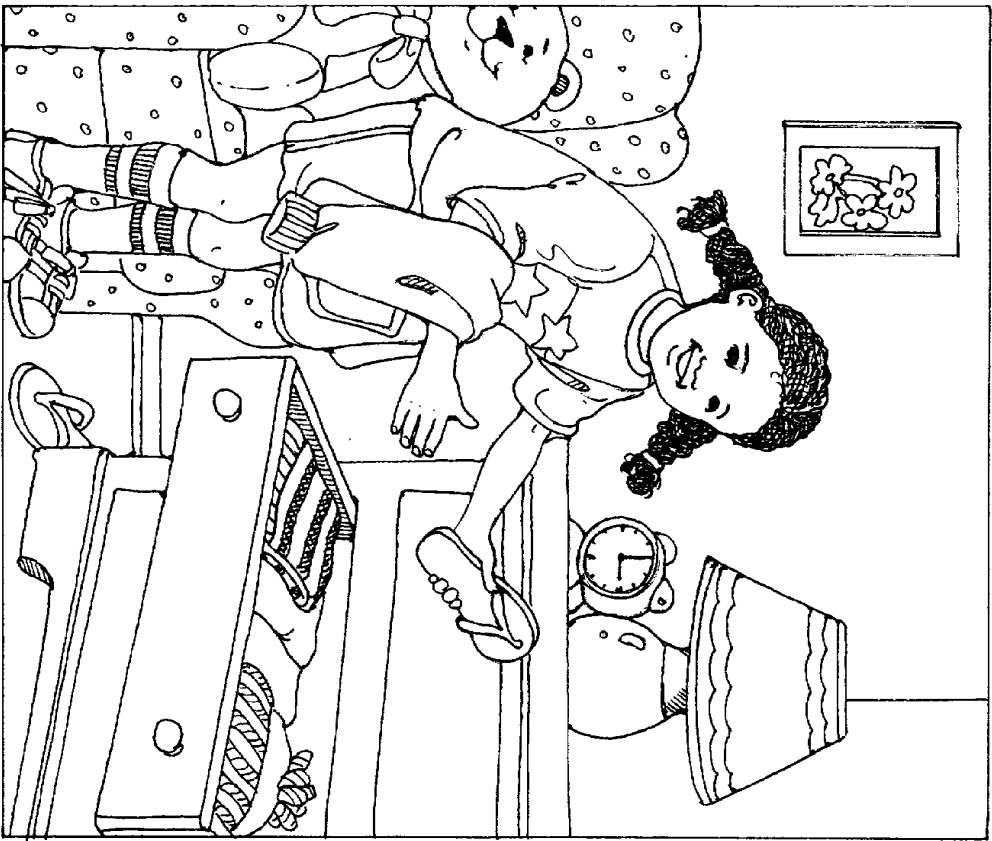

I set purple shirts, skirts, and  
pants in my purple dresser.

4

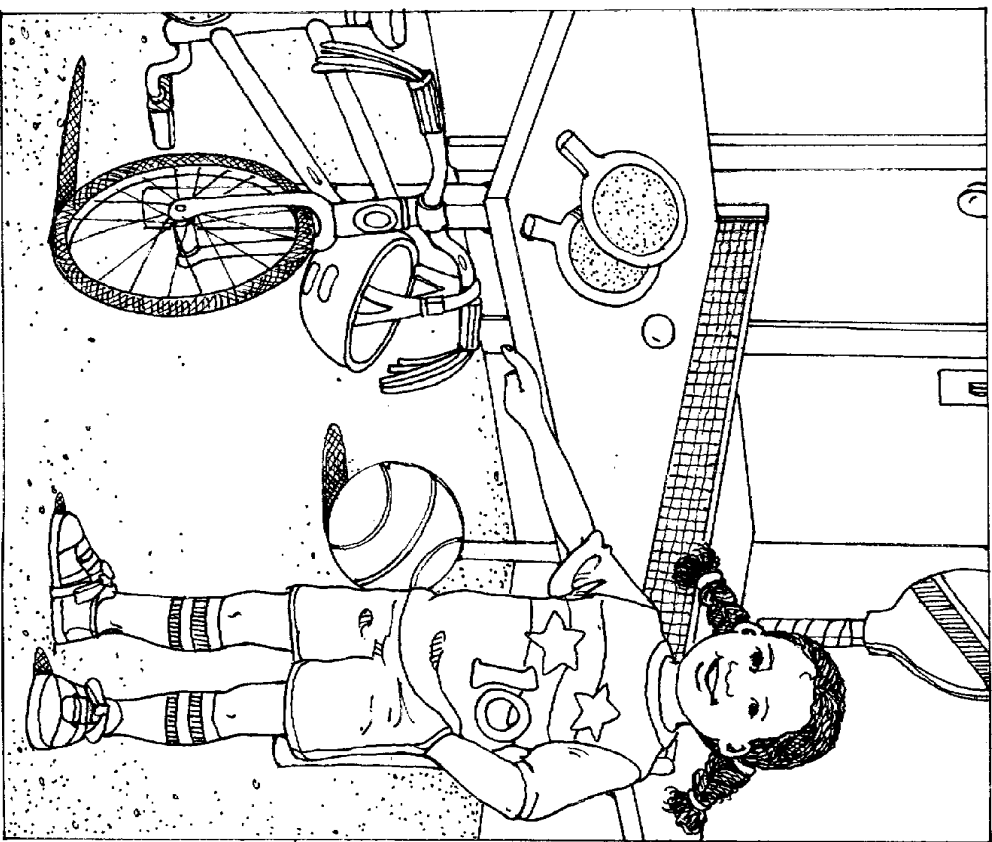

I have purple strings  
and purple ping pong stuff.

5

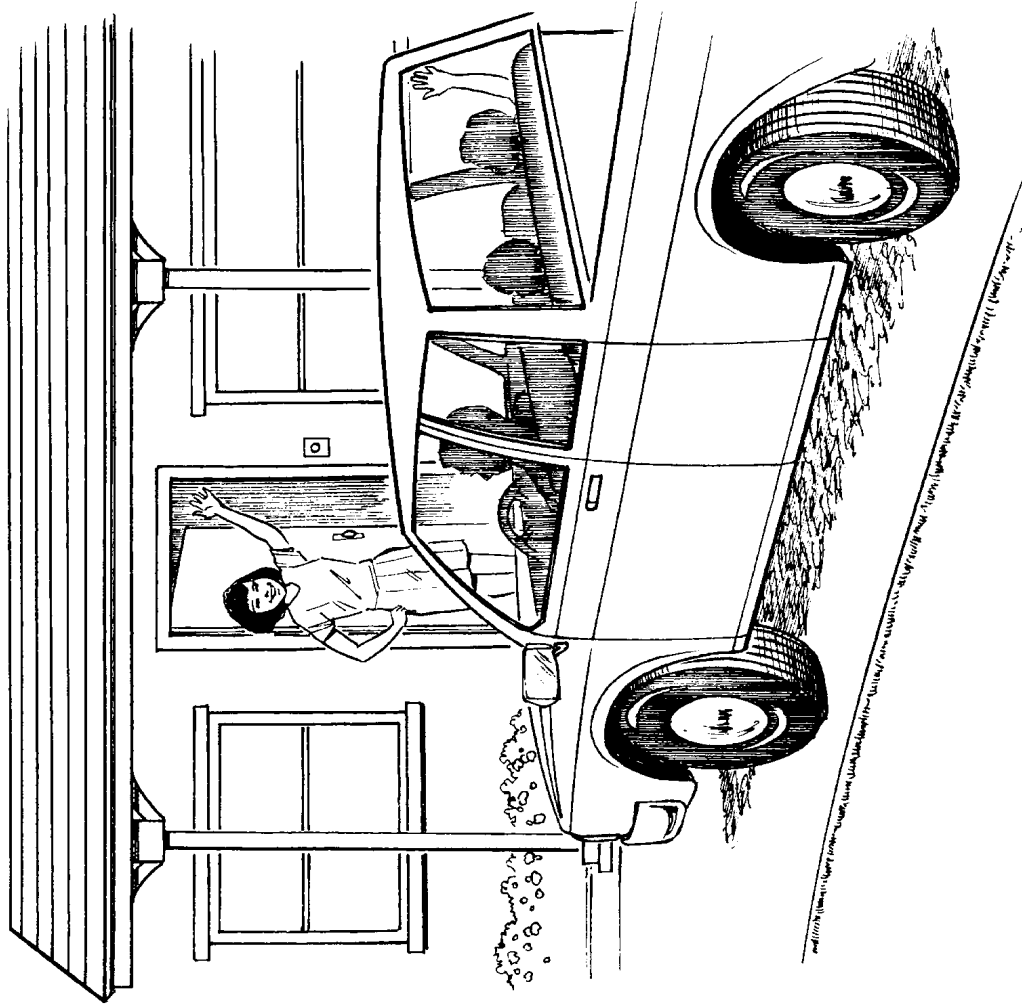

The children and Dad get in the truck.  
They had a fun trip!

# The Children Get a Rabbit

by Rob Hip  
illustrated by Barry Mullins

Core Decodable 54



Bothell, WA • Chicago, IL • Columbus, OH • New York, NY

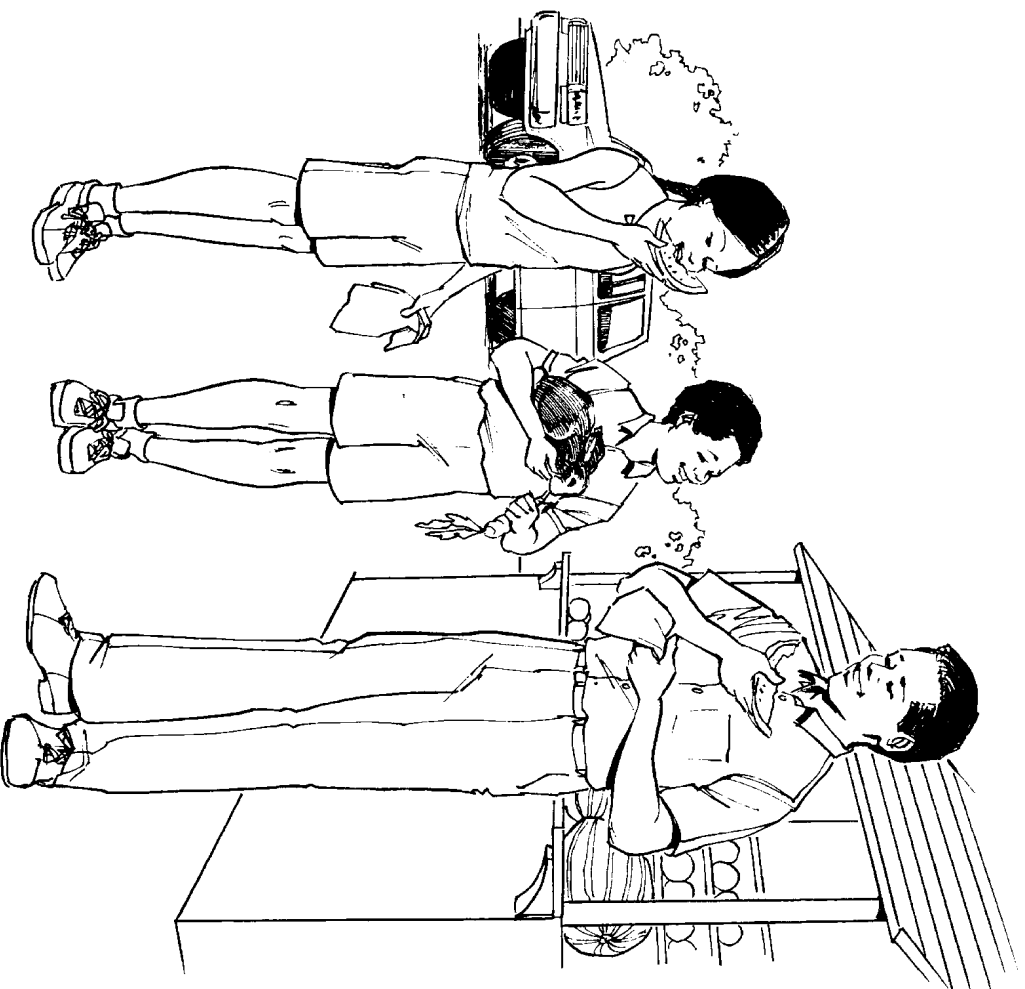

Dad and Ellen get melon.  
The rabbit has a carrot.

MHEonline.com



Copyright © 2015 McGraw-Hill Education

All rights reserved. The contents, or parts thereof, may be reproduced in print form for non-profit educational use with *SRA Open Court Reading*, provided such reproductions bear copyright notice, but may not be reproduced in any form for any other purpose without the prior written consent of McGraw-Hill Education, including, but not limited to, network storage or transmission, or broadcast for distance learning.

Send all inquiries to:  
McGraw-Hill Education  
8787 Orion Place  
Columbus, OH 43240



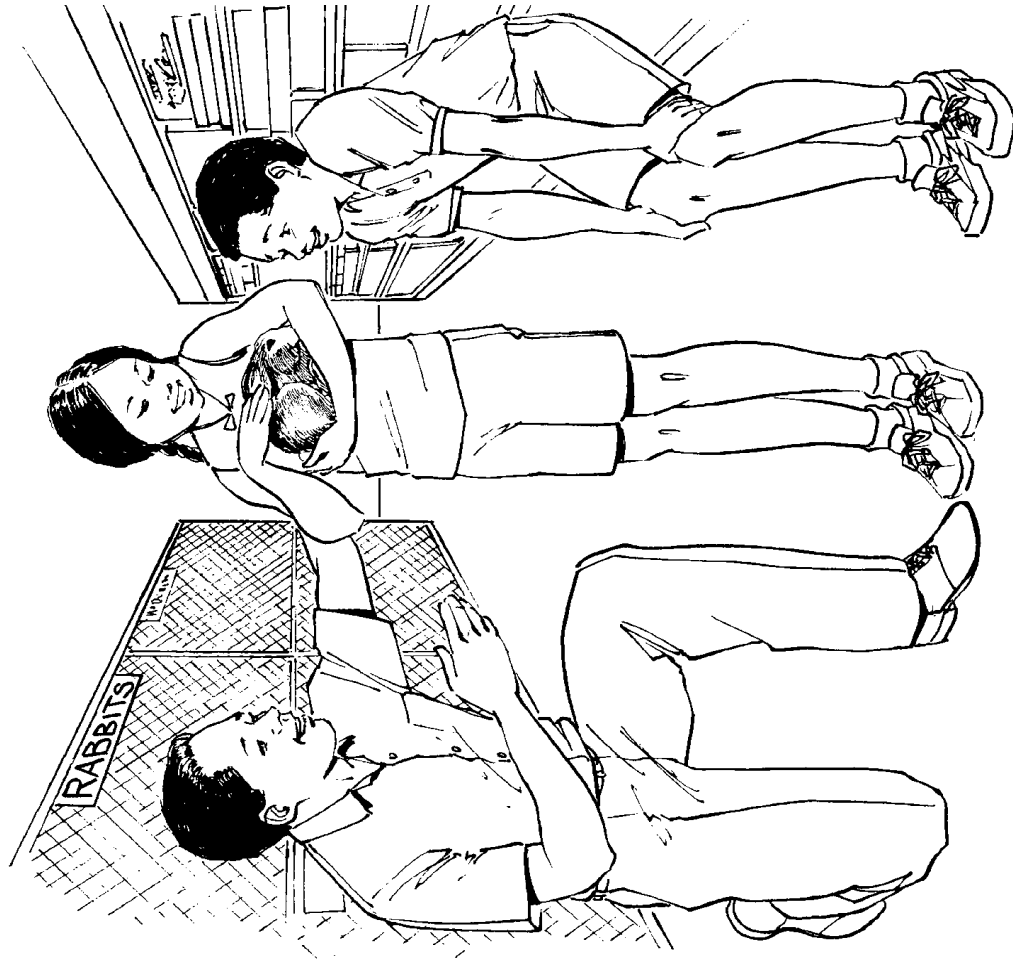

They pet a soft rabbit.  
“Dad, can I adopt him?” asks Ellen.

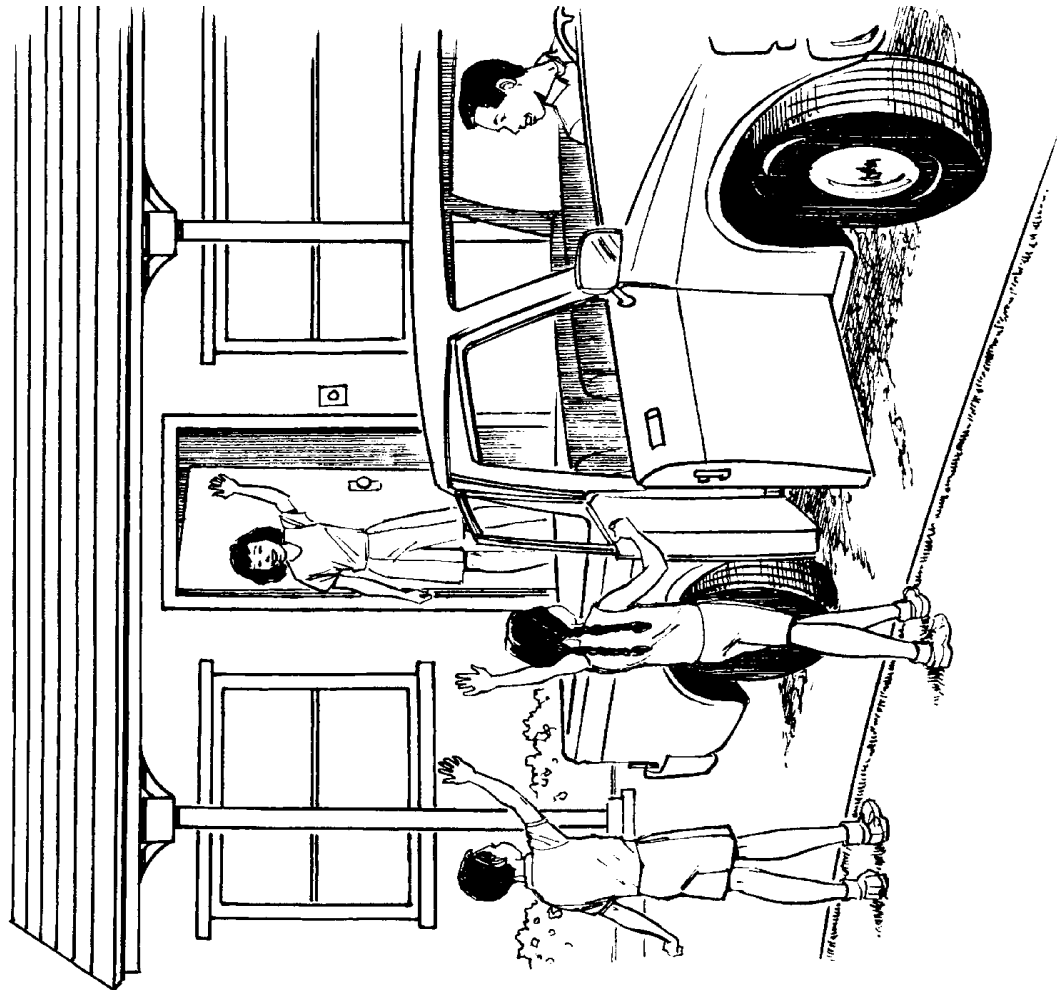

Dad and the children plan a trip.  
They get in a truck.

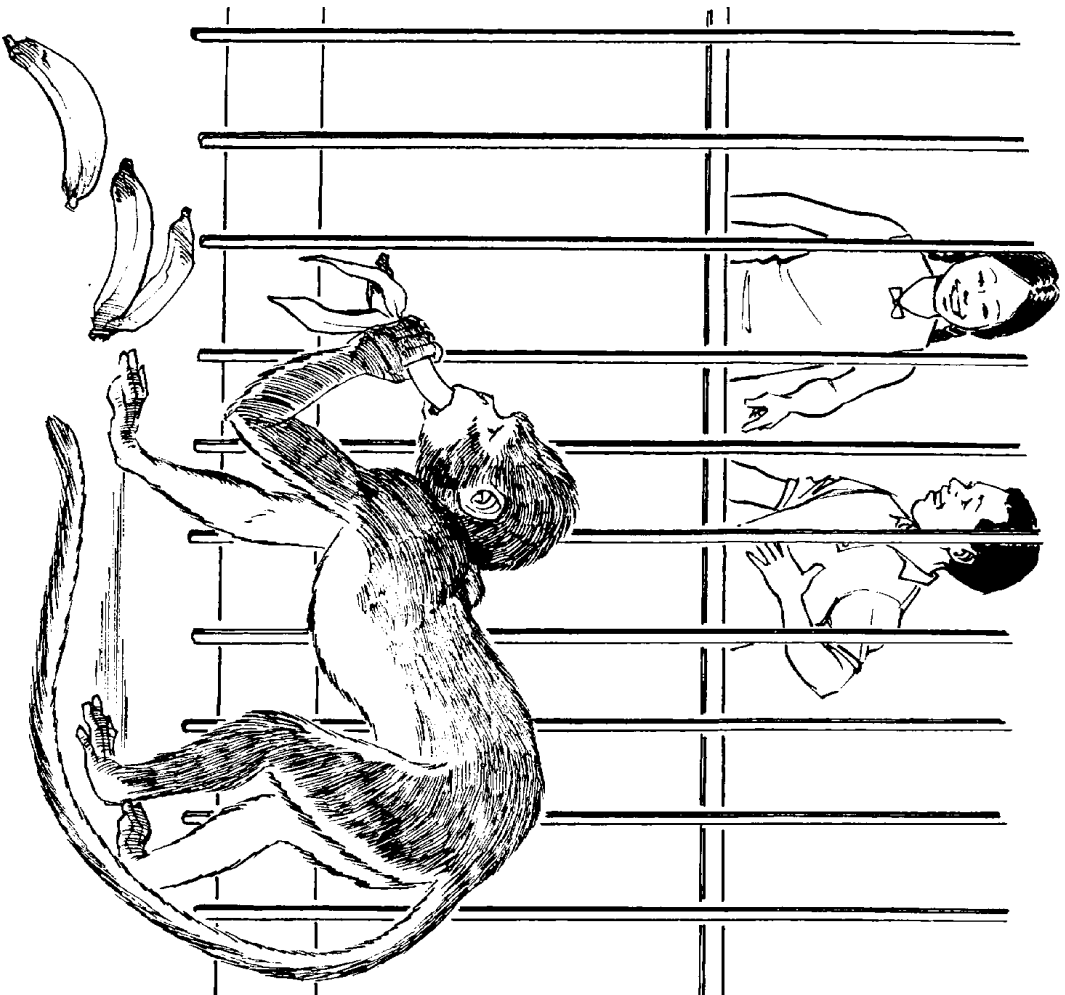

They see an animal with a banana.

4

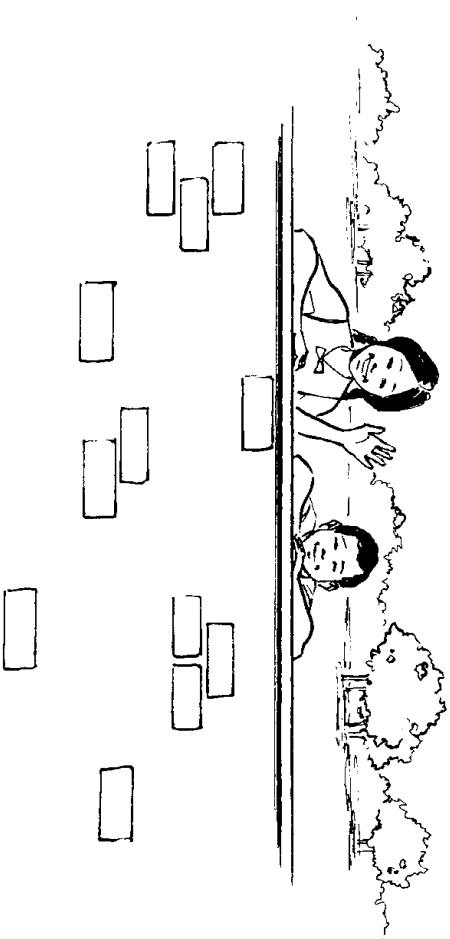

They see big pandas.

5

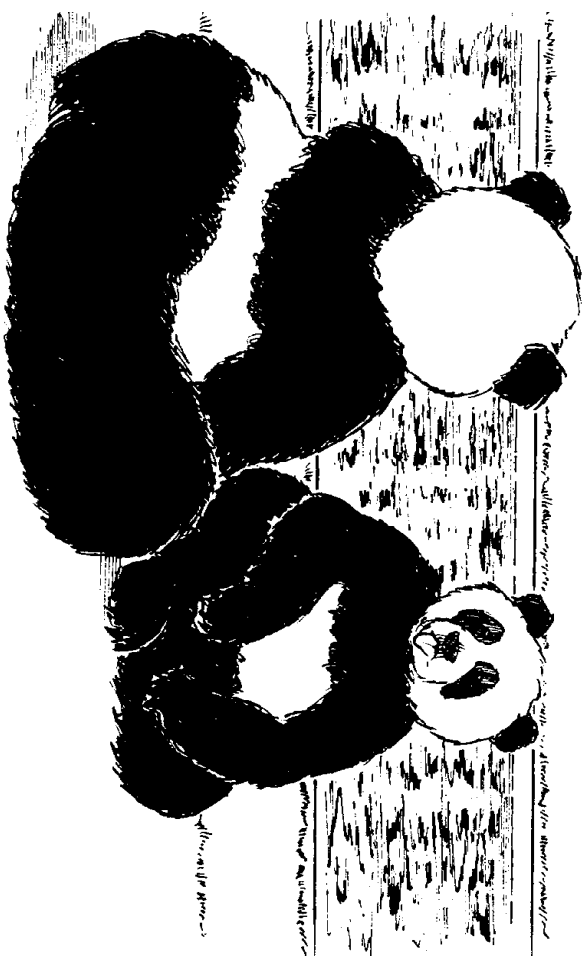

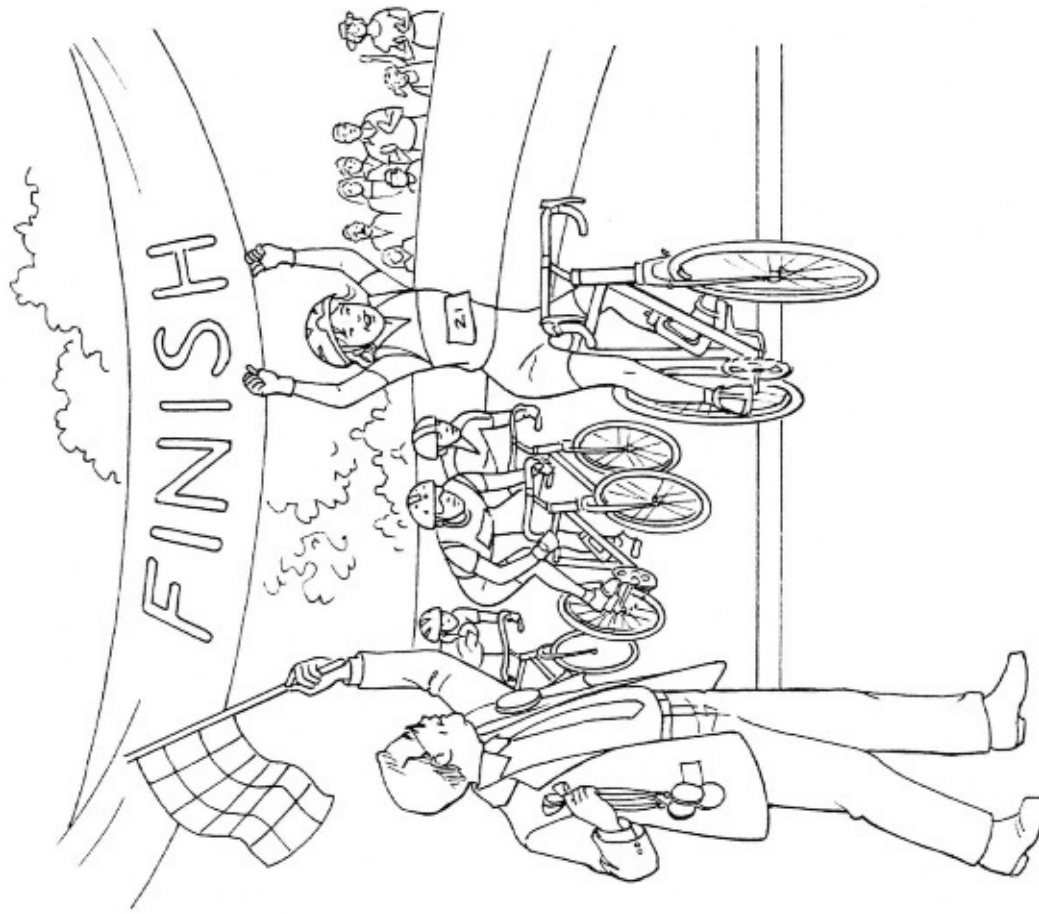

Pump to a fast finish.  
Win a medal, Pat!

# Pump and Pedal

by Natalie Lambert  
illustrated by Meryl Henderson

Core Decodable 55



Bothell, WA • Chicago, IL • Columbus, OH • New York, NY

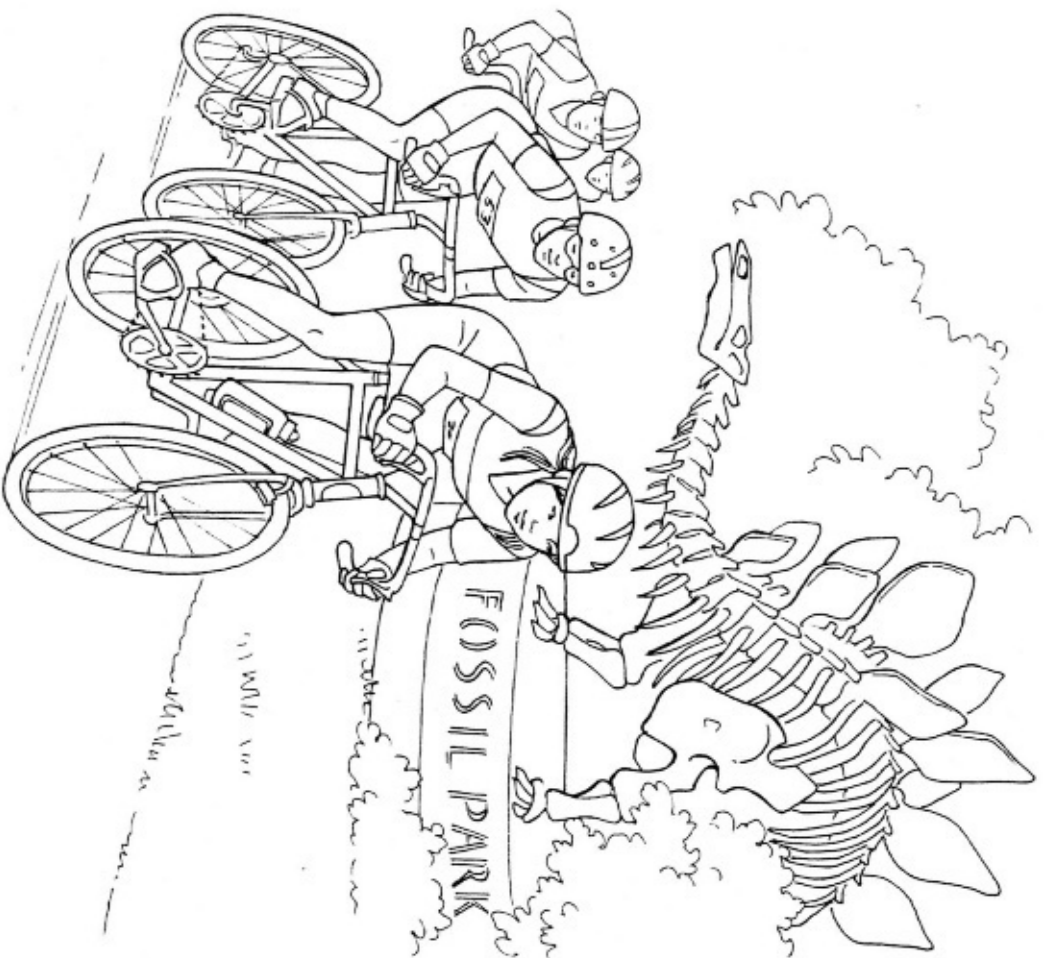

Pump in Fossil Park.  
Pedal! Pedal! Pedal!

MHEonline.com



Copyright © 2015 McGraw-Hill Education

All rights reserved. The contents, or parts thereof, may be reproduced in print form for non-profit educational use with *SRA Open Court Reading*, provided such reproductions bear copyright notice, but may not be reproduced in any form for any other purpose without the prior written consent of McGraw-Hill Education, including, but not limited to, network storage or transmission, or broadcast for distance learning.

Send all inquiries to:  
McGraw-Hill Education  
8787 Orion Place  
Columbus, OH 43240



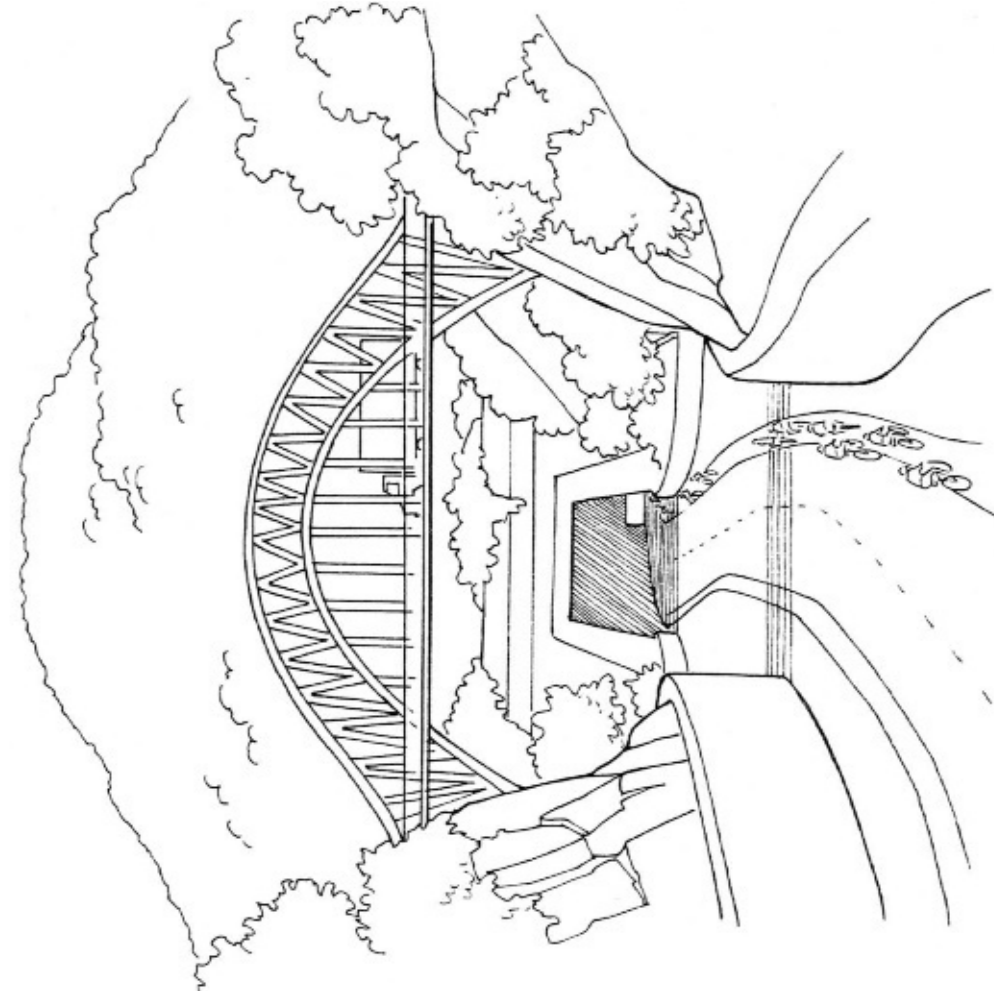

Pedal under the metal bridge.

Pump fast in the tunnel.

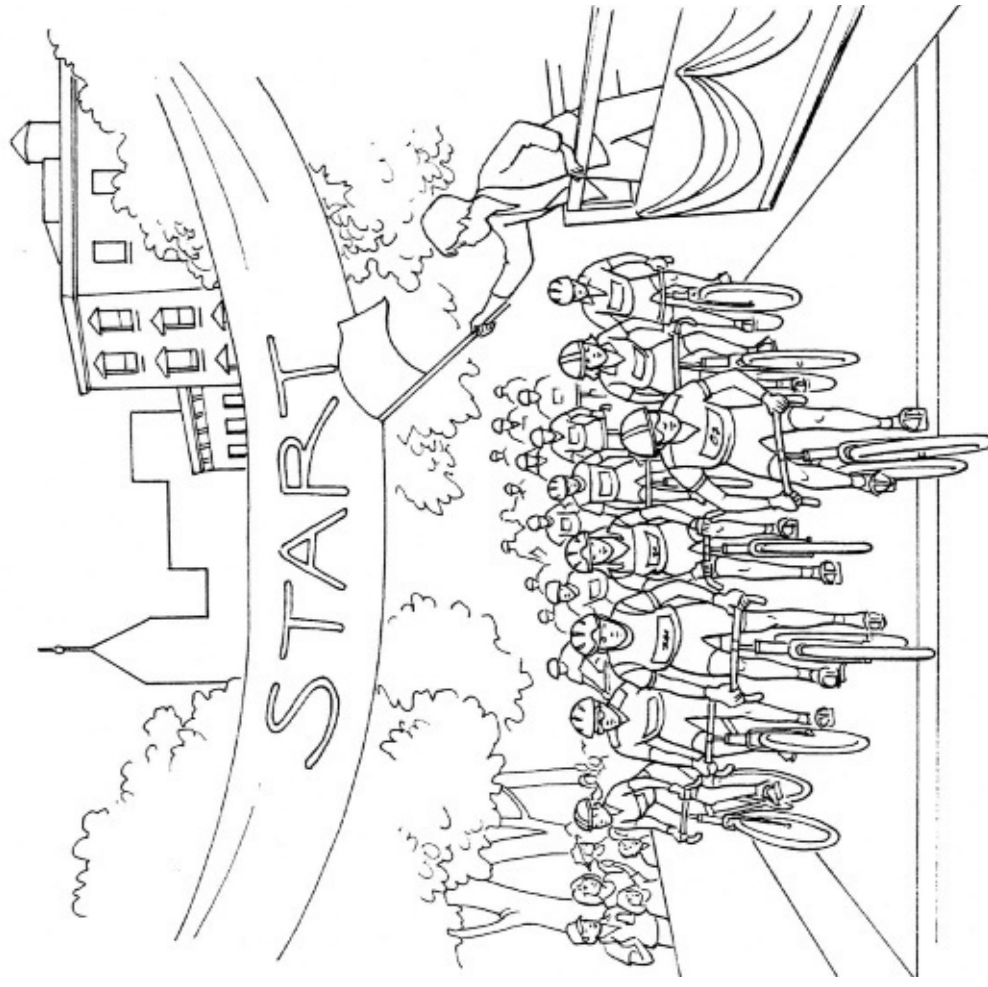

Pump fast at the signal, Pat.

Pedal to get ahead.



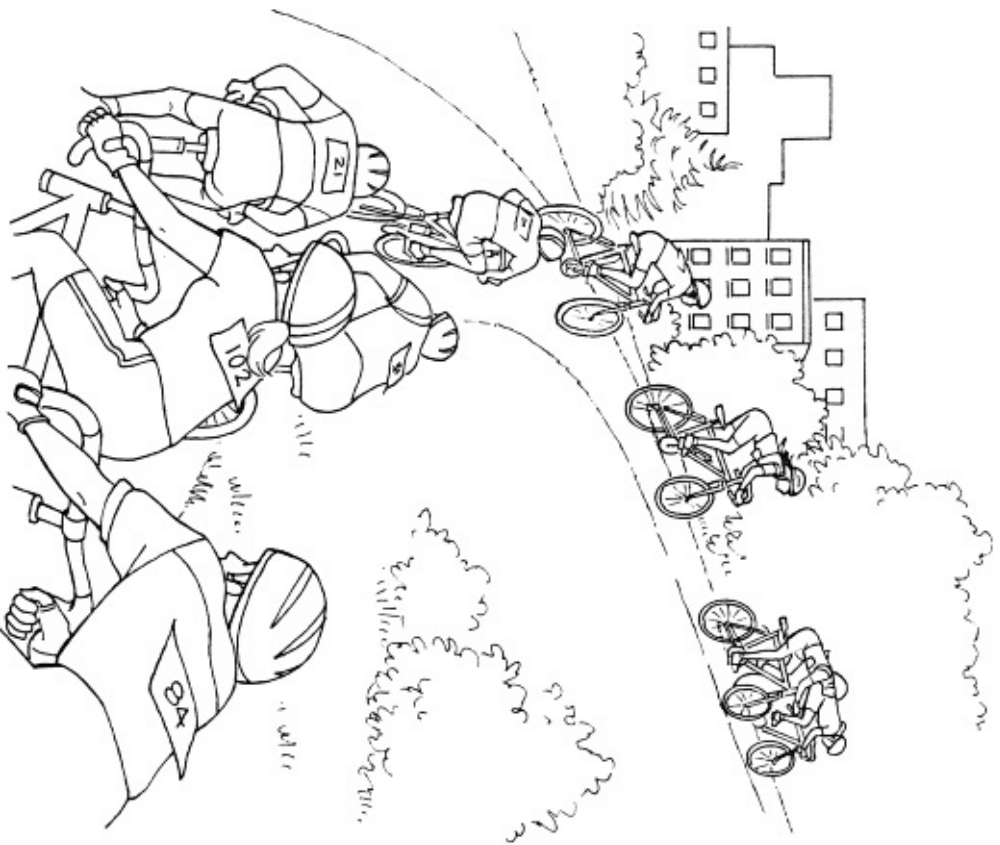

A big hill is not a problem.  
Just pump and pedal.

4

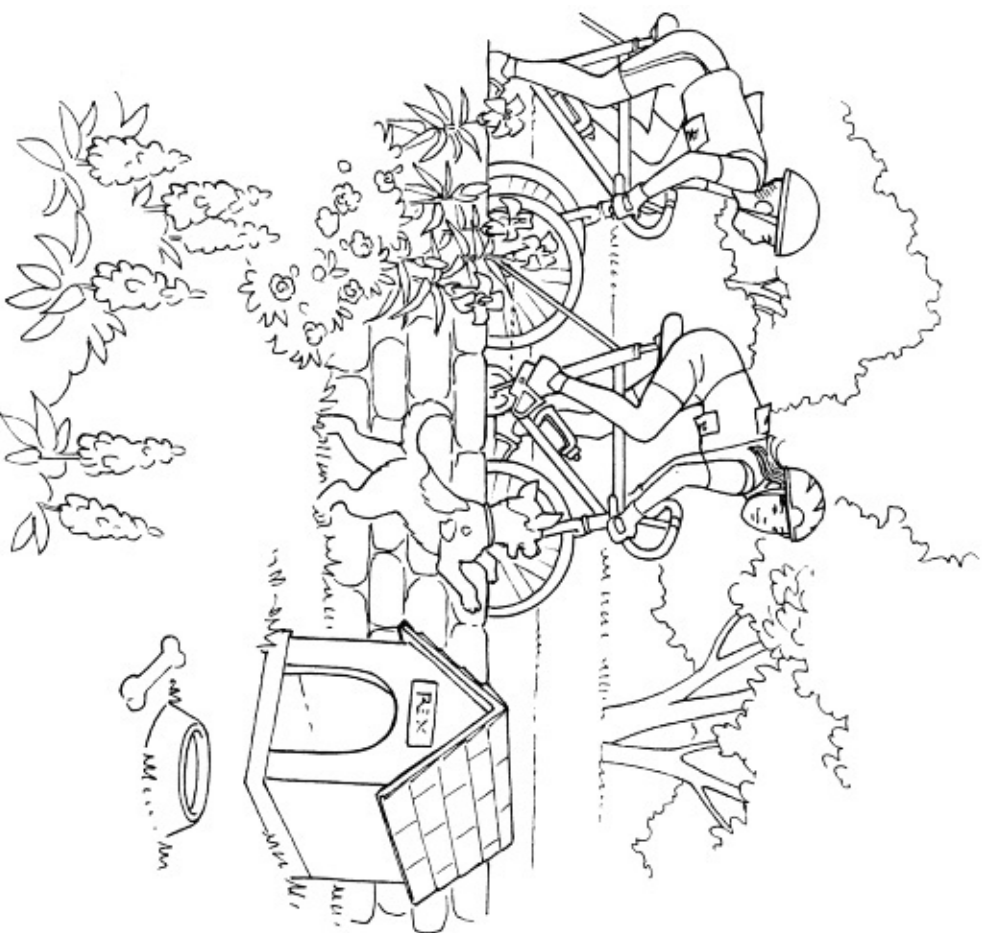

Pump past a garden and maple trees.  
Pedal next to the dog kennel.

5

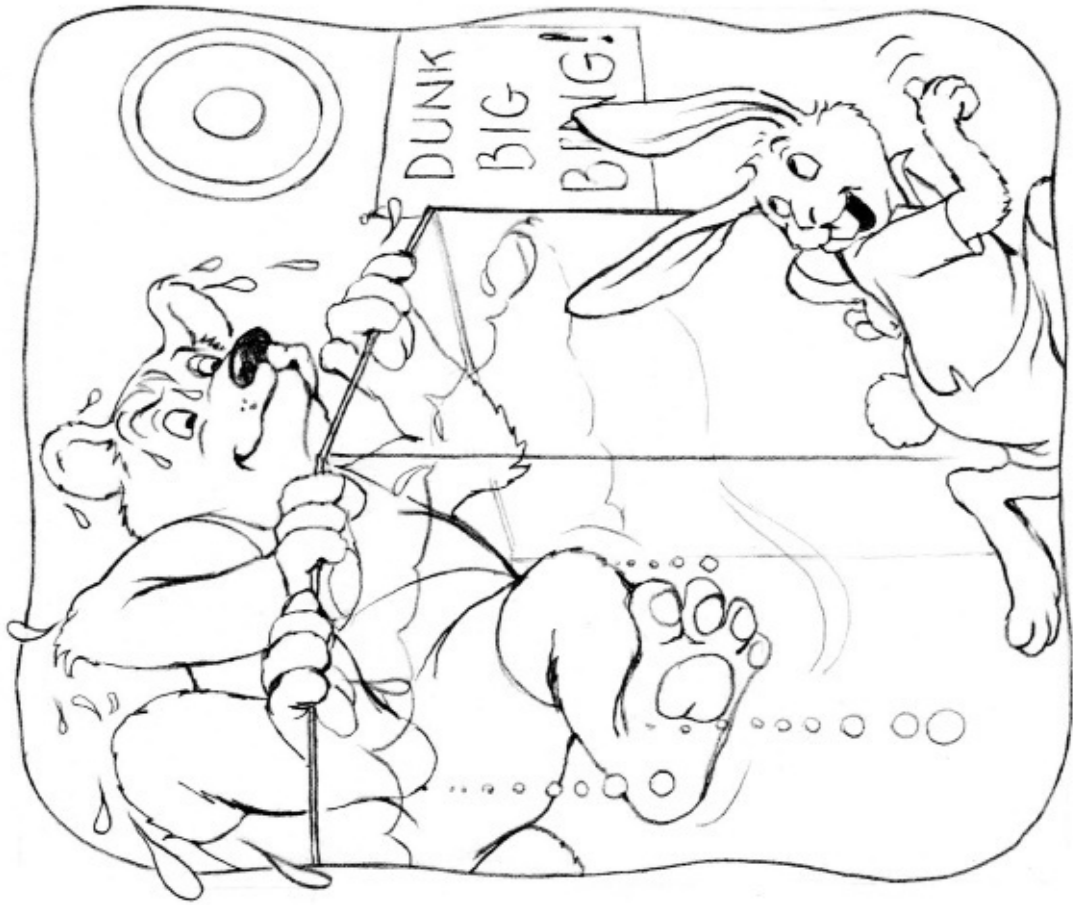

But he pops up fast.  
I think I better run.

# In the Tank

by Andrea Patel  
illustrated by Kersti Frigell

Core Decodable 56



Bothell, WA • Chicago, IL • Columbus, OH • New York, NY

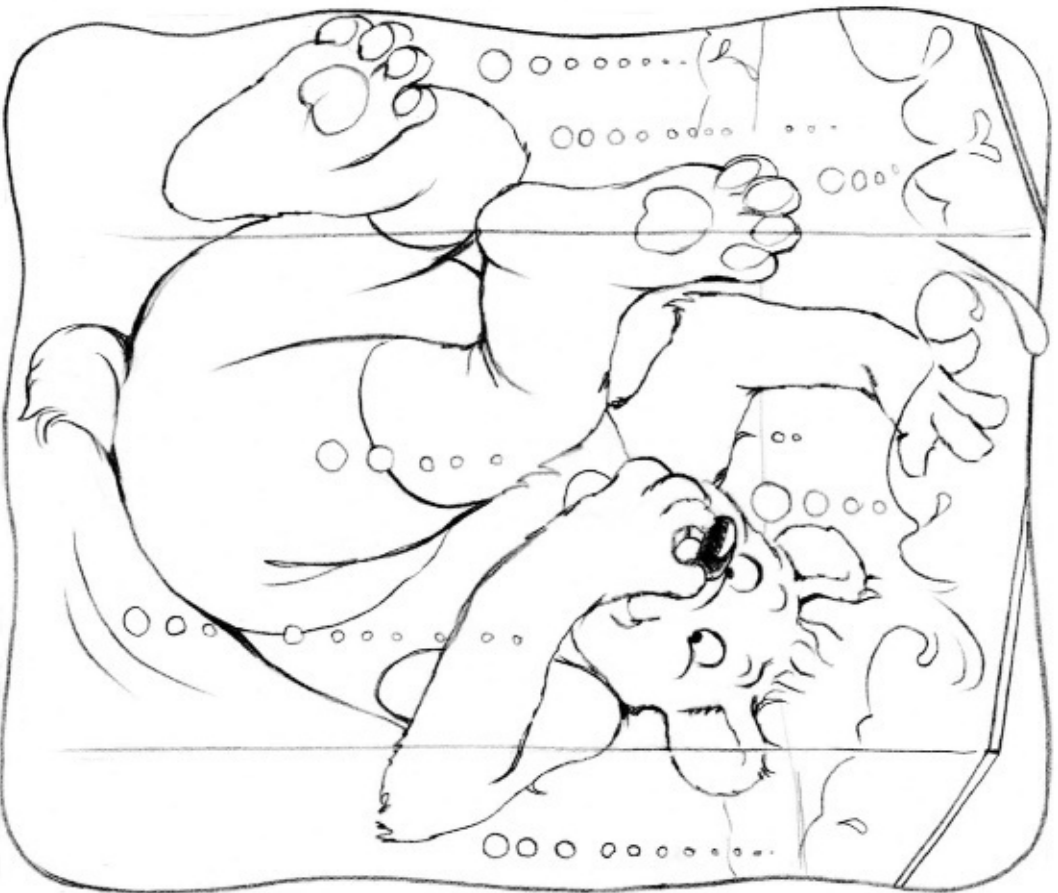

I did dunk Big Bingi!  
He sinks fast.

MHEonline.com



Copyright © 2015 McGraw-Hill Education

All rights reserved. The contents, or parts thereof, may be reproduced in print form for non-profit educational use with SRA Open Court Reading, provided such reproductions bear copyright notice, but may not be reproduced in any form for any other purpose without the prior written consent of McGraw-Hill Education, including, but not limited to, network storage or transmission, or broadcast for distance learning.

Send all inquiries to:  
McGraw-Hill Education  
8787 Orion Place  
Columbus, OH 43240

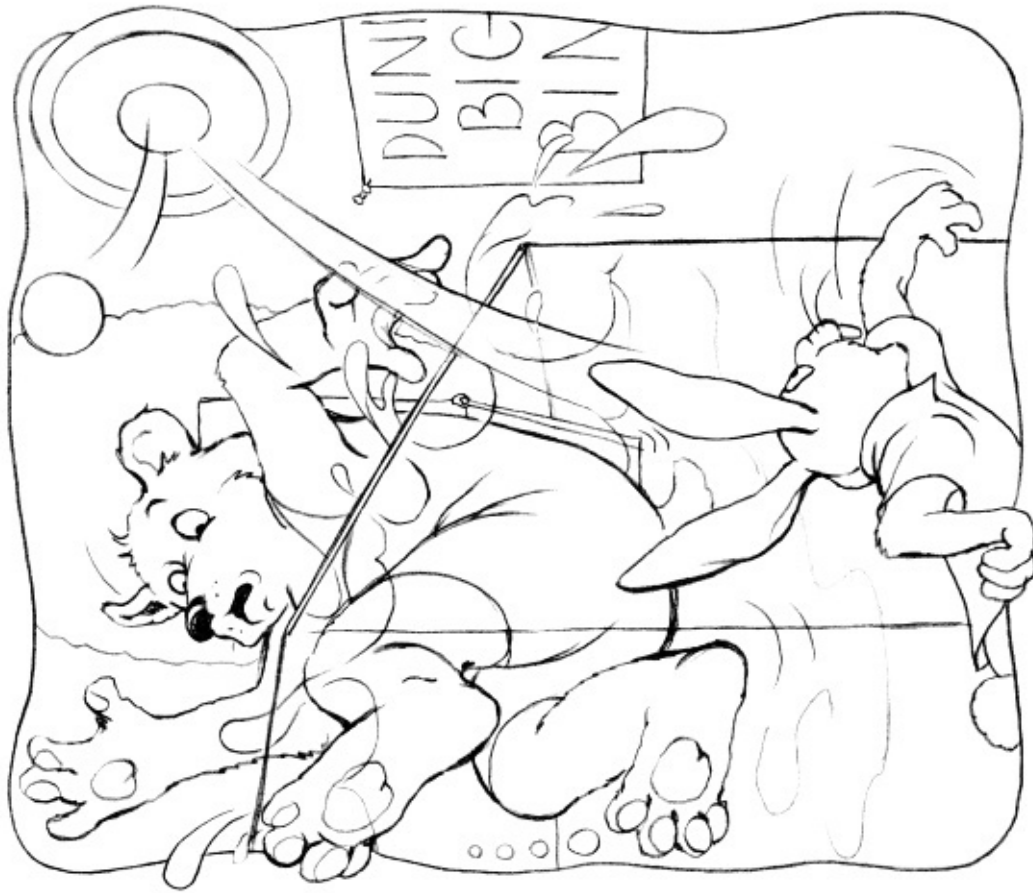

Plunk! I hit the pink spot.  
Splash! He is in the tank.

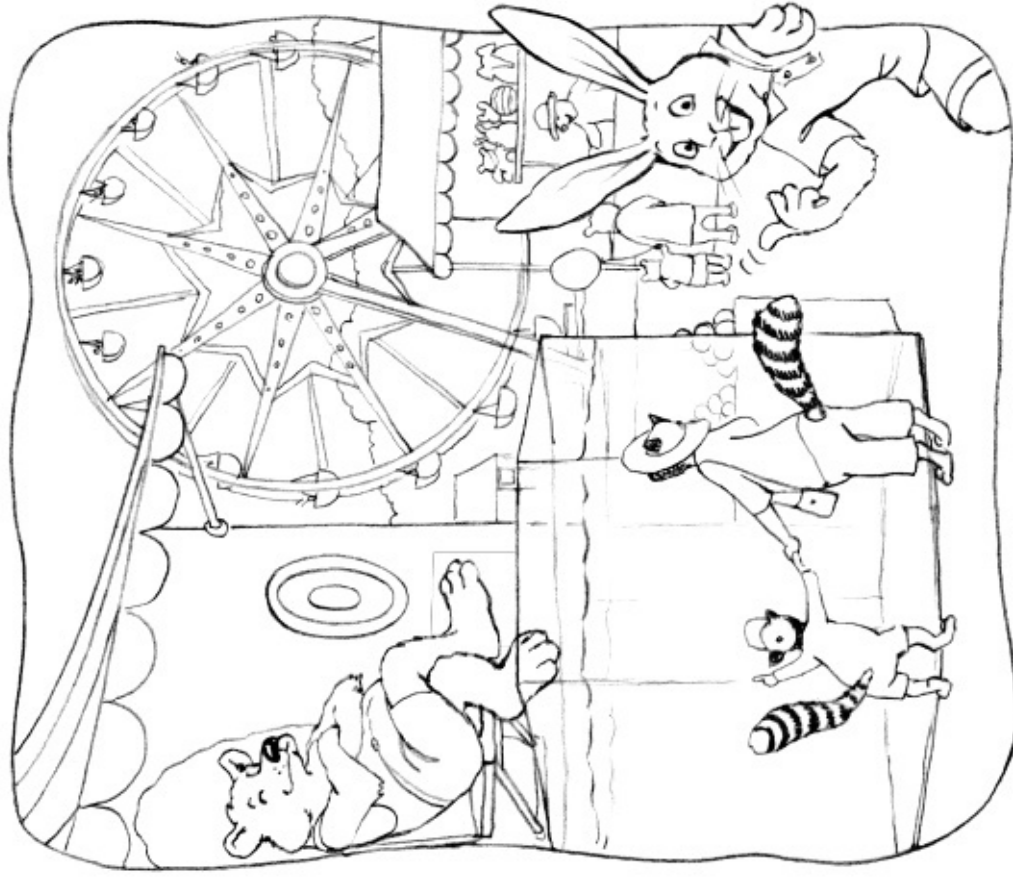

Big Bing sits on the tank.  
See the pink spot?





I can hit the pink spot.

I can dunk Big Bing.

4

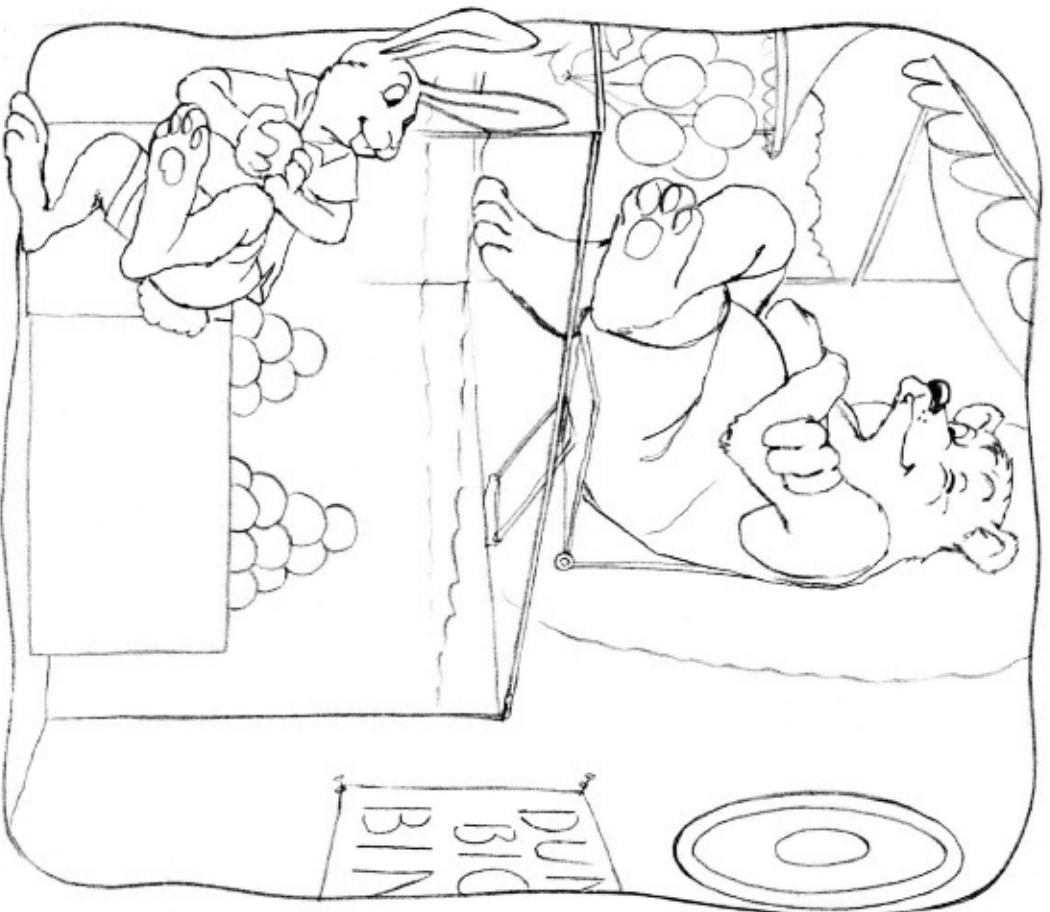

Big Bing winks.

He thinks I can't dunk him.

5





Did the liquid get on the quilt?

Not a drop got on the quilt!

# Quick Quin

by David Nguyen  
illustrated by Olivia Cole

Core Decodable 57



Bothell, WA • Chicago, IL • Columbus, OH • New York, NY

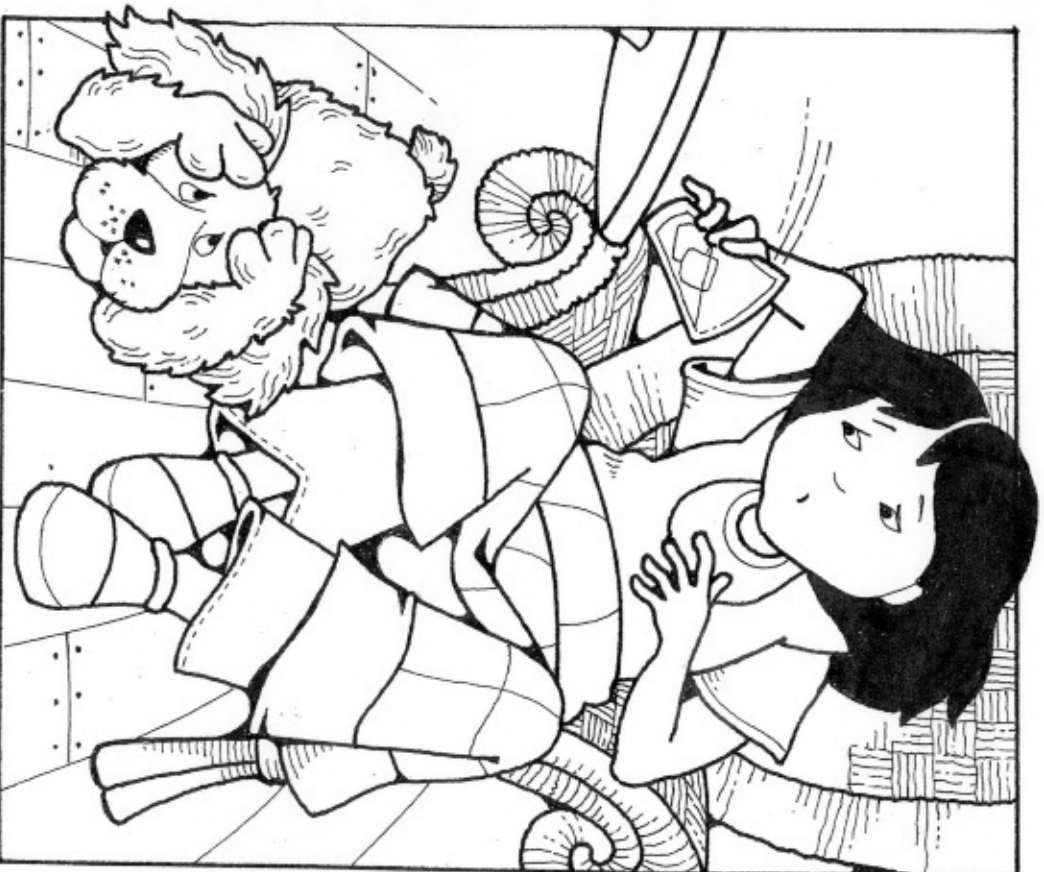

Quin was quick.  
She got her glass.

MHEonline.com



Copyright © 2015 McGraw-Hill Education

All rights reserved. The contents, or parts thereof, may be reproduced in print form for non-profit educational use with SRA Open Court Reading, provided such reproductions bear copyright notice, but may not be reproduced in any form for any other purpose without the prior written consent of McGraw-Hill Education, including, but not limited to, network storage or transmission, or broadcast for distance learning.

Send all inquiries to:  
McGraw-Hill Education  
8787 Orion Place  
Columbus, OH 43240

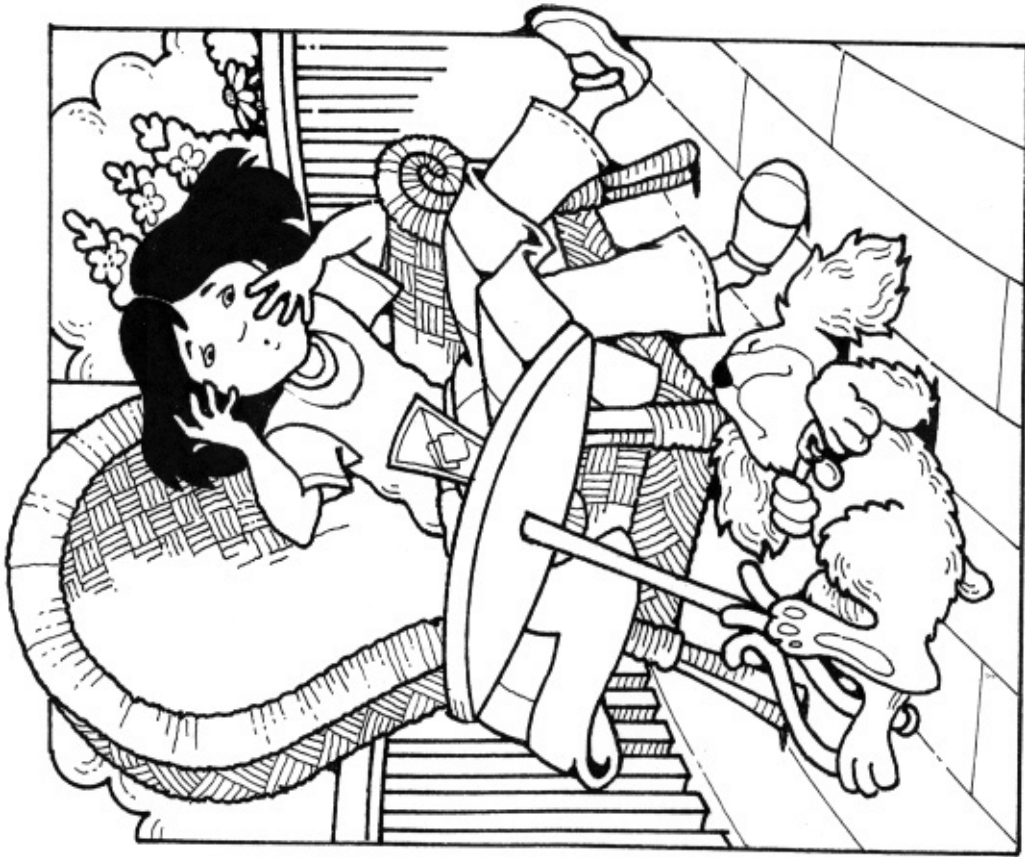

Max did not quit squirming.  
He hit her drink.



Quin sat on her porch.  
She rested on a quilt.



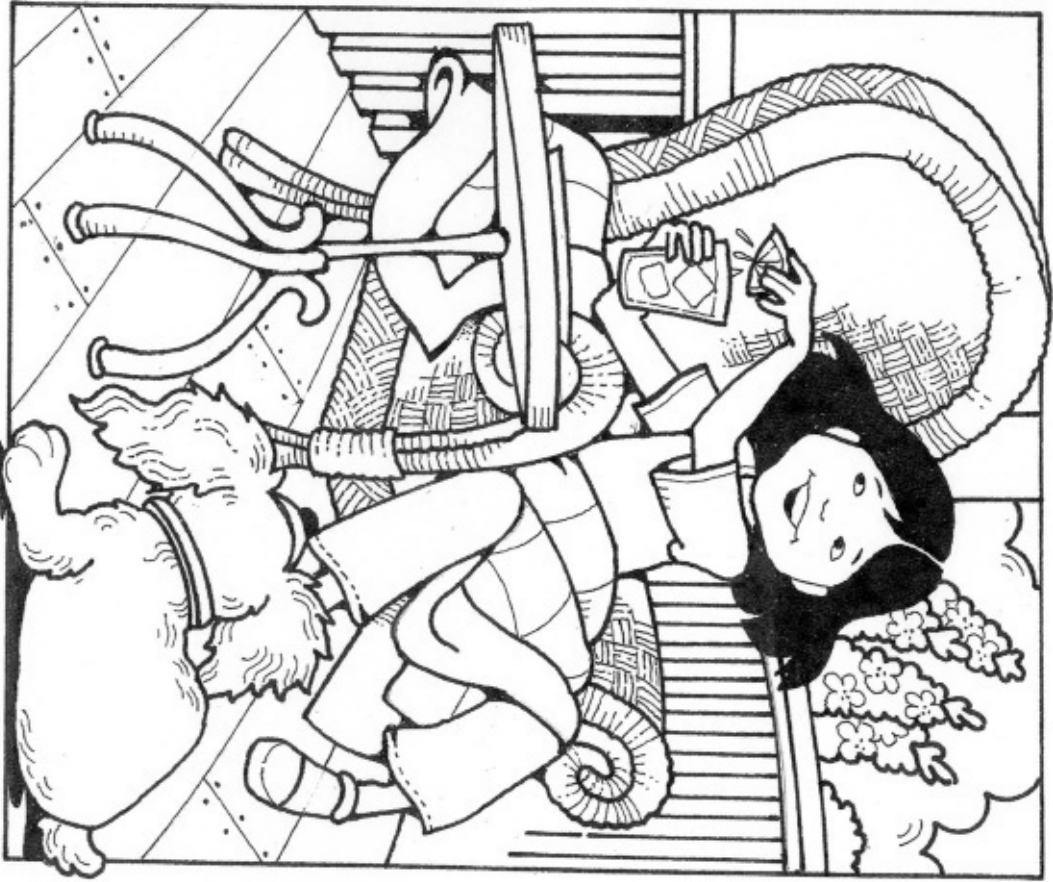

Quin was hot on her porch.

She squirted lemon in her drink.

4



Max was squirming on Quin.

“Quit squirming, Max,” she said.

5



Sir Quint grinned.  
King Frank was not resting.

# King Frank

by Ethan Cruz  
illustrated by Benton Mahan

Core Decodable 58



Bothell, WA • Chicago, IL • Columbus, OH • New York, NY



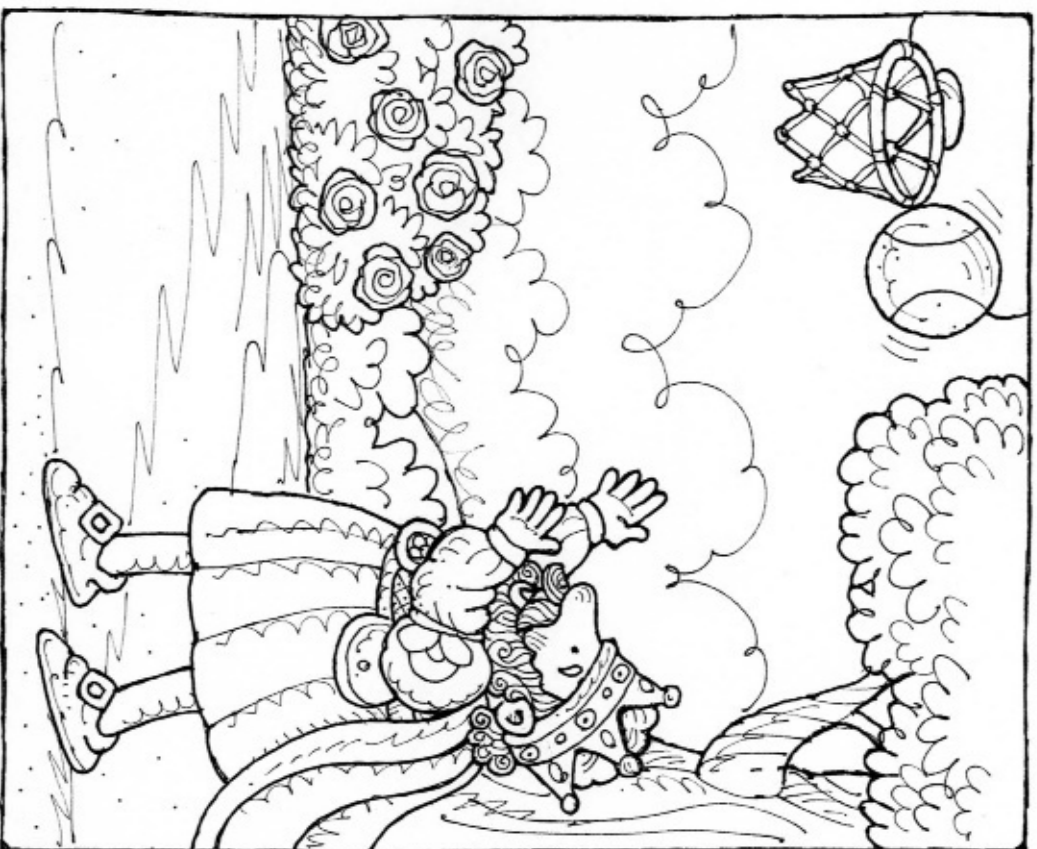

King Frank had a long shot!  
Clank! He missed his shot.

MHEonline.com



Copyright © 2015 McGraw-Hill Education

All rights reserved. The contents, or parts thereof, may be reproduced in print form for non-profit educational use with *SRA Open Court Reading*, provided such reproductions bear copyright notice, but may not be reproduced in any form for any other purpose without the prior written consent of McGraw-Hill Education, including, but not limited to, network storage or transmission, or broadcast for distance learning.

Send all inquiries to:  
McGraw-Hill Education  
8787 Orion Place  
Columbus, OH 43240

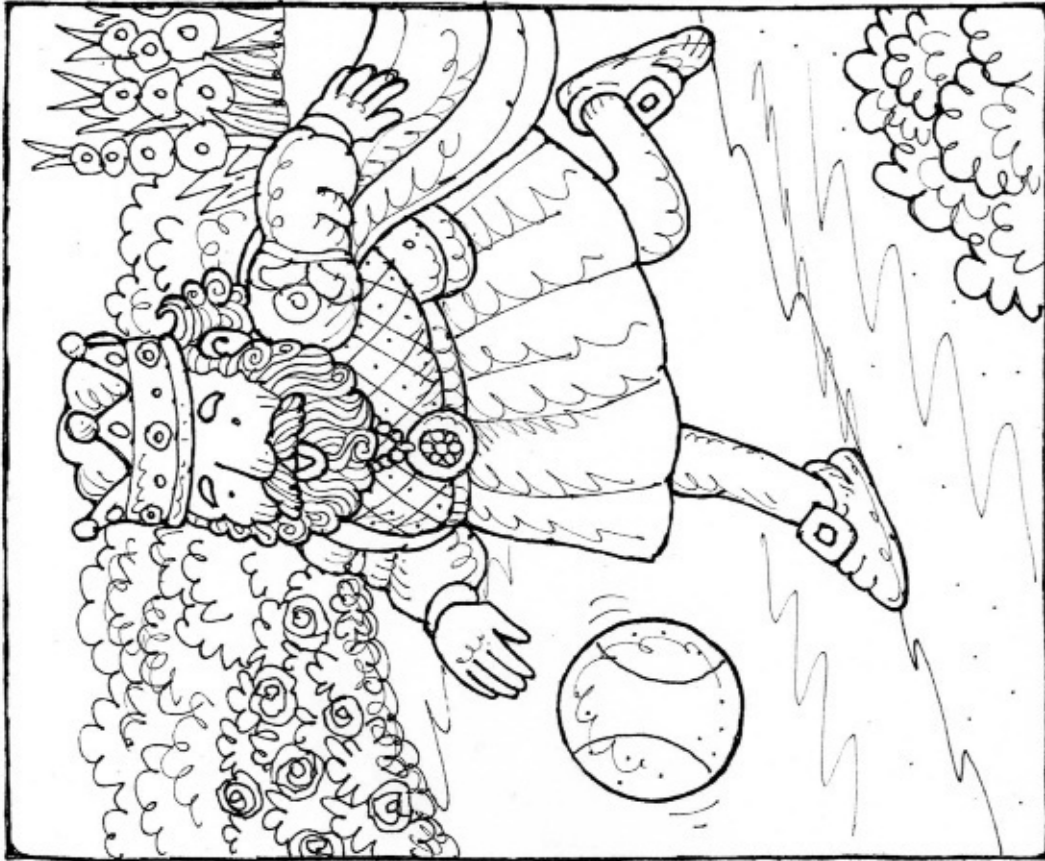

King Frank had a ball.  
Bang! Bang! Bang!

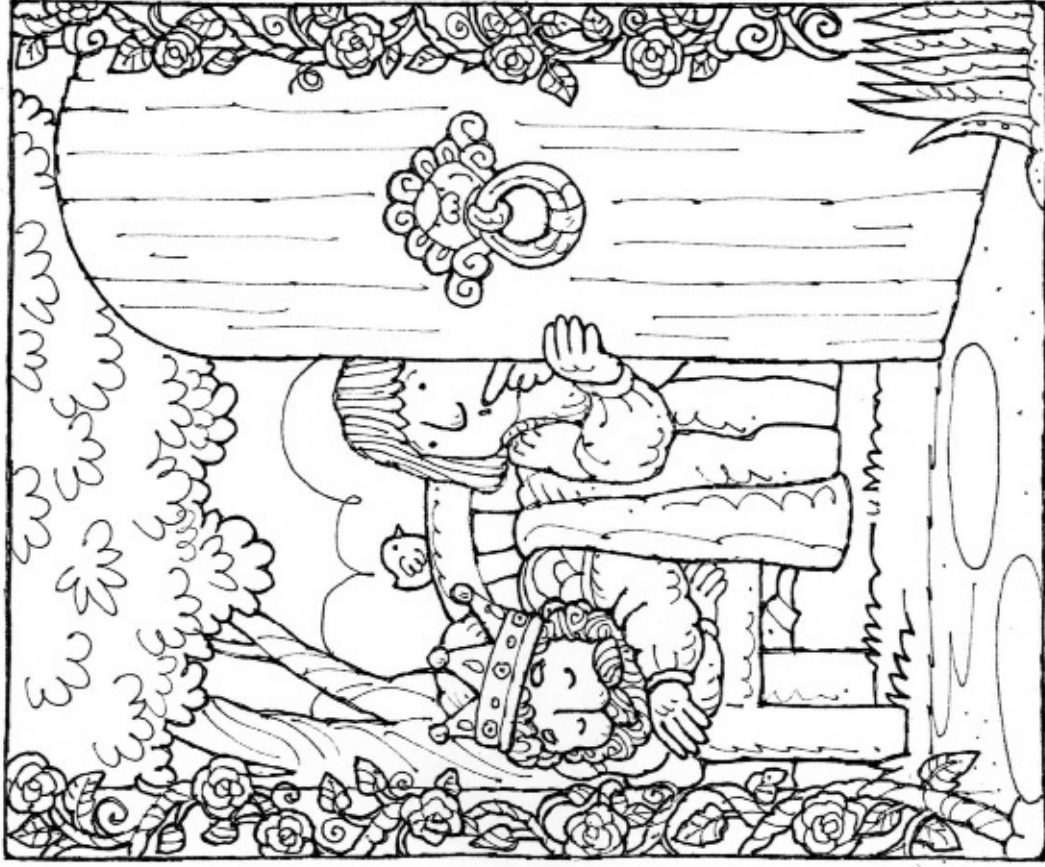

King Frank rested.  
He rested in the garden.





Sir Quint hushed the men.

"King Frank must rest."



Sir Quint ran to the garden.

Bang! Bang! Bang! Clank!

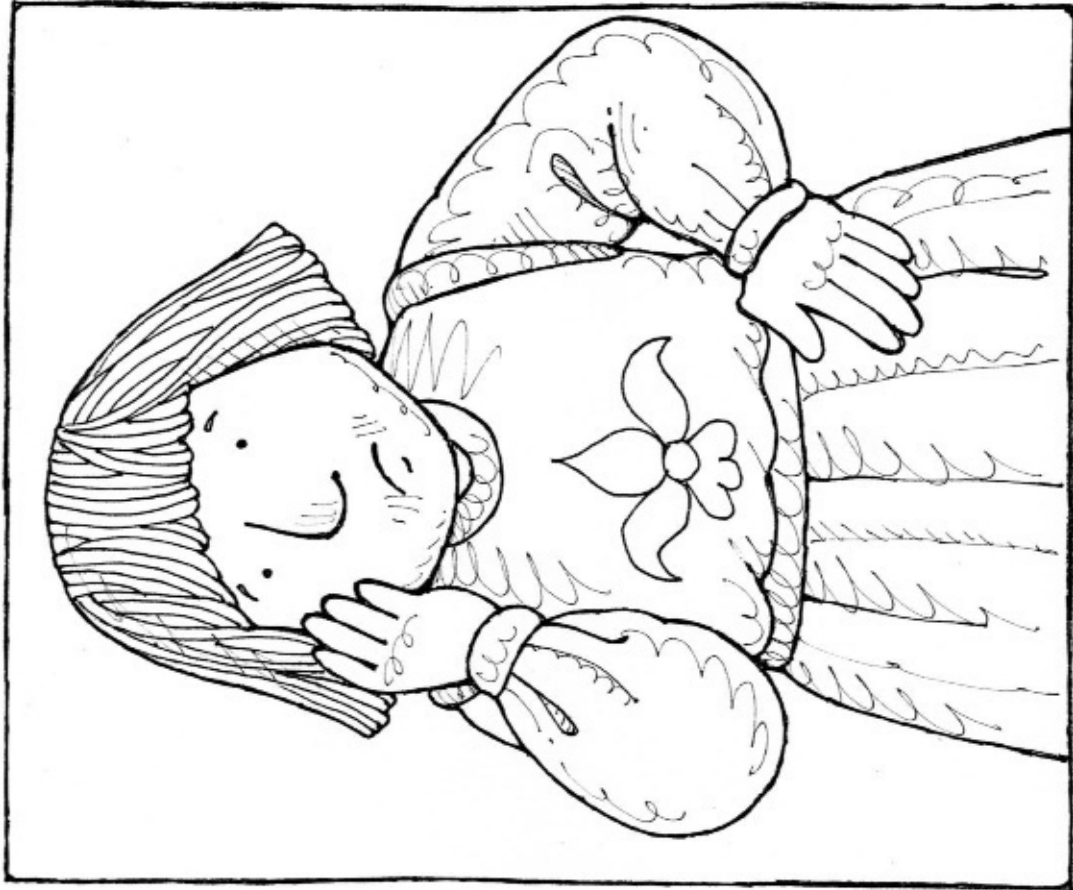

Sir Quint did a bit of quick thinking.

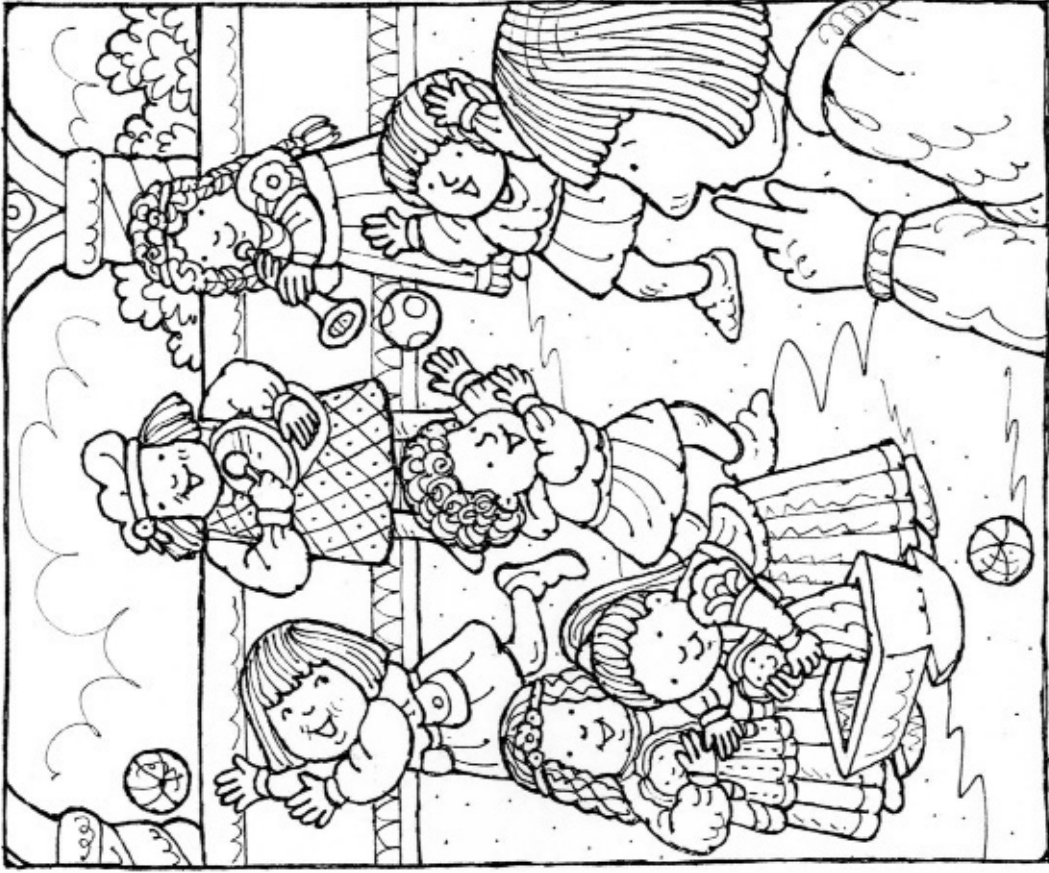

Sir Quint hushed the kids.

"King Frank is resting."



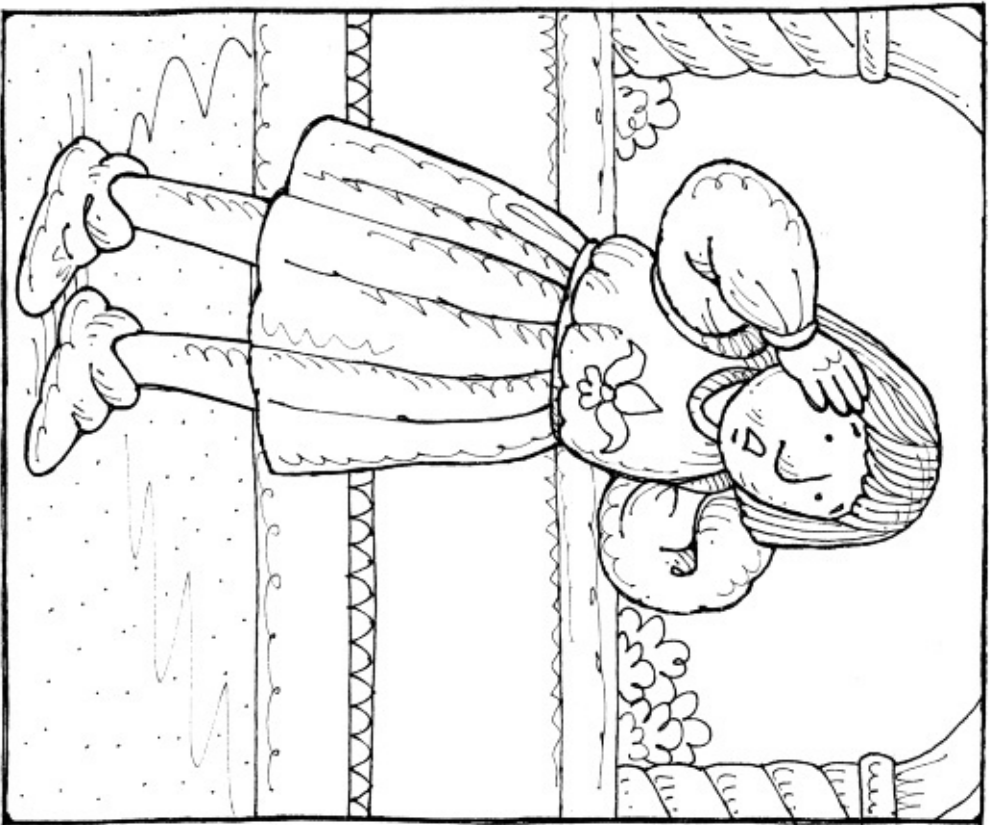

Then a problem happened.

Bang! Bang! Bang! Clank!

6

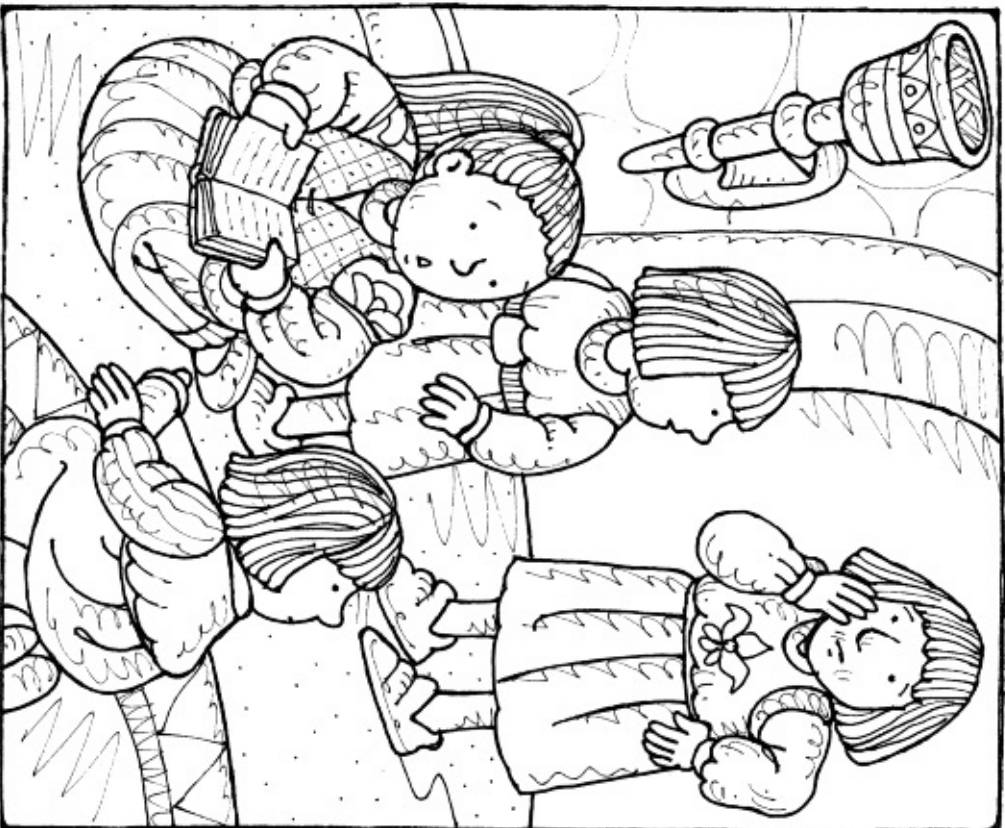

"Quit clanking!" said Sir Quint.

But the kids did not clank.

11



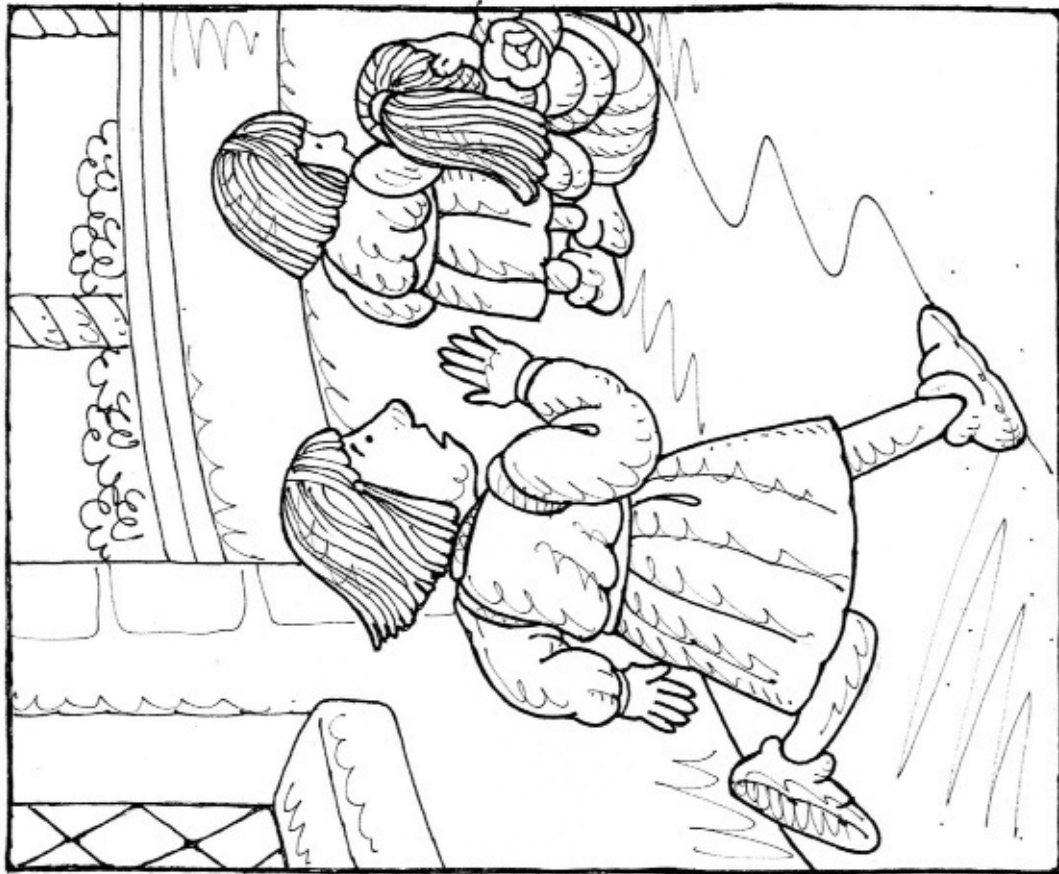

Bang! Bang! Bang! Clank!  
Sir Quint ran to the kids.

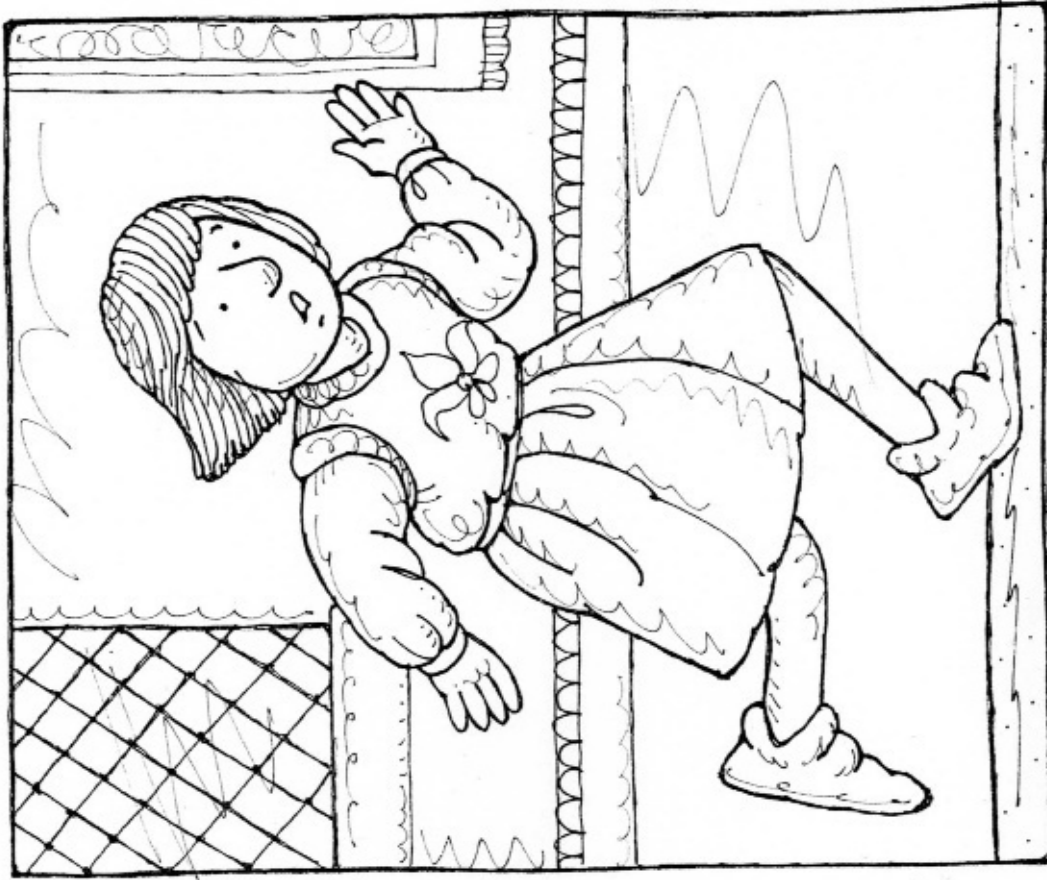

"What is that banging and clanking?"  
Sir Quint said, "That must stop this second!"



Bang! Bang! Bang! Clank!

Sir Quint ran to the men.



"Quit banging!" said Sir Quint.

But the men did not bang.

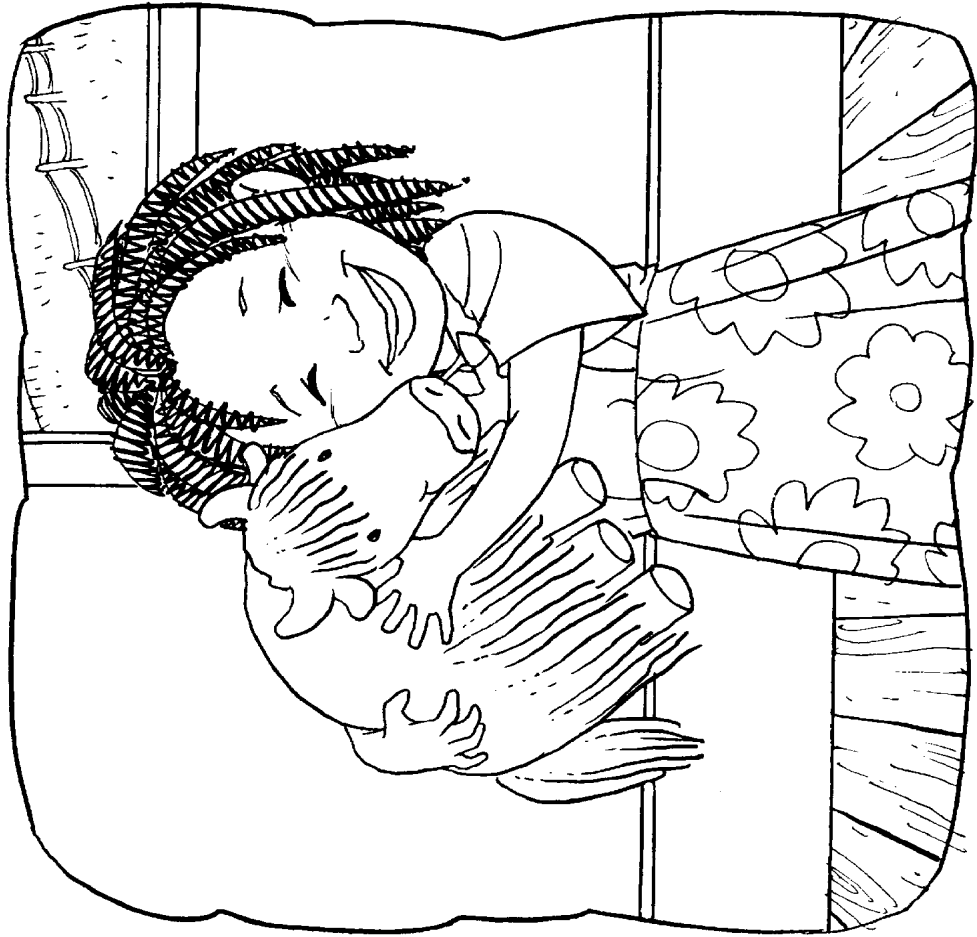

Is Beth's yak the best?

Beth thinks, "Yes!"

# Beth's Yak

by Betty Sanford  
illustrated by Shawn McManus

Core Decodable 59



Bothell, WA • Chicago, IL • Columbus, OH • New York, NY



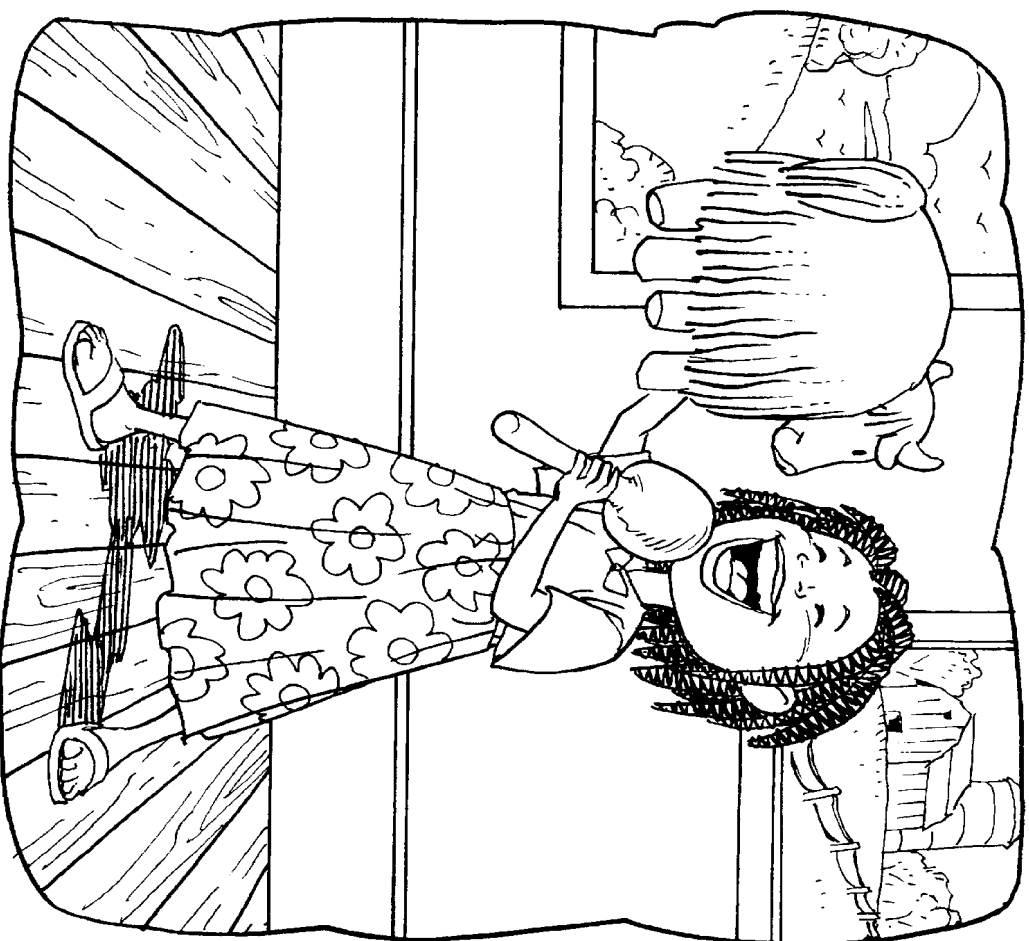

Beth sings to her yak.  
Beth will not yell at her yak.

MHEonline.com



Copyright © 2015 McGraw-Hill Education

All rights reserved. The contents, or parts thereof, may be reproduced in print form for non-profit educational use with *SRA Open Court Reading*, provided such reproductions bear copyright notice, but may not be reproduced in any form for any other purpose without the prior written consent of McGraw-Hill Education, including, but not limited to, network storage or transmission, or broadcast for distance learning.

Send all inquiries to:  
McGraw-Hill Education  
8787 Orion Place  
Columbus, OH 43240



Beth has a yarn craft for her yak.

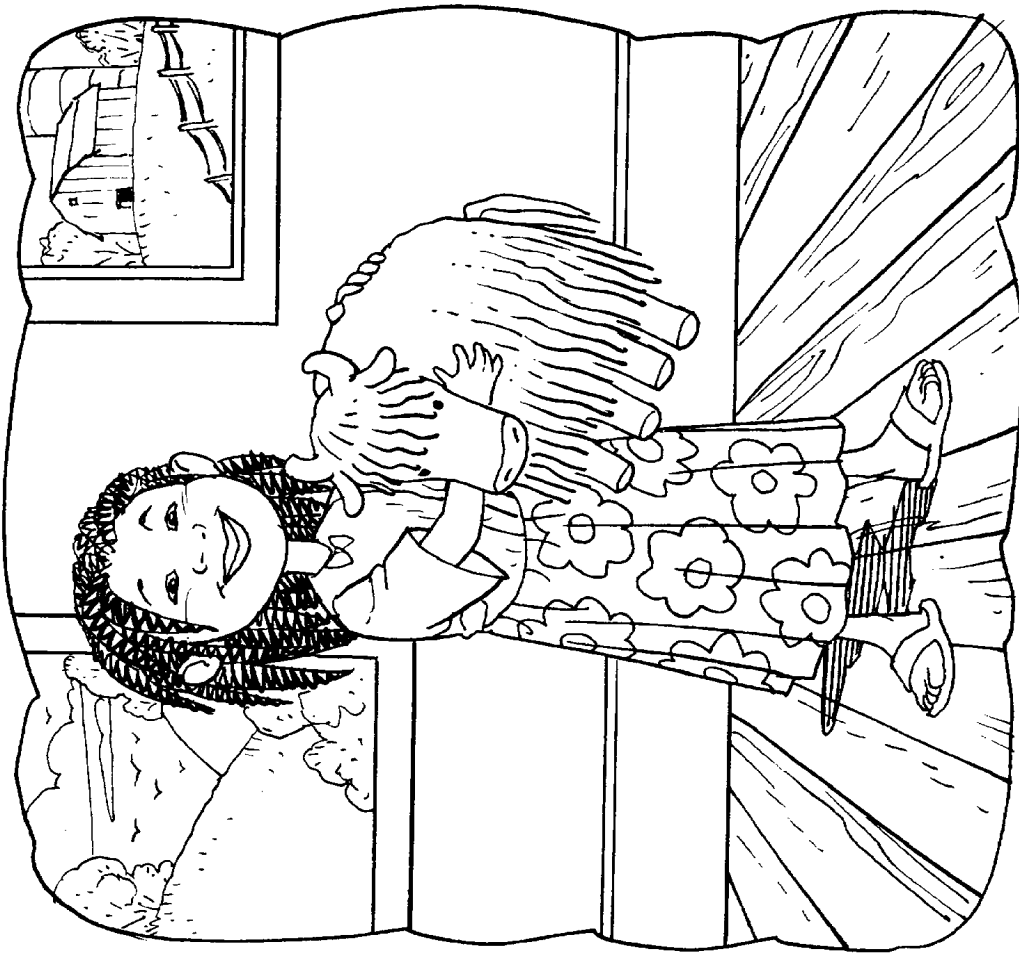

Beth had a big yak.

Beth kept her yak with her.





Beth kept her yak on her bed.

Beth kept her yak in her yard.

4

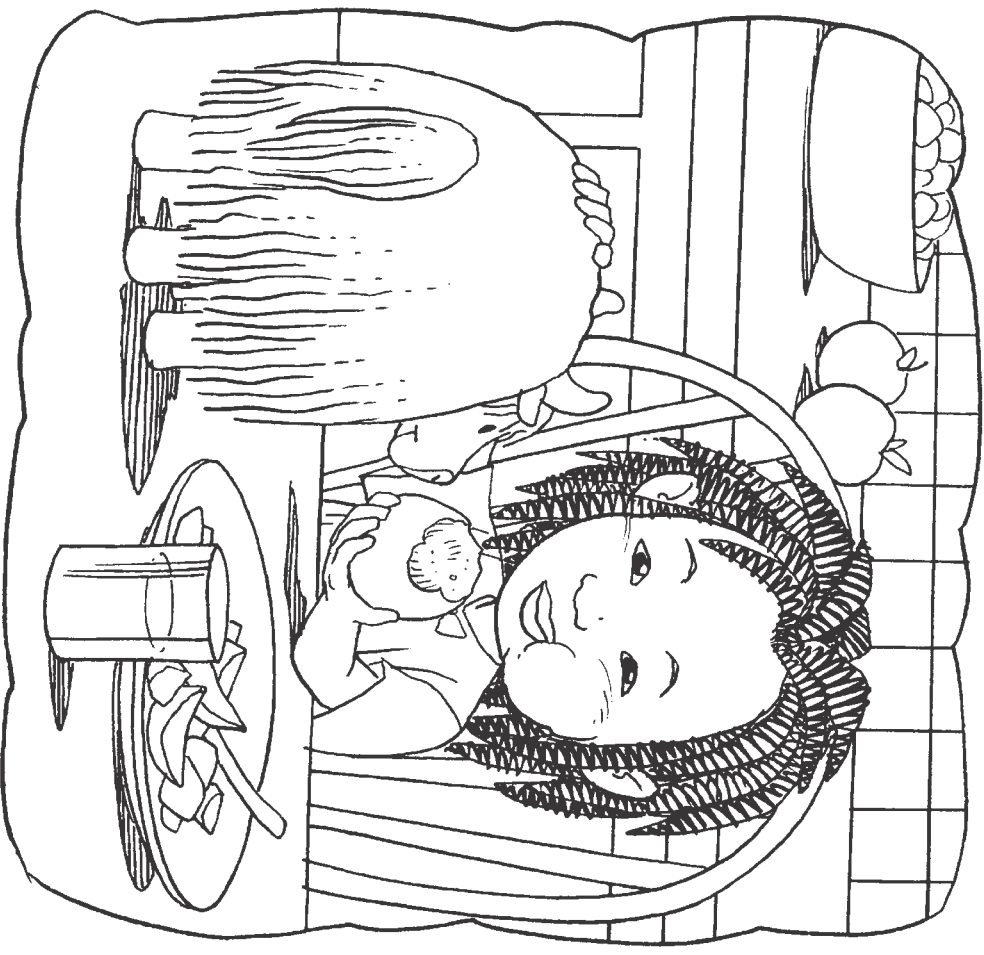

Beth fed her yak yams. Yum!

The yak did not like grass. Yuck!

5

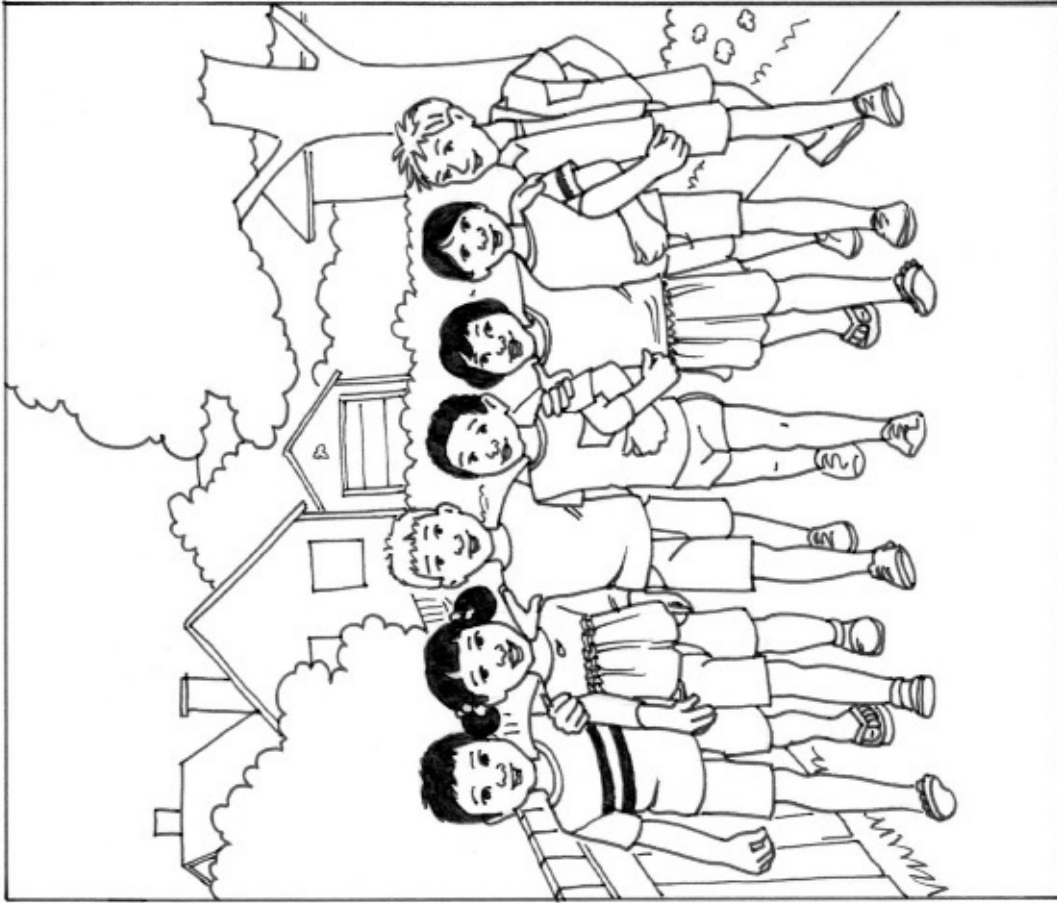

At ten, there were six best pals.

At eleven, there were seven!

# Seven Pals

by Greg Frazier  
illustrated by Jennifer Emery

Core Decodable 60



Bothell, WA • Chicago, IL • Columbus, OH • New York, NY

MHEonline.com



Copyright © 2015 McGraw-Hill Education

All rights reserved. The contents, or parts thereof, may be reproduced in print form for non-profit educational use with *SRA Open Court Reading*, provided such reproductions bear copyright notice, but may not be reproduced in any form for any other purpose without the prior written consent of McGraw-Hill Education, including, but not limited to, network storage or transmission, or broadcast for distance learning.

Send all inquiries to:  
McGraw-Hill Education  
8787 Orion Place  
Columbus, OH 43240

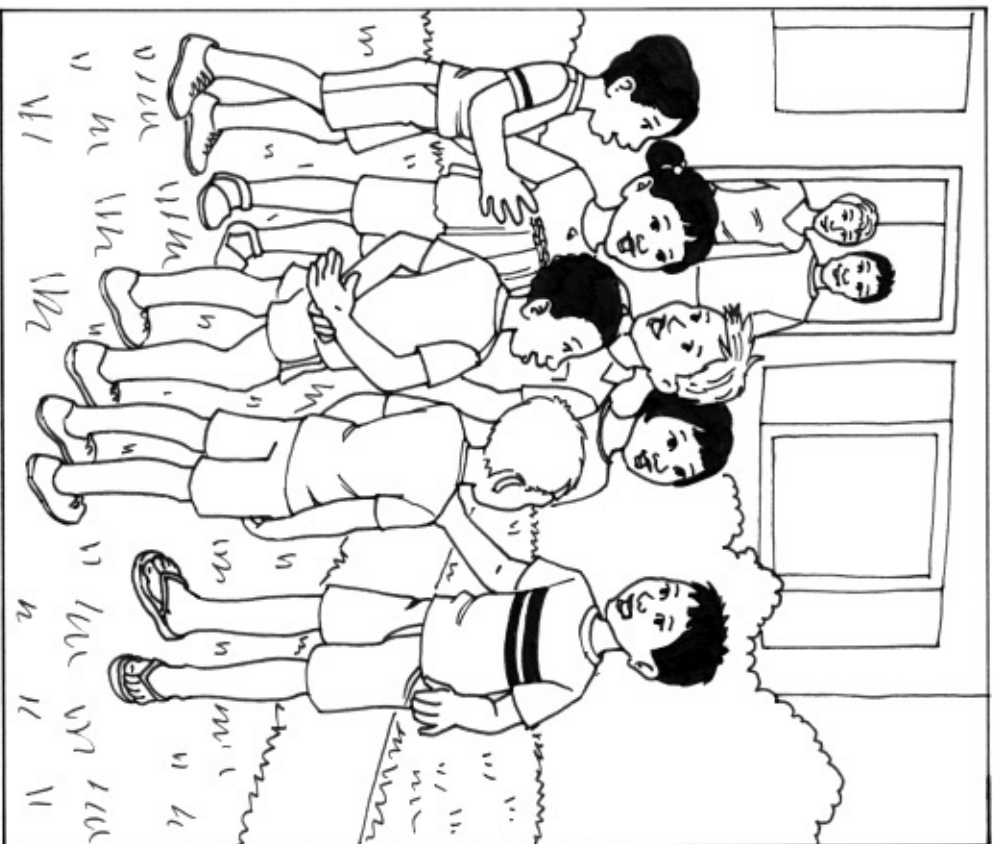

All six pals talked.  
Kevin talked.

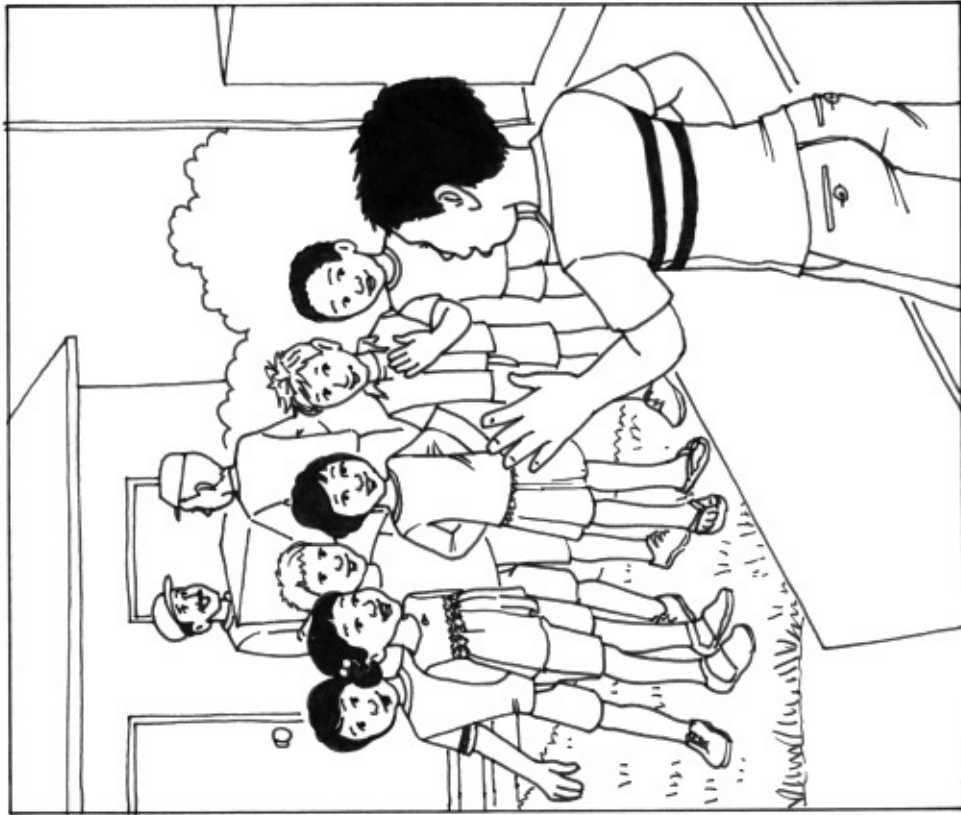

A kid was at the van.  
The pals had never met him.  
"I am Kevin," he said.

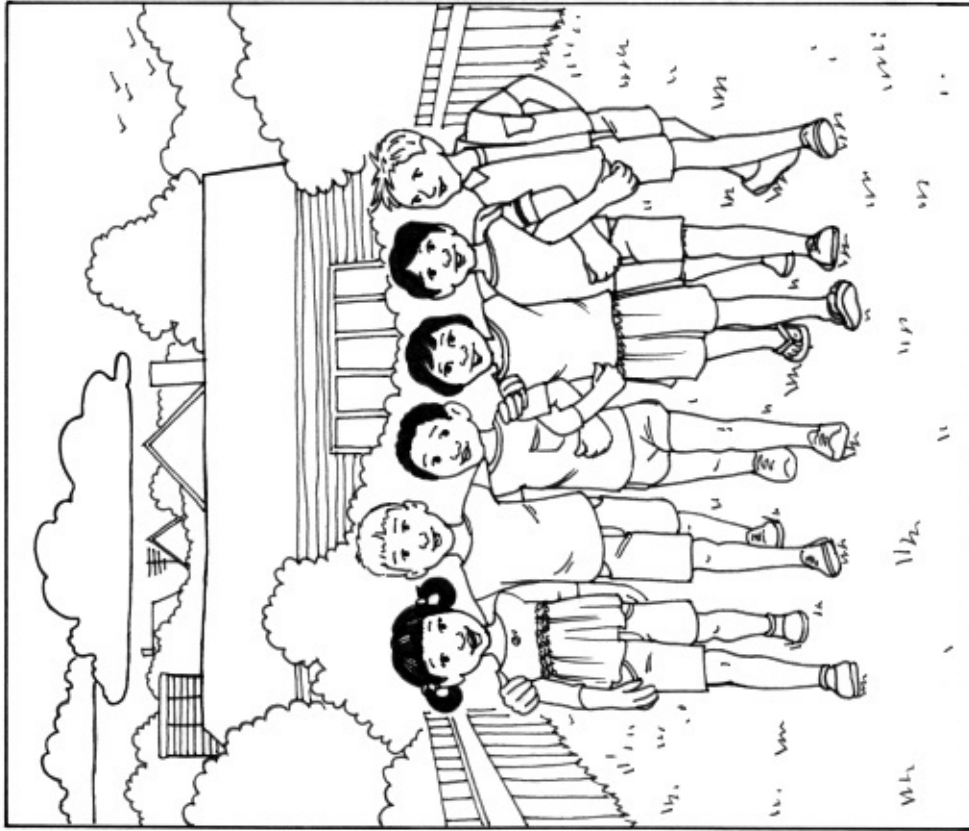

Six pals met at ten.  
All were best pals.



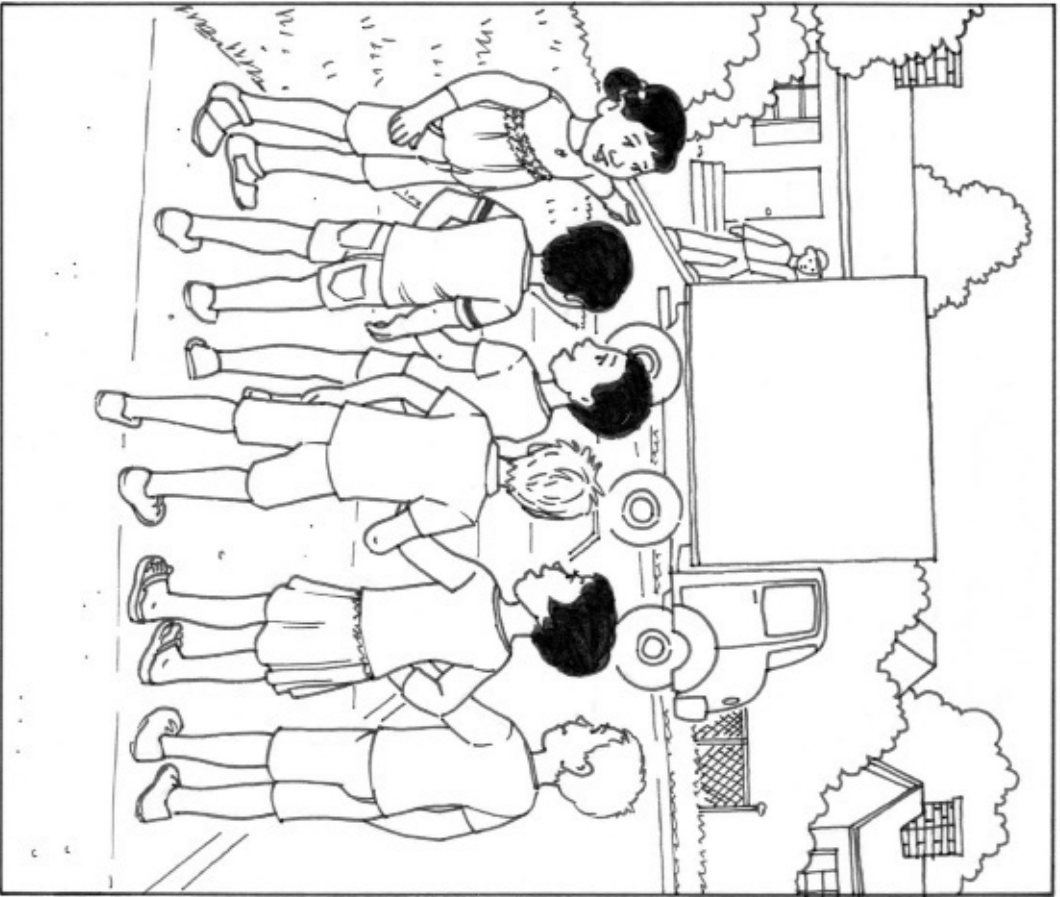

"A big van!" said Val.

All six pals spotted it.

4

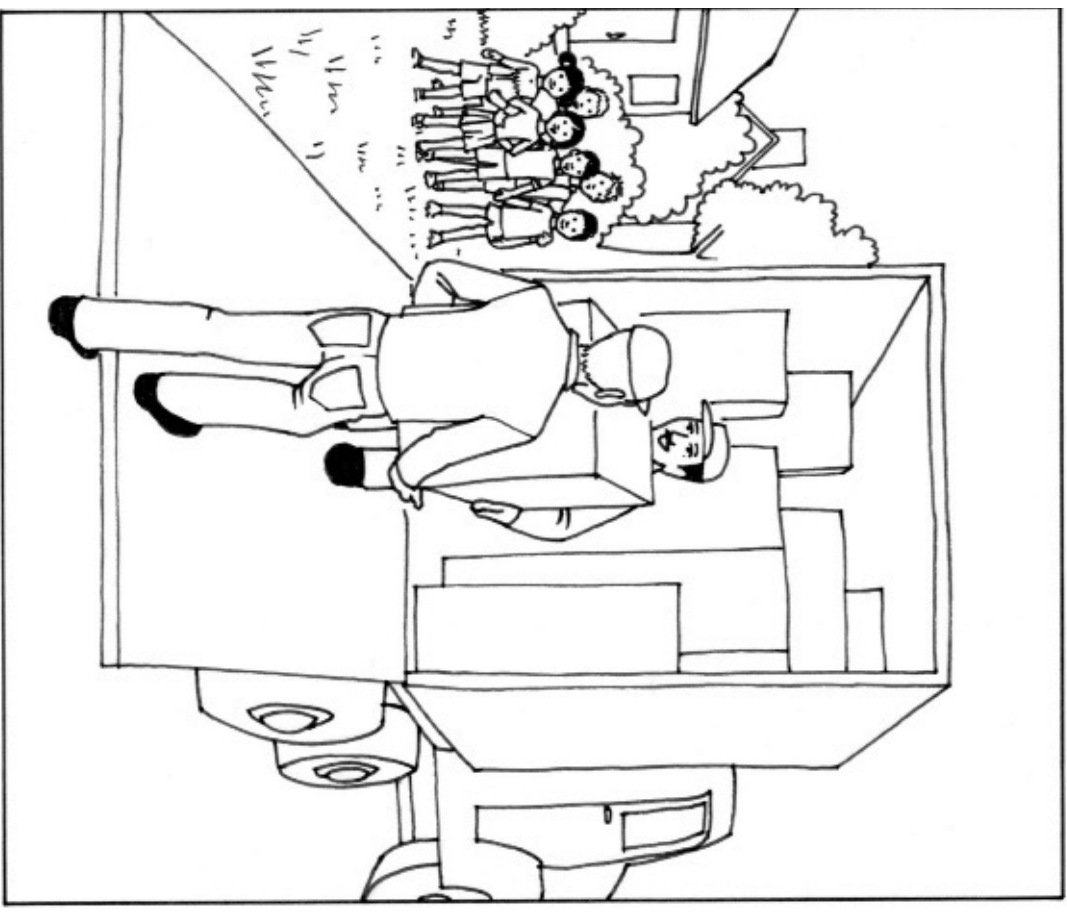

Men were on the van's ramp.

"Let's visit that van," said Vick.

5



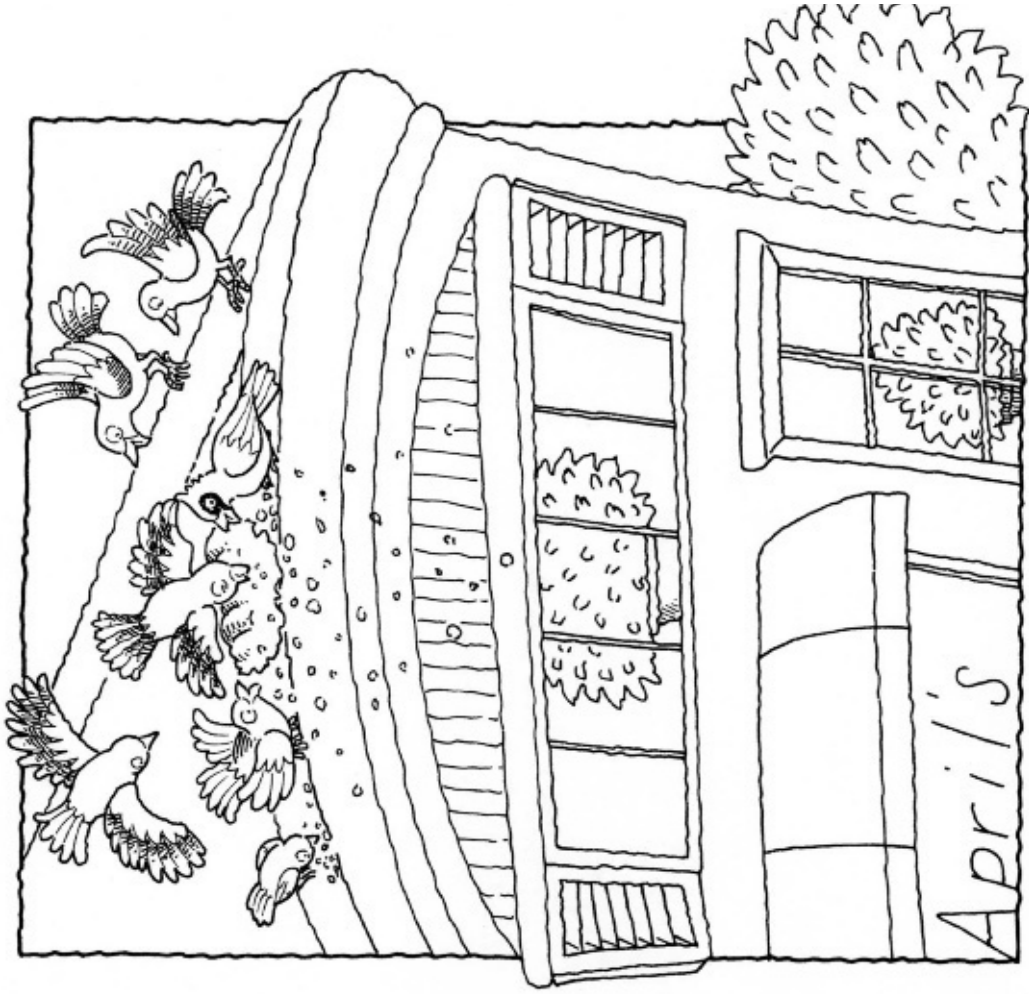

Birds sit on top of her shop.

Birds ate her bread!

# April's Bake Shop

by Lisa Boggs  
illustrated by Yvette Banek

Core Decodable 61



Bothell, WA • Chicago, IL • Columbus, OH • New York, NY

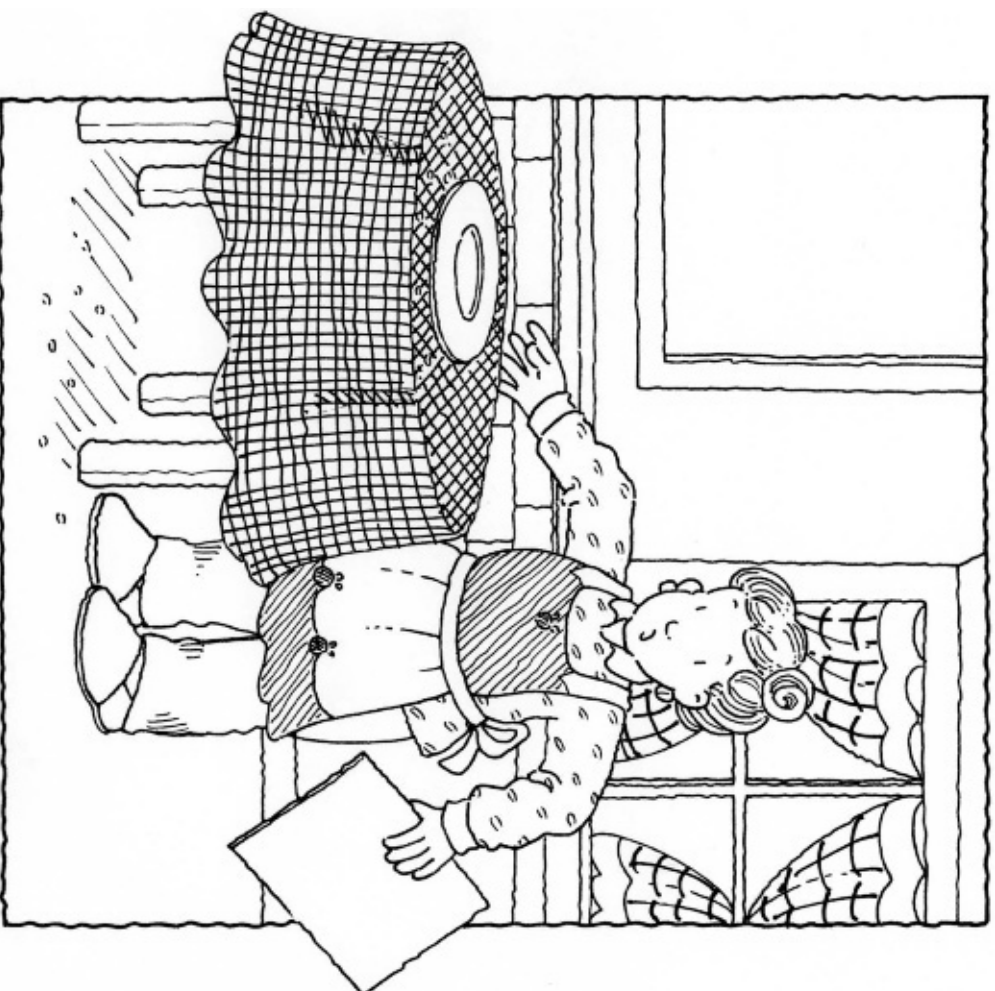

There is her table.

There is her plate.

What happened to her bread?

MHEonline.com



Copyright © 2015 McGraw-Hill Education

All rights reserved. The contents, or parts thereof, may be reproduced in print form for non-profit educational use with *SRA Open Court Reading*, provided such reproductions bear copyright notice, but may not be reproduced in any form for any other purpose without the prior written consent of McGraw-Hill Education, including, but not limited to, network storage or transmission, or broadcast for distance learning.

Send all inquiries to:  
McGraw-Hill Education  
8787 Orion Place  
Columbus, OH 43240

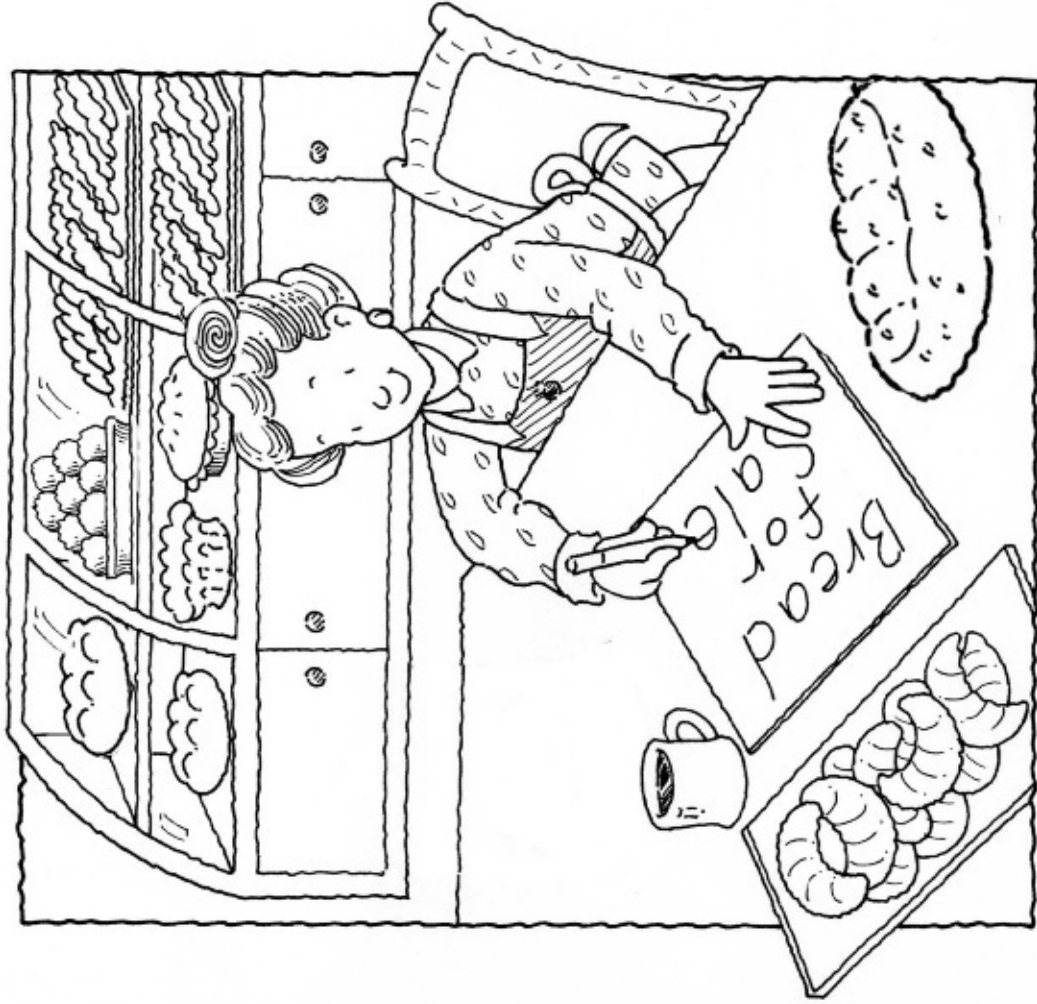

April prints a paper label.  
She makes "Bread for Sale."

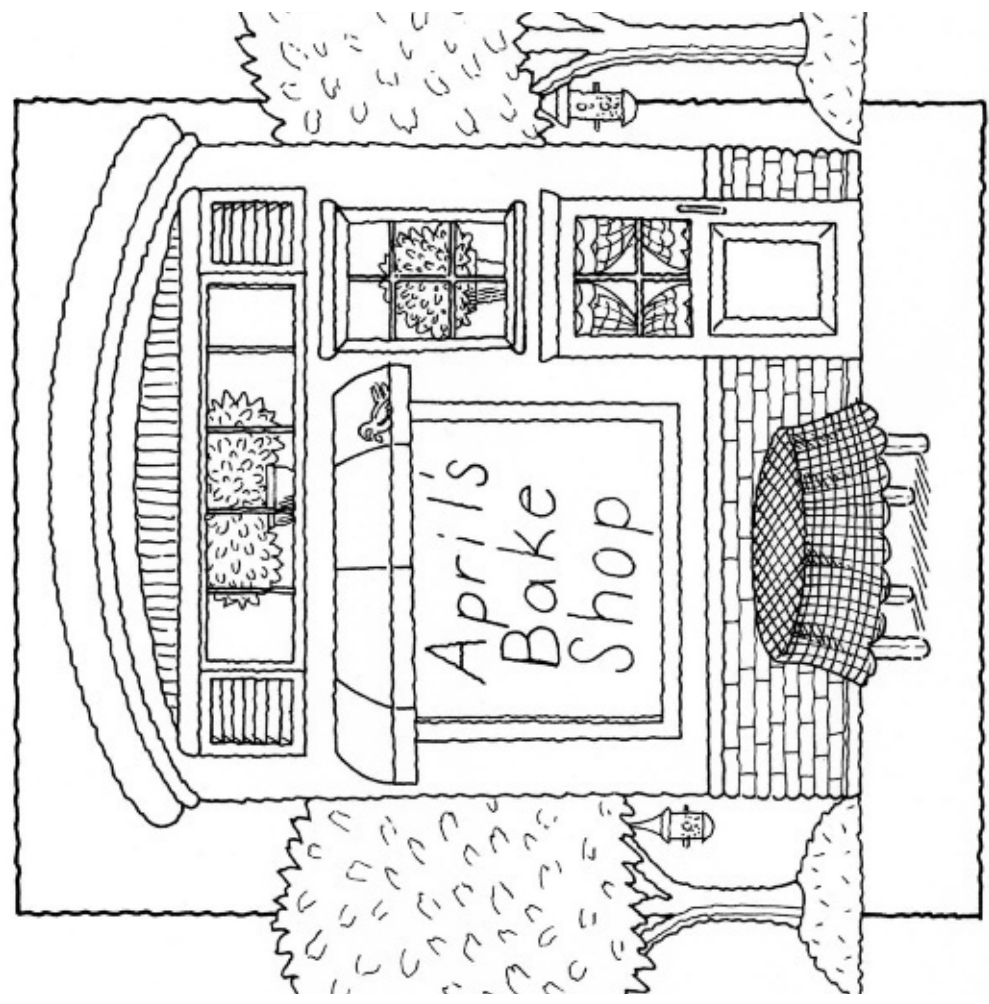

Down the block is a shop.  
It's April's Bake Shop.



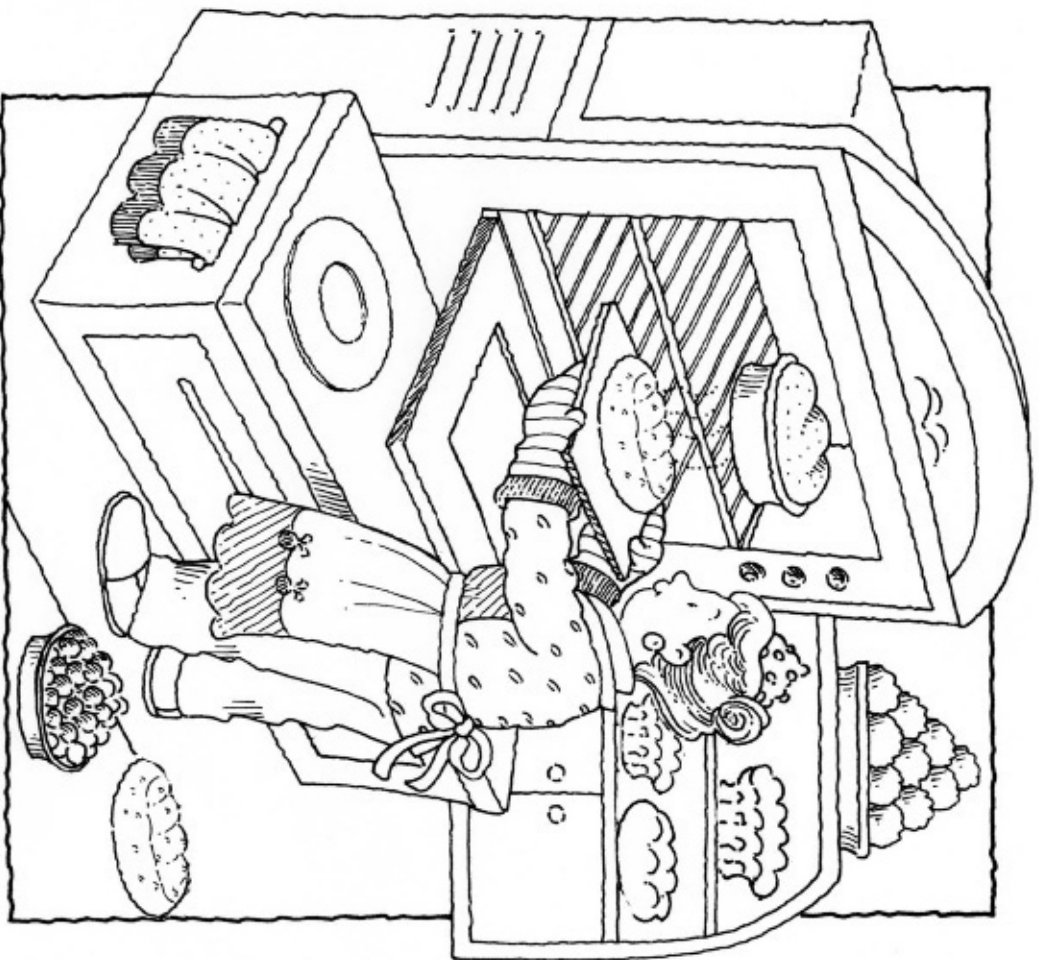

April bakes bread.

She sets it on a plate.

4

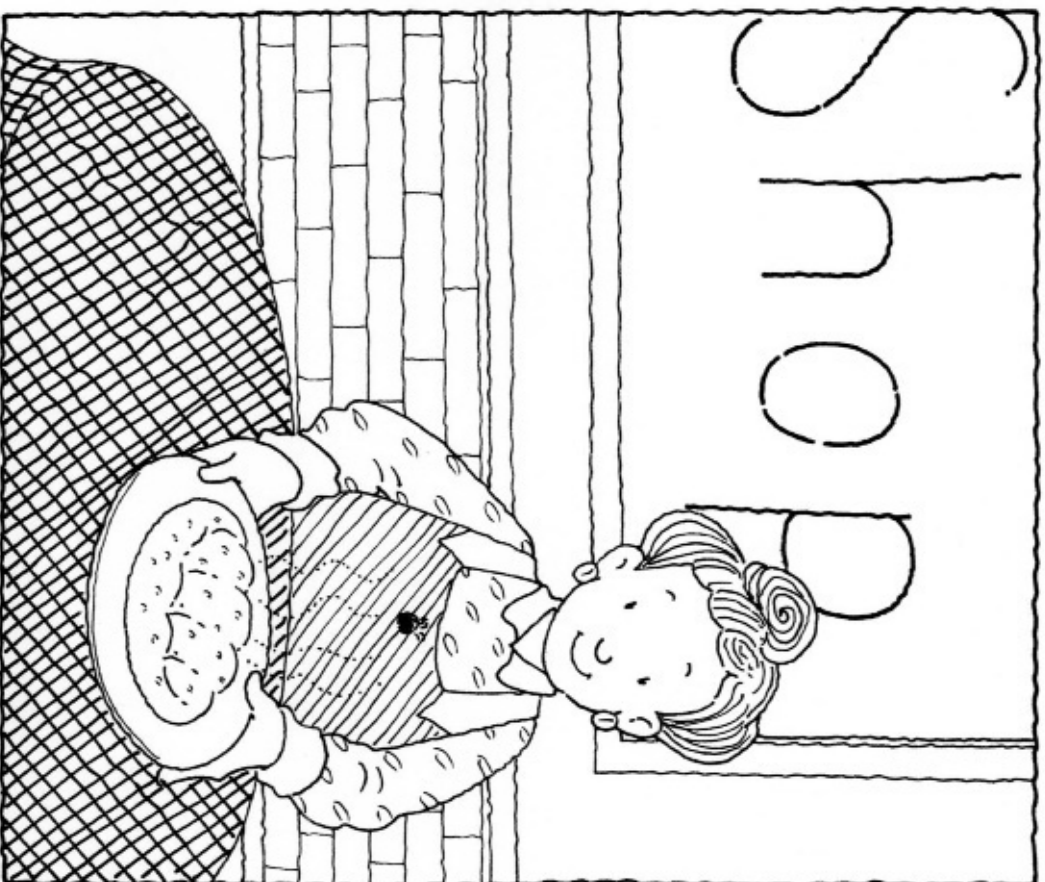

She takes her plate out.

She sets it on a table.

5

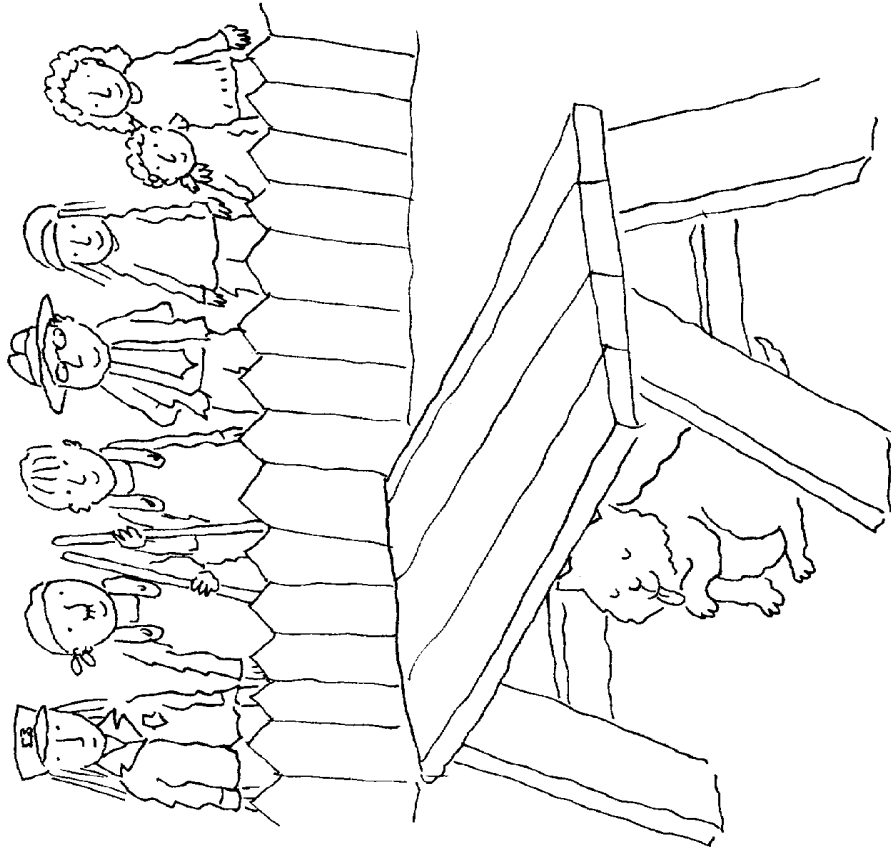

“Tab is back,” said Barb.

“Tab is safe under the table.”

# Tab

by Ethan Cruz  
illustrated by Paige Keiser

Core Decodable 62



Bothell, WA • Chicago, IL • Columbus, OH • New York, NY



MHEonline.com



Copyright © 2015 McGraw-Hill Education

All rights reserved. The contents, or parts thereof, may be reproduced in print form for non-profit educational use with *SRA Open Court Reading*, provided such reproductions bear copyright notice, but may not be reproduced in any form for any other purpose without the prior written consent of McGraw-Hill Education, including, but not limited to, network storage or transmission, or broadcast for distance learning.

Send all inquiries to:  
McGraw-Hill Education  
8787 Orion Place  
Columbus, OH 43240

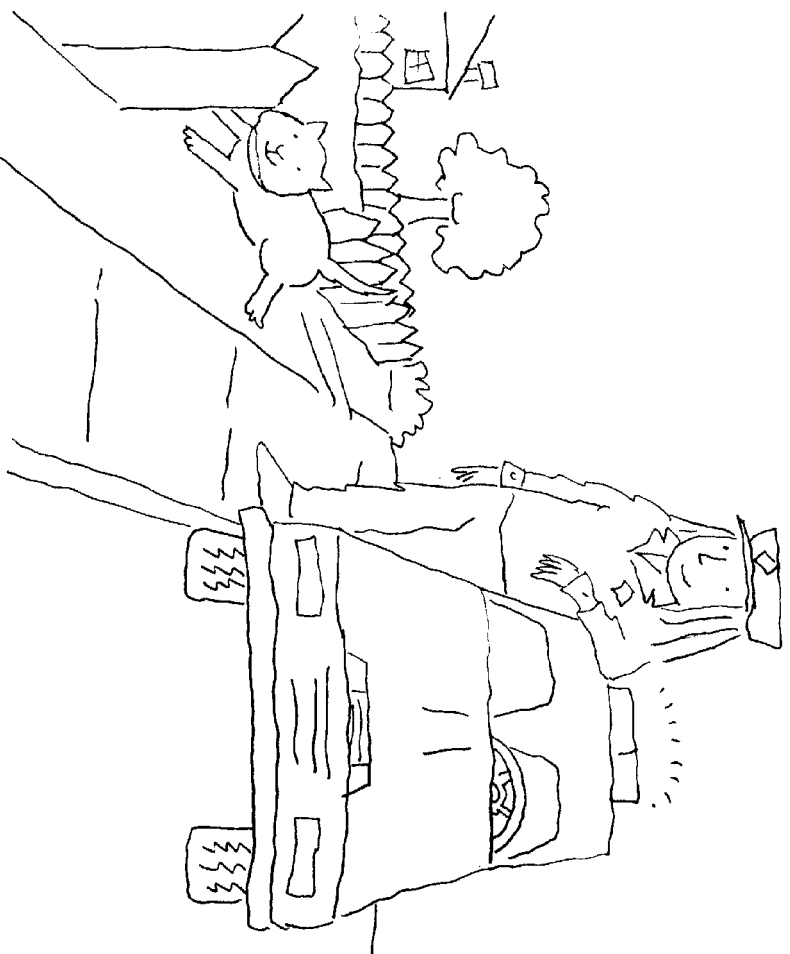

Barb spotted the chase a little later.  
She chuckled and checked on Tab.

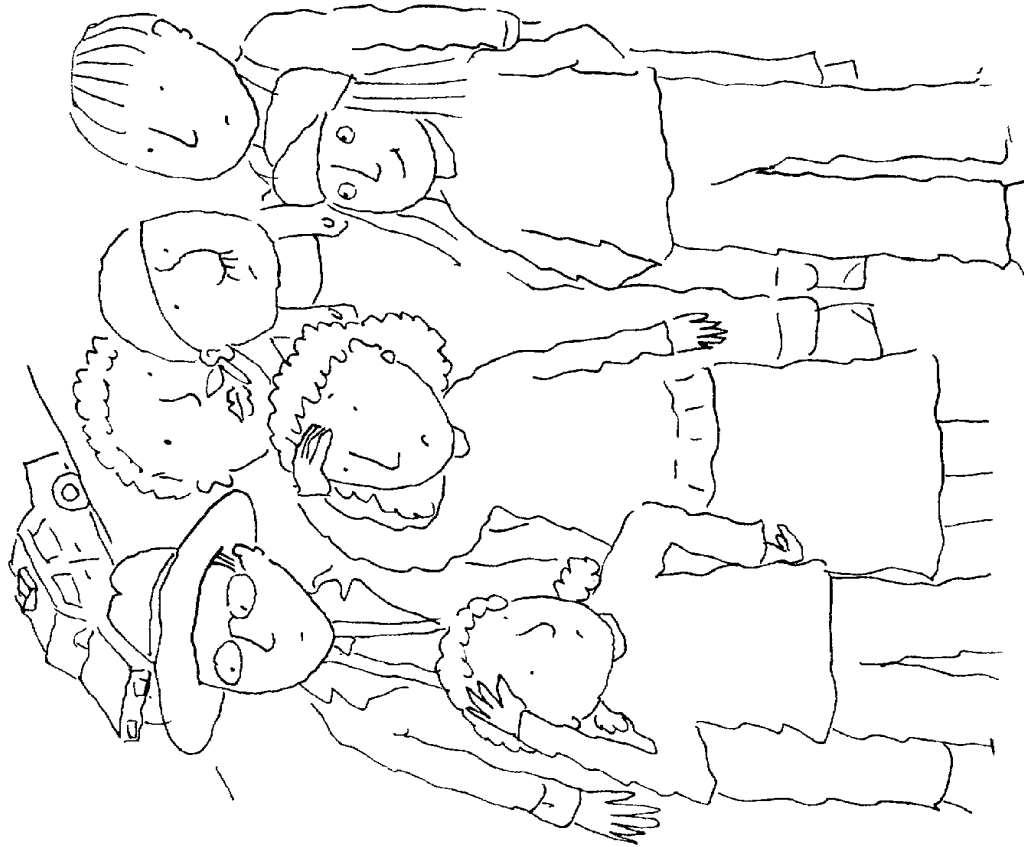

“This is a puzzle,” said Jane.

“I cannot see Tab.”

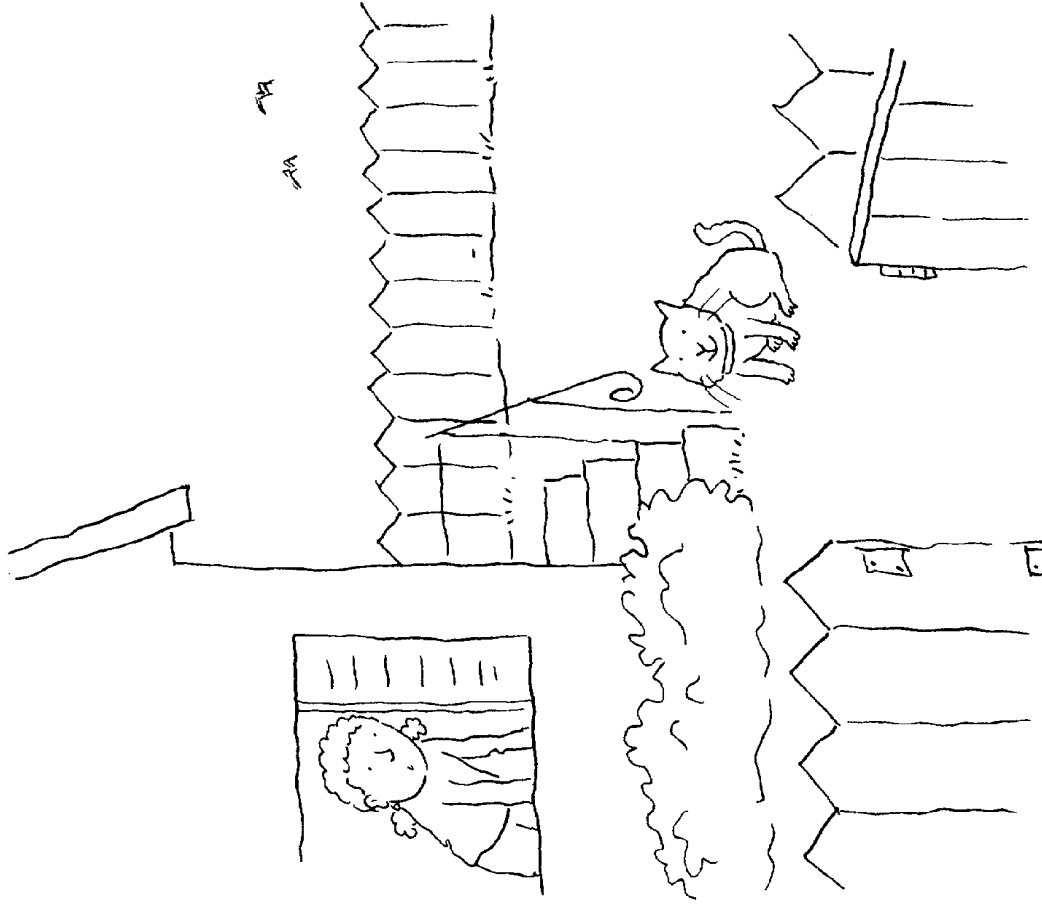

Did the back gate shut?  
Jane looked at the handle.

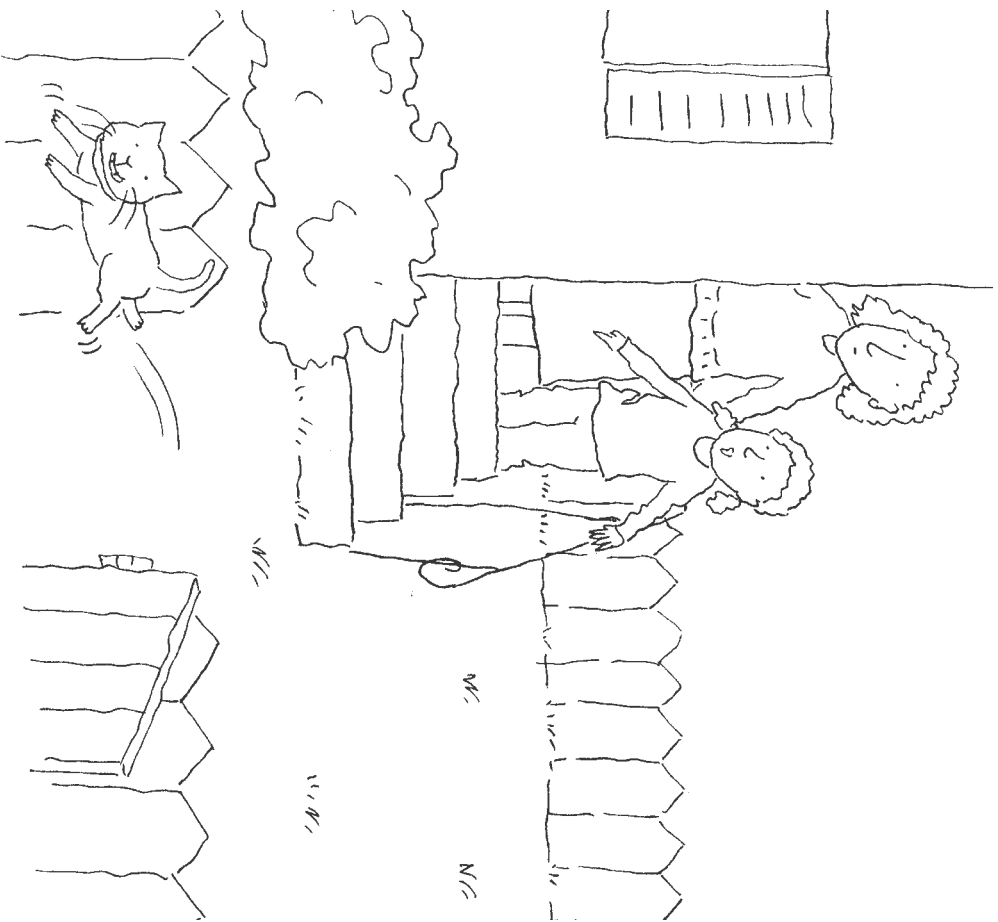

The gate did not shut.

Jane's kitten, Tab, left the yard.

4



Tab made a quick turn.

Jane did not see her.

13



“Stop, Tab!”

Kate and Jason yelled and helped.

Val and the men yelled and helped.

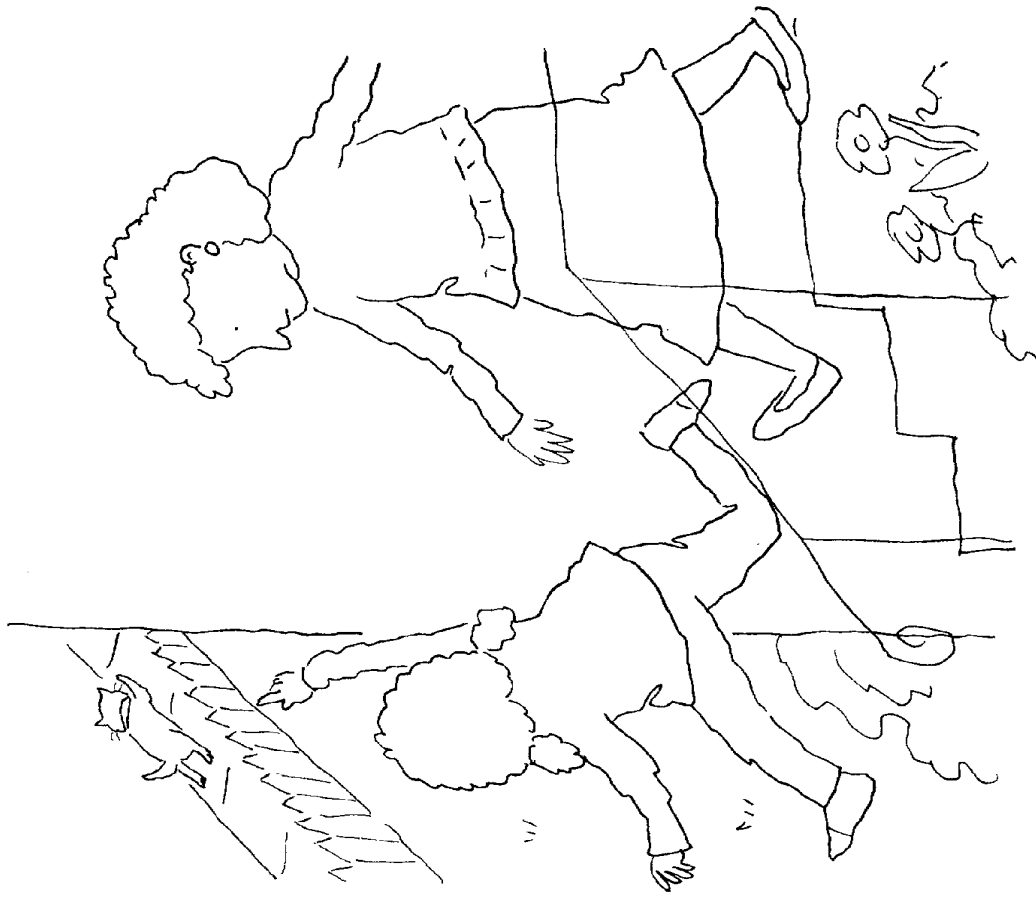

Did Tab run fast?

Yes, quick Tab ran down Apple Lane.

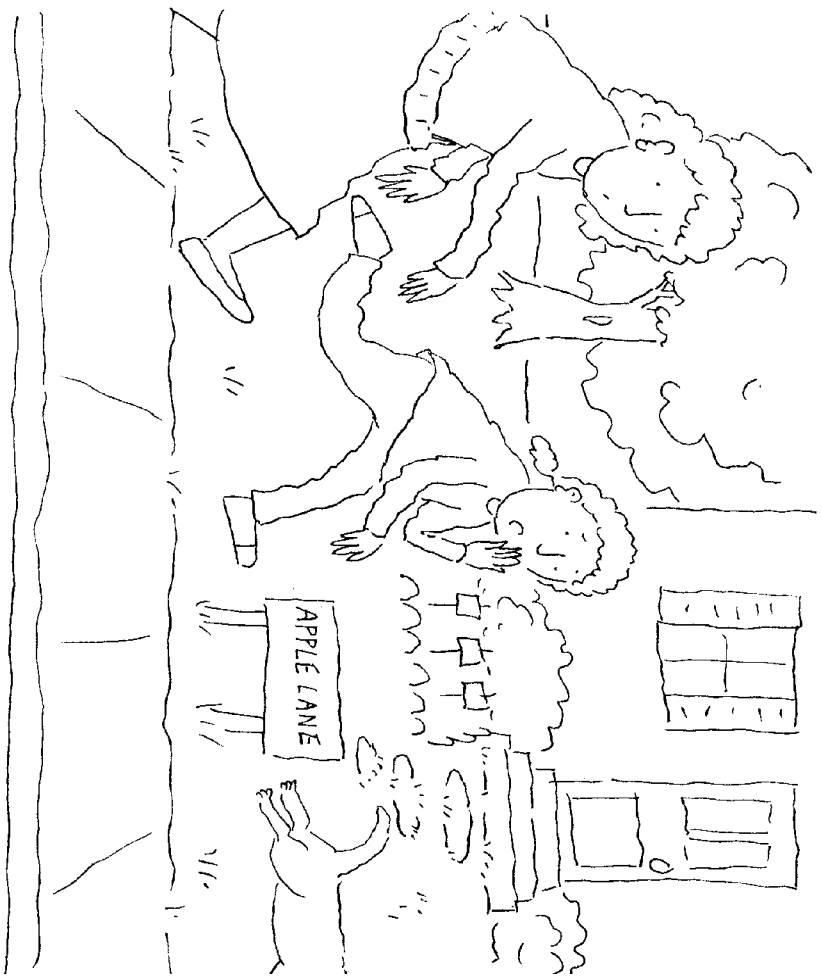

Jane had to chase her kitten.

"Stop, Tabi!" she yelled.

6

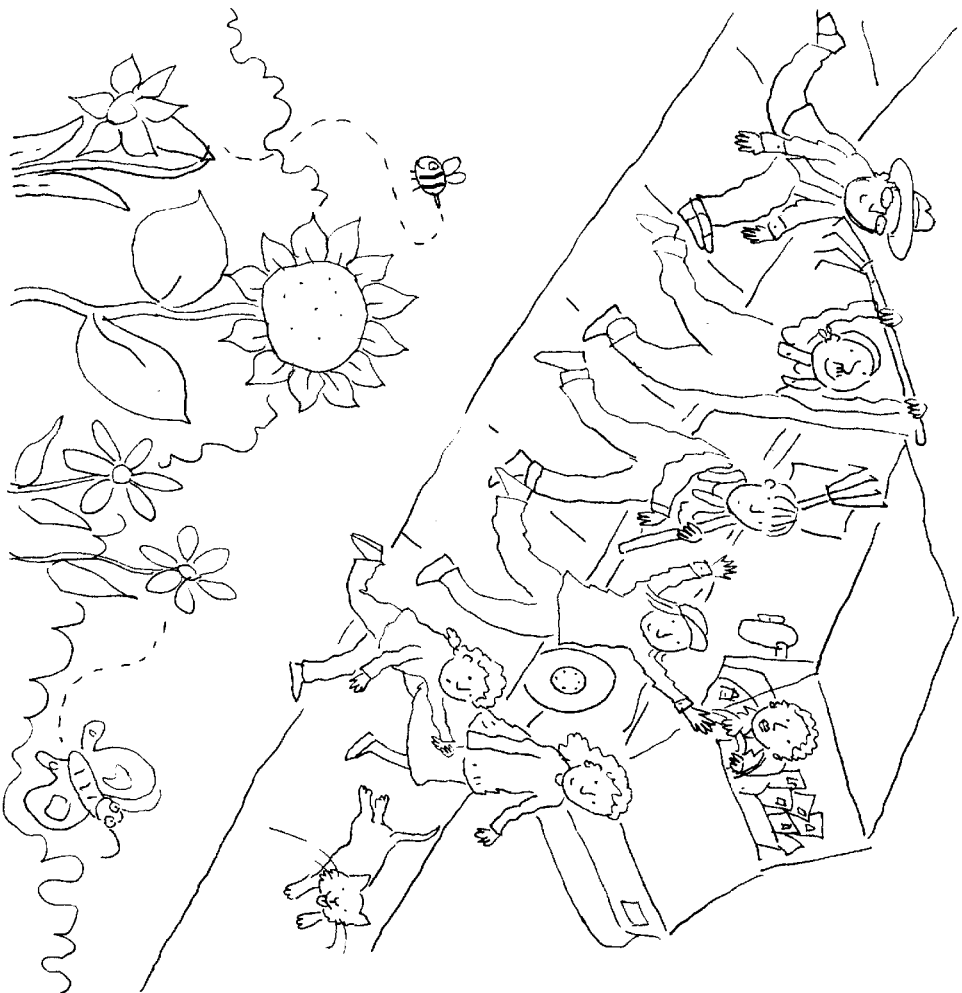

Val was in her van.

"I will help," she yelled.

11





Little Tab ran and ran.  
This game of chase was fun.

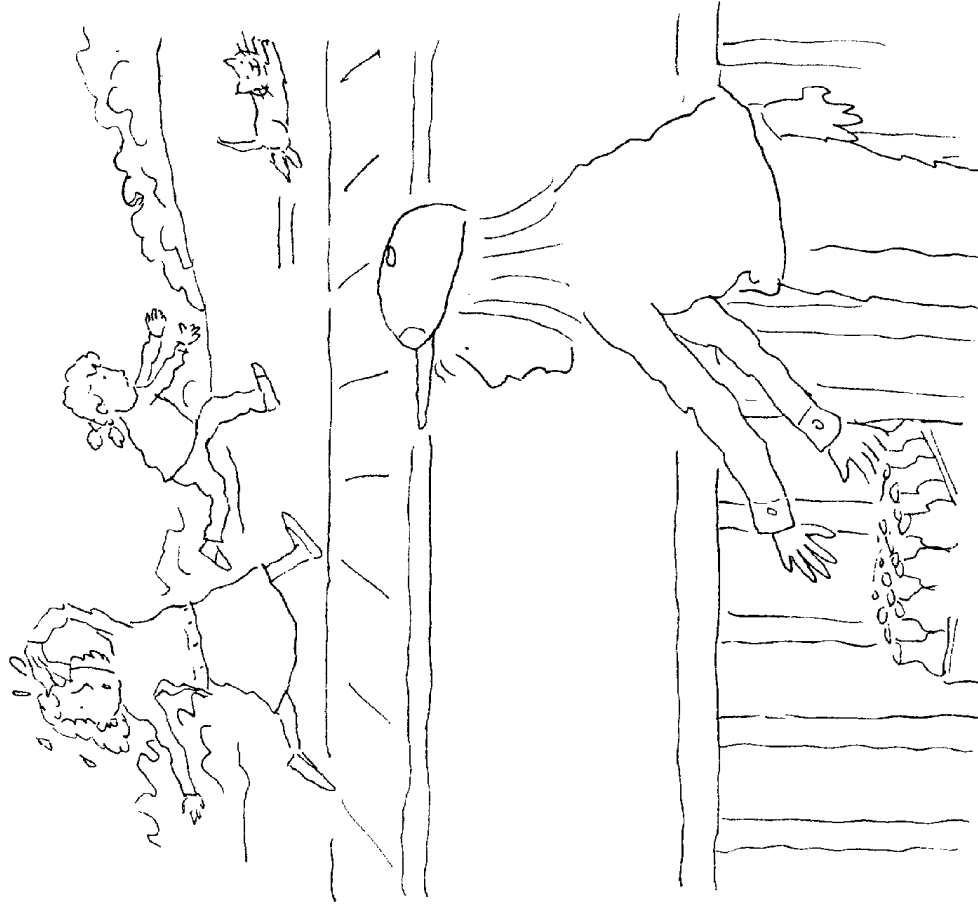

Kate set down her bottles.  
“I will help,” she said.



Tab ran past men with rakes.

The men helped and yelled, "Stop, Tabbi!"

8

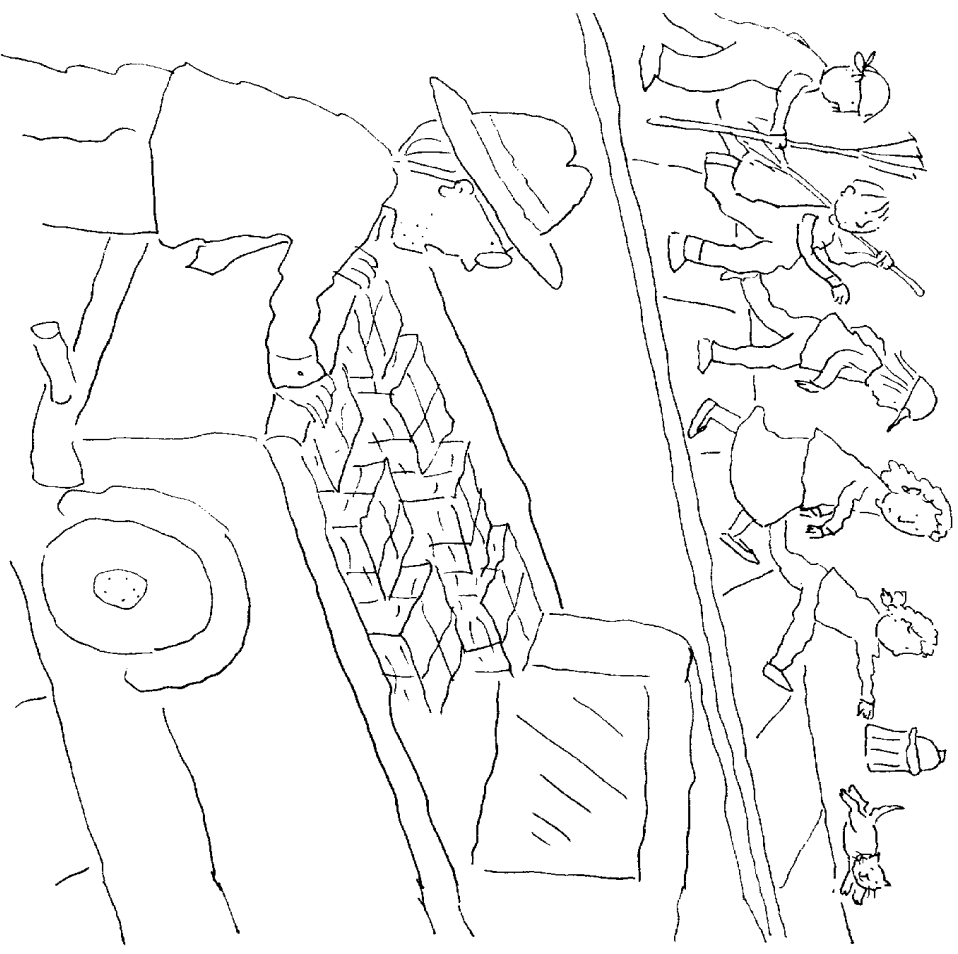

Jason had seven bundles of paper.

"I can help!" he yelled.

9